

2020

2020

AIR CONDITIONERS



LG HVAC SOLUTION

# AIR CONDITIONERS



LG Electronics

<http://www.lg.com>  
<http://partner.lge.com>

Distributed by



# EUROPE SALES INFRASTRUCTURE

-  Europe B2B Regional Head Office
-  National Sales Office
-  Air Conditioning Academy
-  European Distribution Center
-  Europe Energy Lab
-  Production Site

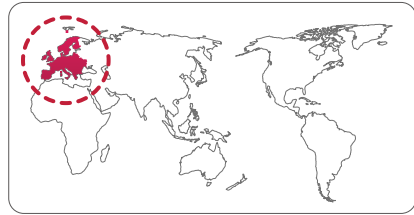

# GLOBAL PRODUCTION SITE



## LG Energy Labs in Europe

LG Energy Labs are driven to fulfill the commitment of meeting all the requirements regarding energy efficiency and environmental demands. Each LG Energy Lab is an innovative site dedicated to provide essential commercial and residential products in heating, ventilation and the latest energy efficient air conditioning solutions. Additionally, as a showcase, the LG Energy Lab is equipped with complete monitoring and control systems. The performance of all products are tracked and analyzed by a team of Research and Development engineers based in France, Finland and Korea, ensuring maximum efficiency and reliability during the complete products' lifecycle.



## European Air Conditioning Distribution Center

LG's European Air Conditioning Distribution Center is centralised in Oosterhout, the Netherlands. Supplying and delivering products to 15 countries in Europe, this Distribution hub has contributed to quick and seamless delivery, direct shipping for smaller orders and bespoke delivery to air conditioners. The hub tries to manage inventory efficiency by complying with the LG EU's established inventory pool.

# TOTAL HVAC SOLUTION PROVIDER

Since manufacturing Korea's first air conditioner exclusively designed for residential use in 1968, LG has been a pioneer of air conditioning innovation. Encouraged by LG's technological leadership in the residential air conditioning sector since the late 1990s, LG moved into the commercial air conditioning sector.

LG has established itself as an exemplary HVAC and energy solutions provider, investing in new technologies, with the addition of chiller, VRF systems and building management systems (BMS) to its comprehensive product portfolio. Alongside its wide range of innovative solutions, the LG promise is to deliver unparalleled customer service.

LG produces expert air conditioning professionals at its academic centers, of which there are nearly 80 worldwide. These academic centers provide workshops and training programs that offer excellent hands-on experience. Additionally, LG provides advanced and highly sophisticated tools for HVAC system engineers and installers, including its time saving LG Air Conditioner Technical Solution (LATS) software. LATS allows LG to support clients with draft energy estimation and energy modeling, model selection and design, lifecycle cost analysis and more to ensure a seamless process from planning to execution. LG also operates several state-of-the-art R&D facilities all across the planet.

# Made Better with LG ThinQ™

With most people living lives that are more hectic than ever before, we see the enormous potential benefits new technologies will bring to the home. LG ThinQ links smart products together so that they can work in unison to make your home smarter and more connected. New levels of control and convenience simplify everyday life and free up time so that you can stay focused on what matters. Furthermore, transformative features and services with artificial intelligence will take home evolution one step further. LG ThinQ will provide more personalized and optimized solutions by learning your needs and preferences through its wide range of products. Get more done while doing less. LG ThinQ's Personalized Solution, Proactive Advice, Maximum Efficiency and Intuitive Control deliver an elevated, more intelligent lifestyle. LG ensures its intelligent offerings, AI-powered products and services unlock new roles for homes that can play an important role for truly smart living. Think Wise. Be Free.

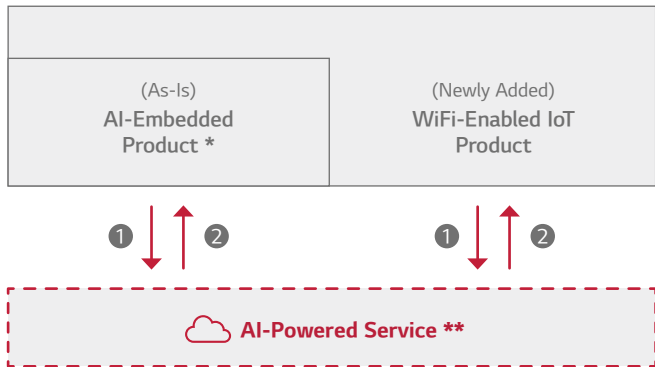

- 1 Understanding users via data collection
- 2 Providing tips & solutions through AI data analytics

\* Previous LG ThinQ products-Requirement: evolving products with vocal/visual/product intelligence  
 \*\* Examples of AI-Powered Service: -Usage guide/tips, Predictive maintenance, Auto/semi-auto setting (TBD)

## Consumer Benefits

**Intuitive Control**  
 LG ThinQ adds convenience to your daily life by simplifying daily tasks. The LG ThinQ experience is reliable, flexible and effortless from setup to control -and beyond. LG ThinQ products can be controlled from anywhere and at any time with simple voice-commands and a tap of the innovative ThinQ smartphone application. Meaning anywhere can be your home.

**Maximum Efficiency**  
 LG ThinQ minimizes energy consumption and can even track your energy usage and expenditure. Beyond mechanical advancements, LG ThinQ provides unrivaled energy efficiency by utilizing a combination of analytics, sensors and usage data.

**Personalized Solution**  
 LG ThinQ provides tailored recommendations and optimal settings, with your needs and preferences taken into account. Thanks to the power of AI, the same products can offer different experiences depending on your unique tastes and specific situations.

“  
**LG ThinQ :**  
**A Brand for Products and**  
**Services Incorporating**  
**Advanced AI Technologies**  
 ”





134 - 249  
**COMMERCIAL**

SINGLE SPLIT 138



008 - 133  
**RESIDENTIAL**

WALL MOUNTED 016  
MULTI SPLIT 072



# RESIDENTIAL

WALL MOUNTED

MULTI SPLIT



Anytime, Anywhere!

# DUAL COOL ThinQ™

with Voice Control



OK Google, turn on the air conditioner.

Sure, turning on



## Key Feature

### Enhance your daily life with LG ThinQ

**Cool home when you arrive**  
"It would be wonderful if my place is already cool when I arrive."

**Check electricity bills throughout the month**  
"How much have I been using the AC lately?"

**Switch off AC after you've left**  
"Oh no! Did I remember to turn off the AC?"

**No need to search for the remote control your AC with your phone**  
"Where's the remote control? I don't want to move a inch from my bed!"

### Simple voice control, time saving & accessible to everyone

No need to wander around searching for your AC's remote control. LG DUALCOOL LG ThinQ models are also compatible with AI speakers such as LG ThinQ with Google Assistant, Alexa, Google Home and more. From now on, don't bother pressing any buttons. Use your voice instead.

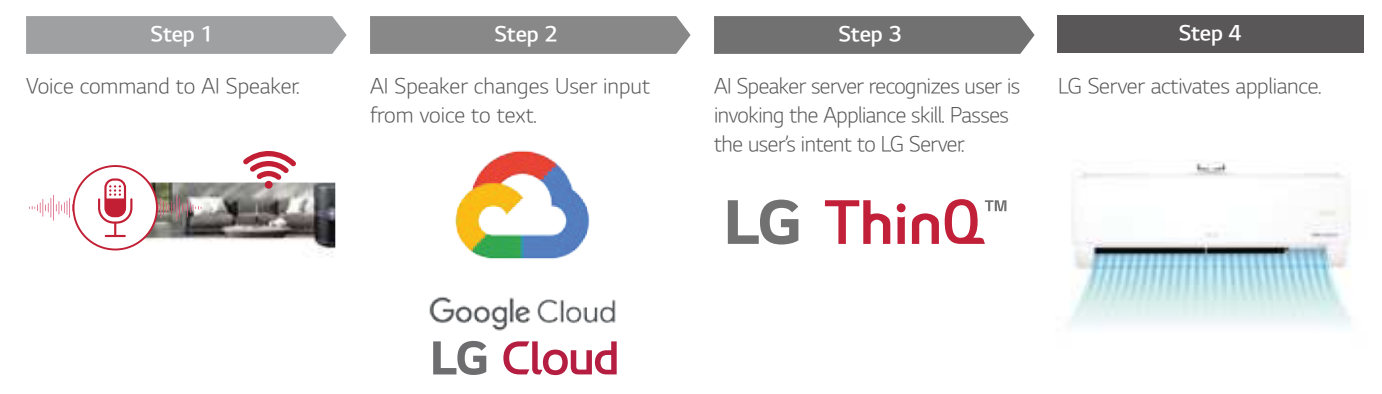

#### Voice control for a better life

- **Very intuitive** : It has never been that simple to control a device.
- **Accessible to everyone** : Young to elder people. Increase your comfort by asking so.
- **Time saving** : Don't look for the remote control anymore, just say it with your voice instead.

※ LG SmartThinQ is now renamed to LG ThinQ  
 ※ Smart features and voice assistant product may vary by country and model Check with your local retailer or LG for service availability.

Don't Worry!  
Now, breathe healthily



# DUALCOOL

with Air Purification



Cooling + Heating + Air purification



Comfort 365 days

Removes Ultrafine dust with



Ion Diffuser &  
Micro Dust filtering system

Real-time control & monitoring with



LG ThinQ APP



## Key Feature

### Air conditioner and air purifier in one

PM1.0 sensor is automatically activated and filtration system uses 5 million ions to capture and remove microscopic dust particles.

Step 1	Step 2	Step 3	Step 4
<b>PM 1.0 Auto Sensing</b> Detecting indoor dust concentration.	<b>Ion Diffuser</b> 5 million negative ions emitted through the air attach to the microscopic particles.	<b>Filtration System</b> Effective particle capture. (Dust Filter / Micro Dust Filter)	<b>Display - Indoor Air Quality status</b> Display total IAQ. (4 colors) <small>※ IAQ : Indoor Air Quality</small>
			Clean <span style="float: right;">Polluted</span>

※ Formerly branded LG SmartThinQ is now LG ThinQ  
 ※ Smart features and voice assistant product may vary by country and model Check with your local retailer or LG for service availability.

### Four seasons of breeze

Enjoy comfort in all four seasons with cooling, heating, and air purification.

Comfort 365 days



### 4-Way Swing (Indirect Air Flow)

Cool air reaches out to the entire room regardless of where the air conditioner is installed.

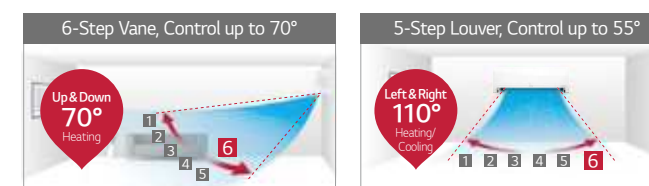

### Conveniently manage air quality with the LG ThinQ app

Let's check now! History of your air quality by LG ThinQ.

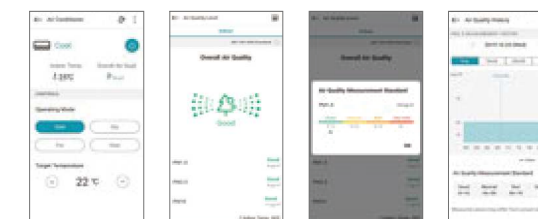

### 10-Year Inverter Compressor Warranty











With confidence in product quality and a desire to enhance the lives of customers, LG provides a 10-year warranty on the Residential Air Conditioners' Inverter Compressor.



# LINE-UP

## INDOOR UNIT

○ Single Split Only   ● Compatible   ● Multi Split Only











MODEL	KBTU	5	7	9	12	15	18	24		
	KW	1.5	2.1	2.6	3.5	4.2	5.3	7.0		
ARTCOOL	Gallery				○ A09FTNSF	○ A12FTNSF				
	Mirror			● AM07BPNSJ	○ AC09BQNSJ	○ AC12BQNSJ	○ AC18BQNSK	○ AC24BQNSK		
	Silver				○ AC09SQNSJ	○ AC12SQNSJ	○ AC18SQNSK			
	Prestige				○ F09MTNSM	○ F12MTNSM				
	Air Purification				○ AP09RTNSJ	○ AP12RTNSJ				
	Deluxe			● DM07RPNSJ	○ DC09RQNSJ	○ DC12RQNSJ	○ DC18RQNSK	○ DC24RQNSK		
	DUALCOOL	Deluxe 2				○ DC09RTNSJ	○ DC12RTNSJ			
		Standard Plus		● PM05SPNSJ	● PM07SPNSJ	○ PC09SQNSJ	○ PC12SQNSJ	● PM15SPNSJ	○ PC18SQNSK	○ PC24SQNSK
		Standard 2				○ S09ETNSJ	○ S12ETNSJ	○ S18ETNSK	○ S24ETNSK	
		Standard				○ S09EQNSJ	○ S12EQNSJ	○ S18EQNSK	○ S24EQNSK	
Standard 3					○ S09ESNSA	○ S12ESNSJ				

※ Refer to multi split line up for 5, 7, 15KBTU indoor unit connection.

# LINE-UP

## OUTDOOR UNIT

○ Single Split Only   ○● Compatible   ● Multi Split Only

MODEL	KBTU	9	12	14	16	18	21	24	27	30	
	KW	2.6	3.5	4.1	4.7	5.3	6.2	7.0	7.9	8.8	
ARTCOOL	Gallery		○ A09FTUL2	○ A12FTUL2							
	Mirror		○ AC09BQUA3	○ AC12BQUA3			○ AC18BQUL2		○ AC24BQU24		
	Silver		○ AC09BQUA3	○ AC12BQUA3			○ AC18BQUL2				
	Prestige		○ F09MTU24	○ F12MTU24							
	Air Purification		○ AP09RTUA3	○ AP12RTUA3							
	Deluxe		○ DC09RQUL2	○ DC12RQUL2			○ DC18RQUL2		○ DC24RQU24		
	DUALCOOL	Deluxe 2		○ DC09RTUA3	○ DC12RTUA3						
		Standard Plus		○ PC09SQUA3	○ PC12SQUA3			○ PC18SQL2		○ PC24SQU24	
		Standard 2		○ S09ETUA3	○ S12ETUA3			○ S18ETUL2		○ S24ETU24	
		Standard		○ S09EQUA3	○ S12EQUA3			○ S18EQU24		○ S24EQU24	
Standard 3		○ S09ESUA3	○ S12ESUA3								



---

# WALL MOUNTED

ARTCOOL | Prestige | DUALCOOL with Air Purification | Deluxe | Standard Plus | Standard



# ARTCOOL SERIES

---



## ARTCOOL Gallery DUAL Inverter

The design of LG air conditioners is fashionably elegant in such a way that it reigns supreme compared to others. Customise your space.



## ARTCOOL Silver DUAL Inverter



## ARTCOOL Mirror DUAL Inverter

In addition to modern lines and classic style, LG ARTCOOL offers the most outstanding air conditioning solution in a complete and attractive package.

# DUALCOOL SERIES



## PRESTIGE DUAL Inverter

LG Prestige offers one of the most comprehensive air conditioning solutions by providing supreme energy efficiency and a tranquil environment.



## DUALCOOL WITH AIR PURIFICATION

Enjoy a comfortable home throughout all four seasons with cooling, heating and air purification.



## DELUXE DUAL Inverter

LG Deluxe's minimalist design combines with advanced technology to go above and beyond the essential elements of an air conditioner.



## STANDARD PLUS DUAL Inverter

The LG Standard Plus boasts compact size, powerful cooling performance and convenient, sleek design.



## STANDARD DUAL Inverter

LG Standard features all the sophistication of a modern residential air conditioner integrated with LG's advanced technology.

# FEATURE OVERVIEW

		INVERTER COMPRESSOR 10 YEAR WARRANTY			CORE TECH	SMART	ENERGY EFFICIENCY			
					Dual Inverter Compressor	Voic Control	Embedded Wi-Fi	Smart Diagnosis	Active Energy Control	Energy Display
		Cooling	Heating							
	Gallery	9k	12k		●	●	●	●	●	●
ARTCOOL	Mirror	9k 12k 18k 24k			●	●	●	●	●	●
	Silver	9k 12k 18k			●	●	●	●	●	●
	Prestige	9k 12k			●	●	●	●	●	●
DUALCOOL	Air Purification	9k 12k			●	●	●	●	●	●
	Deluxe	9k 12k 18k 24k			●	●	●	●	●	●
	Deluxe 2	9k 12k			●	●	●	●	●	●
	Standard Plus	9k 12k 18k 24k			●	●	●	●	●	●
	Standard 2	9k 12k 18k 24k			●	●	●	●	●	●
	Standard	9k 12k 18k 24k			●	●	●	●	●	●
	Standard 3	9k 12k			●	●	●	●	●	●

Feature may vary for each model.

1. When connected to Multi Outdoor unit, Silent Mode 3dB is working by simply setting the dip switch on the PCB of the outdoor unit.
2. When combines with 40kbtu, Cooling A+, Heating A
3. Wi-Fi Ready : can be connected by using Wi-Fi controller (PWFMDD200)
4. Please refer to the specifications of Multi outdoor units.

# FEATURE OVERVIEW

COMFORT	HEALTHCARE	DURABILITY	FAST COOLING & HEATING	MULTI						
Comfort Air (Indirect Cooling/ Heating)	Low Noise 19dB	Silent Mode 3dB	Ultra Dust Sensing (PM 1.0)	Plasmaster Ionizer <sup>PLUS</sup>	Gold Fin™	Auto Cleaning	Jet Cool	4 Way Swing	Fast Heating	Compatible
●	●	●	●	●	●	●	●	3 way	●	●
●	●	●	●	●	Black Fin	●	●	●	●	●
●	●	●	●	●	●	●	●	●	●	●
●	●	●	●	●	●	●	●	●	●	●
●	●	●	●	●	●	●	●	●	●	●
●	●	●	●	●	Black Fin	●	●	●	●	●
●	●	●	●	●	●	●	●	●	●	●
●	●	●	●	●	Black Fin	●	●	●	●	●
●	●	●	●	●	●	●	●	●	●	●
●	●	●	●	●	●	●	●	(18/24k Only)	●	●
●	●	●	●	●	●	●	●	●	●	●

# UNIQUE FEATURES

## Smart

Enjoy anytime, anywhere access to your air conditioner with LG's ThinQ technology.

## Energy Efficiency

LG's revolutionary inverter technology provides world-class energy efficiency by minimising energy consumption.

## Perfect healthcare

The PM 1.0 auto sensor combined with advanced filtration technologies protect users from harmful substances such as micro-dust, viruses, allergens, and odors.

## Fast Cooling & Heating

Regardless of the outdoor temperature, LG air conditioners distribute cold or hot air fast, reaching every corner of even your largest rooms with powerful cooling or heating.

## Extreme Durability

In any environmental conditions, LG's air conditioners can bring customers peace of mind through product durability.

## Comfort

LG air conditioners provide a comfortable indoor environment with low noise levels and optimized vane adjustment capability that ensures even air flow.

## Quick & Easy Installation

Installation has never been easier as with the delicately designed installation elements of LG air conditioners

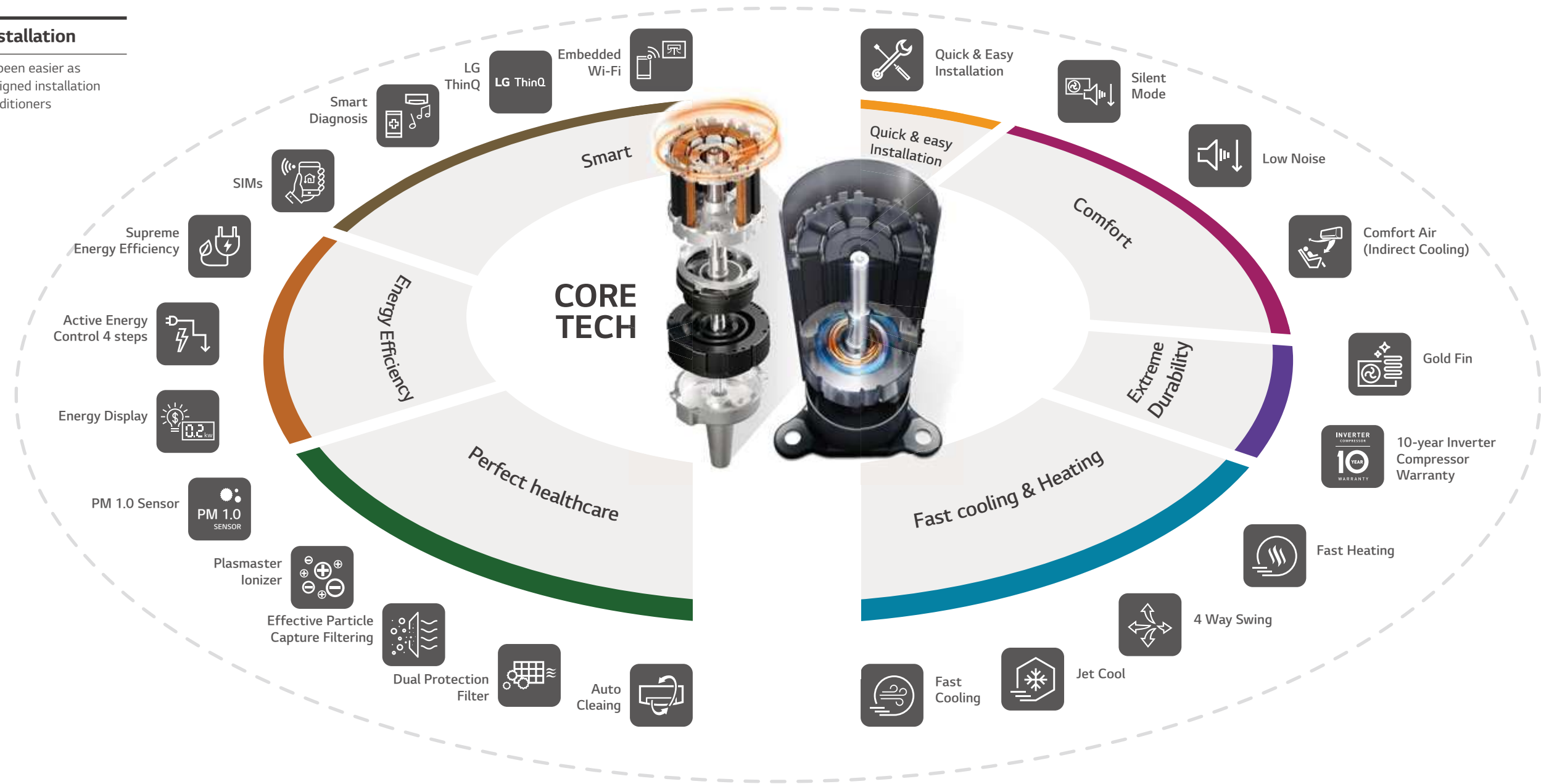

# CORE TECH



## Dual Inverter Compressor

### • What is the Dual Inverter Compressor?

A compressor is the heart of an air conditioner, and monitoring whether it works properly, effectively, or noisily that can cause stress as well as cost more money. LG's Dual Inverter Compressor provides an effective solution, resulting in an air conditioner that cools faster, lasts longer, and operates quieter than conventional models.



### • How it Works

#### Varied-Speed Dual Rotary

A compressor motor with a wider rotational frequency that is energy efficient and has a higher volumetric quick cooling capacity than any conventional compressors.

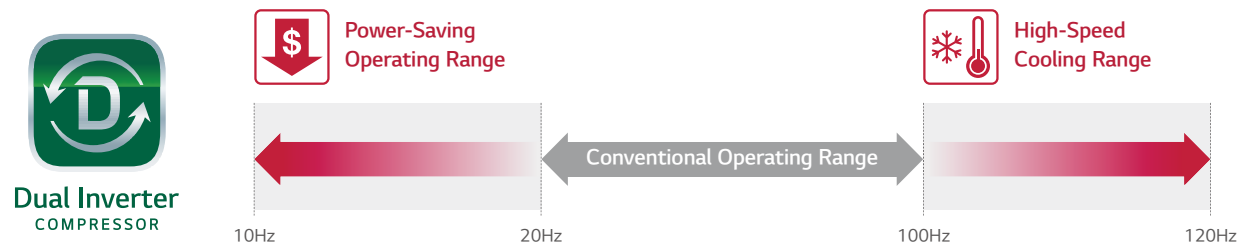

### • Product Reliability Improvement

The Dual Inverter Compressor reduces the vibration and with it the sound pressure levels. The reduction in vibration reduces the possibility of fractures occurring in the the surrounding pipework.

# CORE TECH



## R32 Refrigerant

- R32 is more environmental friendly compared to former refrigerant

### • Pain Point

Due to accelerated global warming and the destruction of the ozone layer, various international conventions and meetings are held to enhance restrictions to the use of refrigerant or enforce the use of eco-conscious refrigerants. In order to reduce environmental destruction, refrigerant R32 is internationally acclaimed for being Eco-friendly. This low volume refrigerant is as efficient as any conventional refrigerant but boasts a 68% reduced global warming potential.



### • How it Works

Utilising a small amount of the R32 refrigerant also qualifies it to be a highly green efficient system.

#### Alleviate Global Warming & Ozone Layer Destruction

R32 efficiently works even in small volume compared to existing R410A refrigerant, which decreases potential hazard of global warming.

	R410A	R32
Composition	Blend of R32 50% + R125 50%	Pure R32 (No blend)
GWP (Global Warming Potential)	2087.5	675

#### High Compressibility

R32's high compressibility rate gives more powerful cooling performance and efficiency compared to existing refrigerant R22 and R410A.

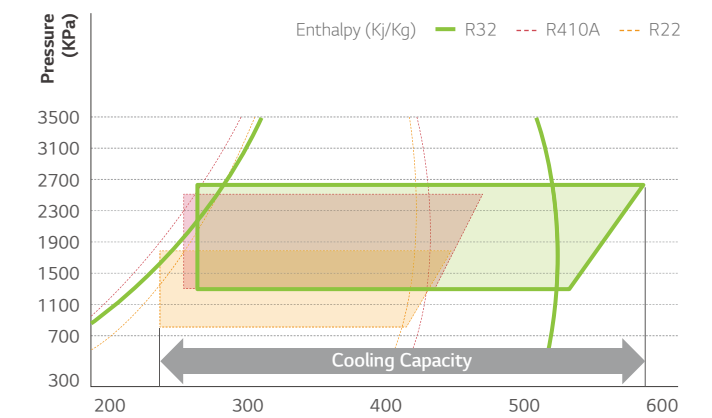

### • Benefit

Eco-conscious refrigerants reduce environmental pollution.

# SMART



## Embedded Wi-Fi

Control your air conditioners by using Android or iOS based smartphones. This advanced technology provides you many benefits.

### • LG ThinQ



Download the LG ThinQ app from Google or Apple app stores.



LG ThinQ

### • How it Works

#### Embedded Wi-Fi modem

Enable "LG ThinQ" on your air conditioner.



By using the embedded Wi-Fi modem, get ready for innovation without boundaries.



#### Easy Registration and Log-in

Follow the interactive set-up LG Account steps that will activate smart ThinQ's impressive features.

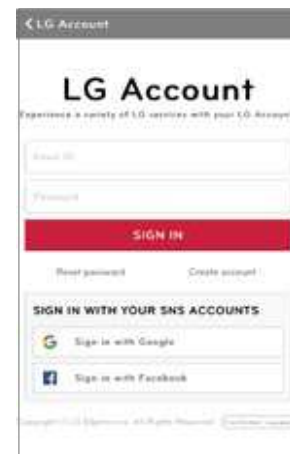

#### Wi-Fi Connectivity

Each individual member of your family can customise the air conditioner temperature and fan speed accordingly and then save the settings in their app to run it later. These settings can be saved for each air conditioner too.

#### Multiple Devices



\* Can be controlled by multiple users, but not simultaneously

#### Multi-Control



# SMART

### • Benefit

#### Simple operation for various functions

On/Off, Current Temp



Mode, Set Temp



Vane Control



#### Straight-forward management



Reservation



Energy Monitoring



Smart Diagnosis



Filter Management



#### Integrated Home Appliances Control

Monitor and control your LG appliances from one place.



Access your air conditioner anytime and from anywhere with a Wi-Fi equipped device and LG's exclusive control app, ThinQ.



# SMART

## Smart Diagnosis

Smart Diagnosis allows you to check setup, installation, troubleshooting and other information conveniently from your smartphone.

\* Specifications may vary for each model.  
\* When connected to Multi ODU, Smart Diagnosis function may not be supported.

### What is Smart Diagnosis?

Smart Diagnosis allows users to conveniently check setup, installation, troubleshooting and other information directly from a smartphone.

\* Builds upon widespread smartphone use and offers greater USP diversification  
\* Perfect for consumers who are unable to view information about their air conditioner via a display or remote control.

### How it works

By using "LG ThinQ" App and clicking "Start Smart Diagnosis", monitor and check diagnosis results conveniently via Wi-Fi.



\* When the model doesn't provide embedded Wi-Fi, diagnose by buzzer sound with the same app and remote controller.

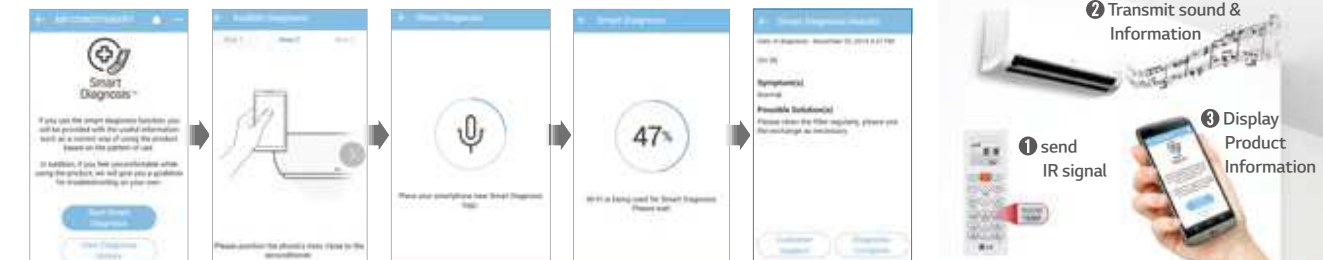

# SMART

### Benefit

Easily comprehensible error messages make detecting a solution and contacting the service center simple and convenient

#### For consumer



#### For Installer and SVC



- Easily check operational status of a product without a display or one that provides limited information
- Save energy by monitoring key operational information and power consumption
- Using the Maintenance Guide helps to improve device performance and increase product life-span.

- Understand the product better by easily confirming operational status and information
- Intuitively diagnose problems by comparing current and past usage data
- Maintain installation capabilities and reduce installation errors by quickly confirming device operational status



# SMART

## SIMs

By connecting SIMs chip, you can check the status of your air conditioner and diagnose problems from your smartphone.

\* Specifications may vary for each model.  
\* When connected to Multi ODU, SIMs function may not be supported.

### • What is the LG SIMs?

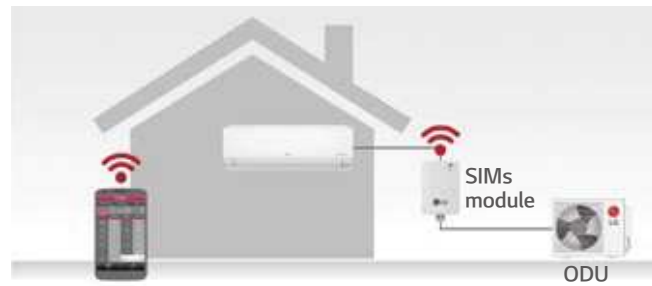

Monitor the status of your air conditioner and accurately diagnose problems by connecting it to a smartphone via a SIMs chip.

\* SIMs : Smart Inverter Monitoring System

### • How It Works

- SIMS App**
1. Use a SIMs chip to connect a smartphone to an air conditioner.
  2. Monitor and diagnose problems in real time using the SIMs app.

### • Benefit

**Easy Monitoring**  
Diagnose problems anytime, anywhere with a SIMs chip.

**Easy Diagnosis & Quick Response**  
Easily monitor IDU/ODU and diagnose problems. Save and review diagnostic data.

<p><b>Main</b> Current outdoor temperature Indoor temperature Inverter Comp frequency Operating opening Error code / Frequency limits Indoor. Outdoor fan speed</p>	<p><b>Indoor Unit</b> Indoor Unit Capacity / Operation Mode THM mode / REM mode FAN operating condition / EEV opening Room Temperature / Suction Temperature Intermediate Temperature Exit Temperature</p>
<p><b>Outdoor Unit</b> Frequency / Fan RPM DC Link / Input Current Input Voltage EEV operation mode Restart timer Compressor mode / EEV opening</p>	<p><b>Chart</b> Room Temperature Heat exchanger pipe temperature Compressor discharge temperature Frequency / Outdoor temperature Compressor suction temperature Electric current / Voltage</p>

**Certificate**  
 US Radio Standard  
 Canada Radio Standard  
 Australia Radio Standard  
 Europe Radio Standard

\* Smartphone Requirements (iOS : 6.1 or later; Android : 2.3 or later)

# SMART

## Low Refrigerant Detection

Early notification of low refrigerant protects your air conditioner from a risk of damage.

\* Specifications may vary for each model.  
\* Depending on the experimental conditions.  
\* When connected to Multi ODU, Low Refrigerant Detection function may not be supported.

### • How It Works

**Early Detection of Low Refrigerant Levels**  
The Air Conditioner is automatically shut down when low refrigerant level is detected.

- 3 Checkpoints for Low Refrigerant Level :**
- 1) The heat exchanger temperature is comparatively cool
  - 2) The outdoor unit is working properly
  - 3) The energy consumption is working under a standard pattern

If any of the above conditions are not met, for a maximum of 4 times, after 15 minutes of Air Conditioner operation, a Low Refrigerant level is detected and the Air Conditioner is shut down.

### Capacity and Effectiveness of the Refrigerant Levels

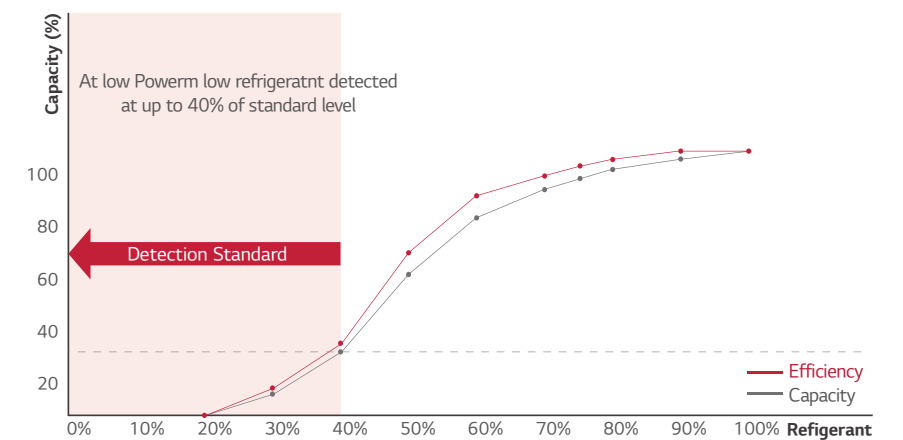

\* This function only works under the following conditions:  
 - Indoor/Outdoor temperature is up to 20 degrees Celsius  
 - Cooling and dehumidification mode

### • Benefit

**Longer Lifespan for Air Conditioner**

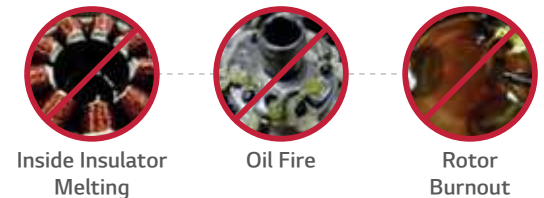

Notify You of Low Refrigerant Levels

When Low Refrigerant Level is detected, it alternately shows CH and 36 on the display.

\* Some models show CH and 38 alternately on the display.

# ENERGY EFFICIENCY

## Supreme Energy Efficiency

LG's revolutionary Inverter technology boasts powerful yet quiet performance while minimising energy consumption. With world-class energy efficiency, enjoy comfort as well as energy savings.

\* Based on H09AL Model  
\* Specifications may vary for each model.

### • High Efficient Compressor and Reversing Valve

#### Rotary Compressor and Motor Efficiency

The number of suction connections has been reduced from two to one to increase the efficiency of the refrigerant compression during low speed conditions. The DC motor in LG air conditioners remains unsurpassable incomparable to in the world's top class efficiencies.

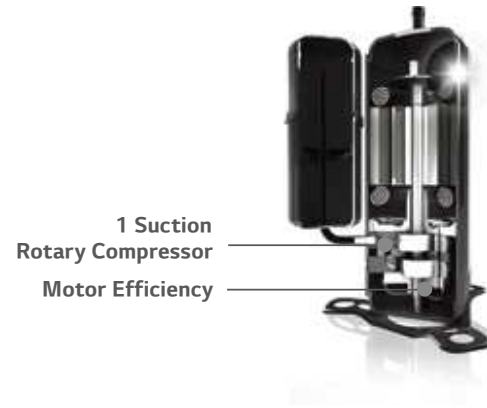

#### Bi-Stable Reversing Valve

The Input power of 4-way valve has been reduced to 0W by using a Bi-Stable type.



### • Improved Inverter Drive Efficiency

Used to optimise the time of current flow by controlling the number of converter switching according to energy consumption status. Displays comparatively higher performance and advanced energy efficiency than conventional Inverter air conditioner by reducing power loss with an advanced material component called SiC.

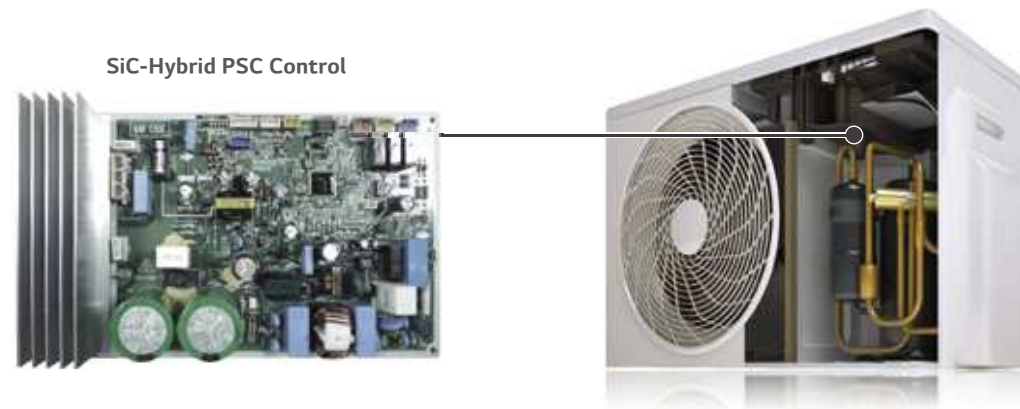

# ENERGY EFFICIENCY

## Active Energy Control 4 - Step

LG's Active Energy Control adjusts the energy consumption level and cooling capacity by controlling maximum frequency of the compressor motor.

\* Specifications may vary for each model.  
\* Depending on the experimental conditions.  
\* When connected to Multi ODU, Active Energy Control function may not be supported.

### • Concept & Benefit

Cooling a home can come at a high cost particularly during the hot summer months. Avoid those costs and save energy by taking advantage of LG's 4-Step Energy Control System.

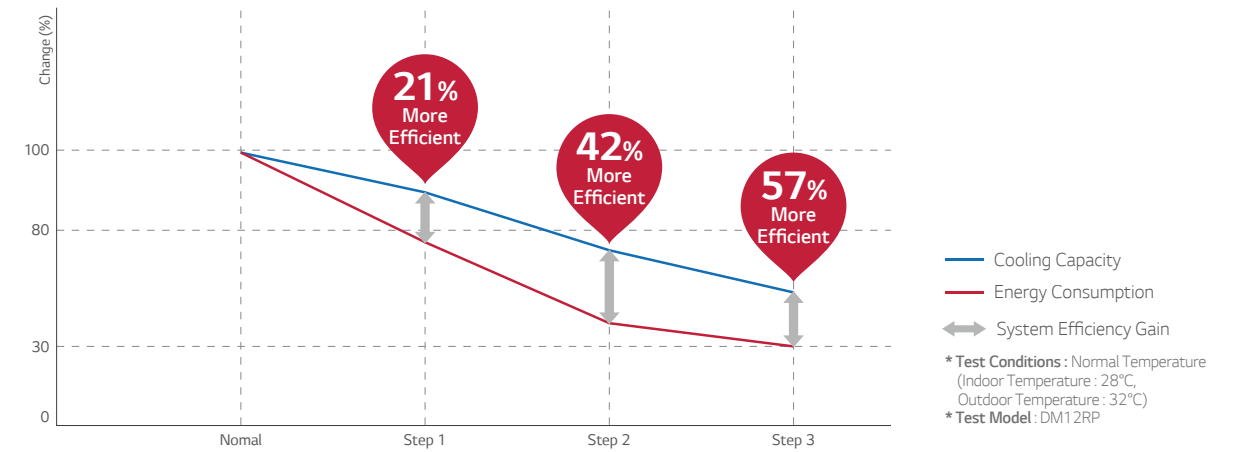

### • How It Works

<p><b>Normal.</b> 100% energy usage</p> <p>Many people and high-activity level</p>	<p><b>Step 1.</b> 80% energy usage</p> <p>Few people and moderate-activity levels.</p> <p>1 Clicks</p>
<p><b>Step 2.</b> 60% energy usage</p> <p>Fewer people and low-activity levels.</p> <p>2 Clicks</p>	<p><b>Step 3.</b> 40% energy usage</p> <p>Fewest people with no activity.</p> <p>3 Clicks</p>

# ENERGY EFFICIENCY



## Energy Display

LG's Energy Display panel monitors the amount of energy levels used. Reduce energy consumption while enjoying a comfortable indoor environment by checking your energy level directly on the AC panel.

\* Specifications may vary for each model.  
\* When connected to Multi ODU, Energy Display function may not be supported.

### • How it Works

#### Magic Display & Remote Control

With the push of a button on the remote control, indoor unit's LCD display shows the current and total energy use, thus making the users aware of reducing energy consumption.



### • Benefit

#### Nomal Mode

Current Setting Temp



press for 3 sec

#### Electric Power

Displays Current Energy Use



# PERFECT HEALTHCARE



## Plasmaster™ Ionizer<sup>PLUS</sup>

The powerful Plasmaster Ionizer protects you from bad odors and Escherichia coli and Staphylococcus in the surface with over 3 million ions to sterilize to make a safer, and cleaner environment.

\* Specifications may vary for each model.  
\* Depending on the experimental conditions.

### • How It Works

#### Sterilization and Deodorization (Utilizes Over 3 Million Ions)

Plasmaster Ionizer+ reduces E.coli and Staphylococcus in the surface with over 3 million ions.

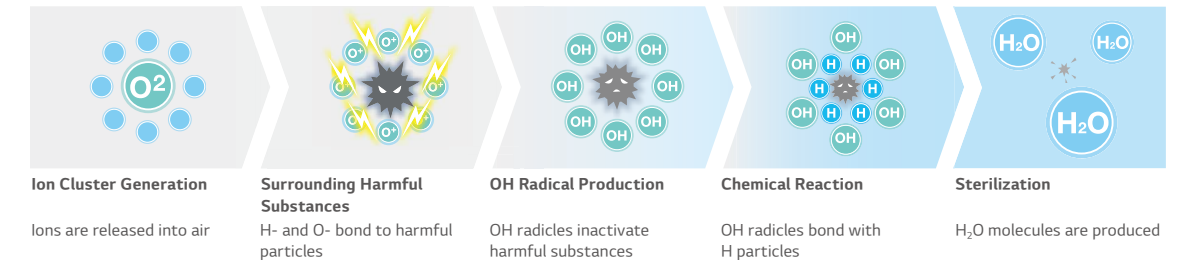

### • Test Result

#### Sterilization Performance Evaluations

Sterilize Bacteria E.coli over 99.9% in 30 min.

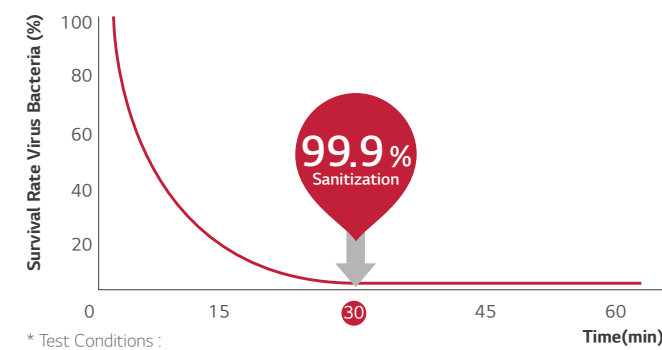

\* Test Conditions :  
Space : 52m<sup>3</sup> Chamber (measuring with the specimen in the center of test chamber)  
Temperature & Humidity : Normal  
Bacteria : E coil colon bacillus  
Tested by Intertek

Sterilize staphylococcus over 99.6% in 60 min.

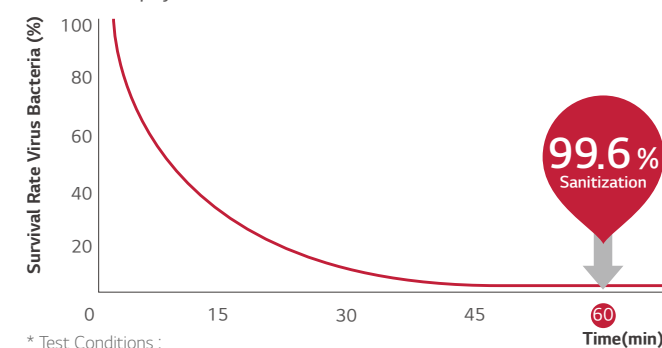

\* Test Conditions :  
Space : 52m<sup>3</sup> Chamber (measuring with the specimen in the center of test chamber)  
Temperature & Humidity : Normal  
Bacteria : Staphylococcus Aureus  
Tested by Intertek

#### 2.1 odor strength decrease in 60 minutes

An odor of measured as 2 European odor units (ouE/m<sup>3</sup>) or less indicates that the level of odor falls within permissible limits.

Odor Strength	1	2	3	4
Offensive odor substance sensitivity	Mountain smell	Indoor life smell	Bathroom smell	Food waste smell
Odor strength level	Light	Moderate	Strong	Very Strong



Odor strength reduce 3.6 → 1.5 / The Odor floating in the room as well as curtain and clothes.

\* Test conditions :  
Space : 8m<sup>3</sup> Chamber  
Temperature & Humidity : Normal  
Tested by Intertek

# PERFECT HEALTHCARE

## PM 1.0 Auto Sensor

As AC turns on, PM 1.0 sensor automatically operates to capture and remove microscopic dust particles including ultra fine dust.

\* Specifications may vary for each model.  
\* Depending on the experimental conditions.



- AQI(Air Quality Index) is displayed in unit of 1 within 8-999  $\mu\text{g}/\text{m}^3$ .
- AQI(Air Quality Index) may continuously change according to changes in the indoor environment.
- Overall cleanliness color is displayed based on the highest contamination level among fine dust(PM10), ultra fine dust(PM2.5), and super ultrafine dust (PM1.0).
- Overall cleanliness color is displayed in 4 levels according to the indoor contamination level.
- If dust concentration is high, the difference between the displayed dust concentration and the actual dust concentration may increase.

• During the operation, if you press PM SENSOR button, you can check the indoor cleanliness in each level.

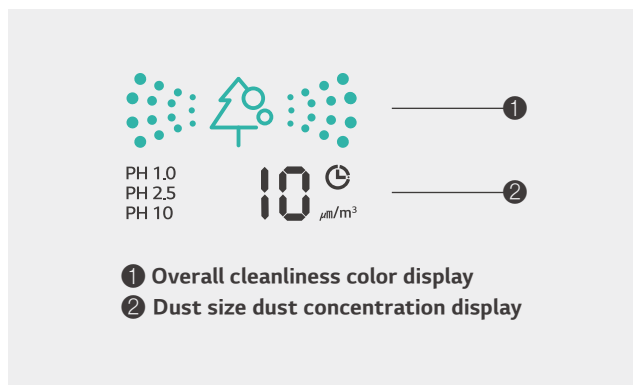

Color	Level	Display standard ( $\mu\text{g}/\text{m}^3$ )		
		Super ultra fine dust (PM 1.0)	Ultra fine dust (PM 2.5)	Fine dust (PM 10)
Green	Good	12 or less	12 or less	54 or less
Yellow	Normal	13 - 35	13 - 35	55 - 154
Orange	Bad	36 - 55	36 - 55	155 - 254
Red	Very Bad	56 or more	56 or more	255 or more

**Guide to dust particles' size**

- Fine dust : Dust with particle size of  $10\mu\text{m}$  or less (Generated from workplace combustion, vehicle exhaust, etc.)
- Ultra fine dust : Dust with particle size of  $2.5\mu\text{m}$  or less (Composed of ion component, carbon compound, and metal compound)
- Super Ultrafine dust\* : Dust with particle size of  $1.0\mu\text{m}$  or less (Cigarette smoke, etc.)

AQI(Air Quality Index) evaluation is carried out with LG standard test dust.

\* Minimum capturing size of particle :  $0.02\mu\text{m}$   
 ※ PM : Particulate matter is the sum of all solid and liquid particles suspended in air many of which are hazardous.  
 This complex mixture includes both organic and inorganic particles, such as dust, pollen, soot, smoke, and liquid droplets.

# PERFECT HEALTHCARE

## Dual Protection Filter

The Dual Protection Filter collects dust.

\* Specifications may vary for each model.  
\* Depending on the experimental conditions.

### • What is the Dual Protection Filter?

The Dual Protection Filter, designed to capture dust particles over  $10\mu\text{m}$  in size, first line of defense against finer particles.

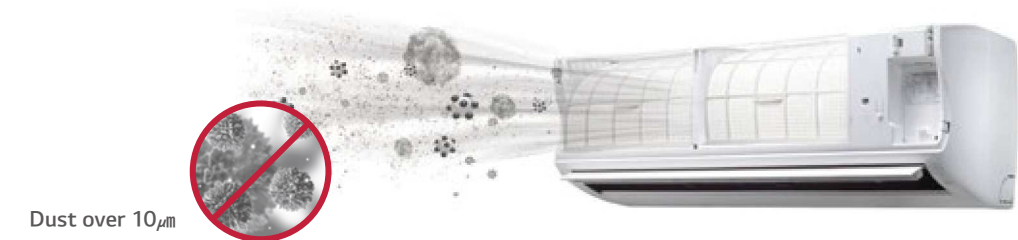

### • Additional Benefit

**Easy to Open**

Easily detachable full surface cover helps clean the air conditioner flawlessly.



**Easy to Clean**

The filter is designed for easy handling and quick cleaning, which lengthens its lifespan.



# PERFECT HEALTHCARE



## Auto Cleaning

The interior of the air conditioner is maintained clean by drying off the heat exchanger, then sterilizing the interior once more.

\* Specifications may vary for each model.

### • Pain Point

The main cause of odor within air conditioners is mold and bacteria growing on the heat exchanger. These germs can spread when the heat exchanger is wet.

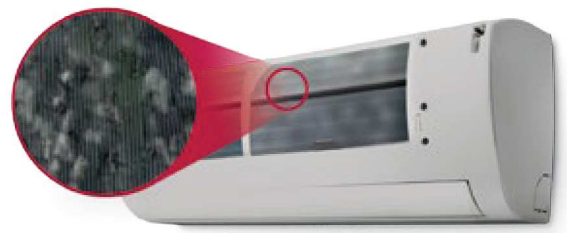

### • How It Works

#### Cleans Filter with Regular Air Flow

The comprehensive auto cleaning function prevents the formation of bacteria and mold on the heat exchanger, providing an enhancing environment.

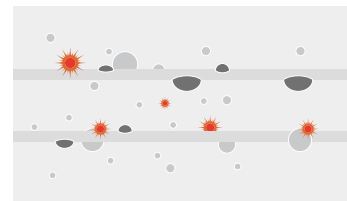

By dehumidifying, (some models are by dehumidifying and ionizing), the auto cleaning function prevents potentially harmful substances from forming on the surface of the heat exchanger.

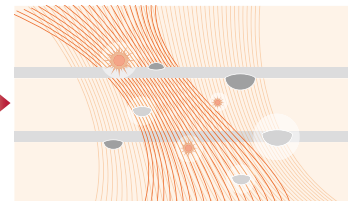

The indoor environment remains odorless with the advanced deodorizing function.



By preventing polluting of the heat exchanger caused by various germs and bacteria, the performance and life span of the air conditioner do not wither away even after a period of 10 years.

### • Benefit

#### Removes Harmful Particles

Auto Cleaning provides clean air by preventing bacteria, mold and odors that can otherwise accumulate in an indoor unit.



Bacteria Prevention



Odor Elimination



Mold Elimination

# FAST COOLING & HEATING



## Fast Cooling

The cool airflow reaches all the corners of the room, keeping the space cool and comfortable.

\* Specifications may vary for each model.  
\* Depending on the experimental conditions.

### • How It Works

#### Bigger Skew Fan

A 25% larger skew fan emanates highly powerful blasts of air.

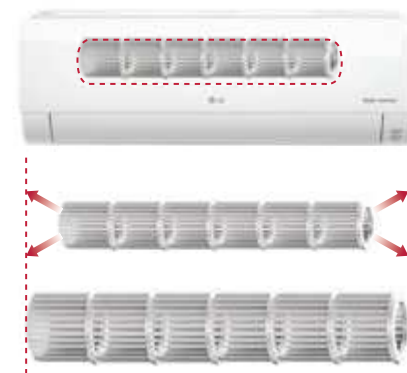

25% Larger (Fan Size)

#### Cooling Outlet

A larger, optimally designed cooling outlet emanates to large areas and cools spaces faster.

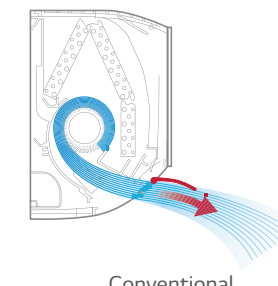

Conventional

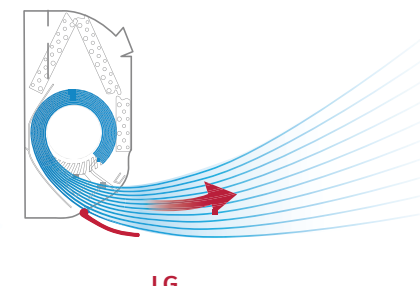

LG

### • Test Result

#### Test Result

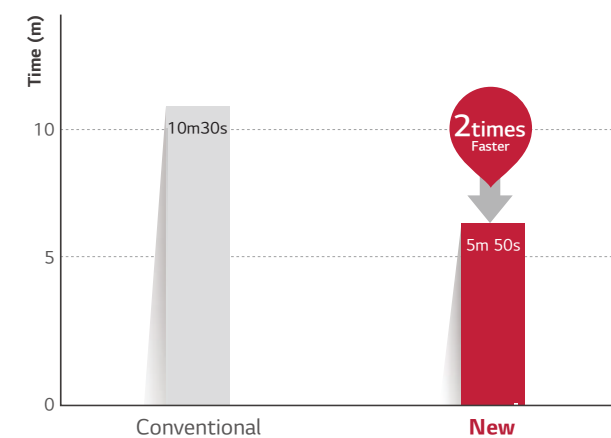

\* Test Conditions :  
: Indoor temperature 33°C, Outdoor temperature 35°C,  
Relative humidity 60%, Setting temperature 24°C

#### Changes in Temperature Over 30 Minutes



\* Test Conditions :  
Outdoor temperature : 35°C, Indoor temperature : 33°C,  
Humidity : 60%, Remote control : 24°C High

# FAST COOLING & HEATING

## Jet Cool

LG air conditioners provide optimized high-speed airflow, which can cool rooms faster while delivering cool air evenly in every direction.

\* Specifications may vary for each model.  
\* Depending on the experimental conditions.

### • How It Works

#### One Click "Jet Mode"

Reduces the temperature of outflowing air to 18°C for 30 minutes with just one click.

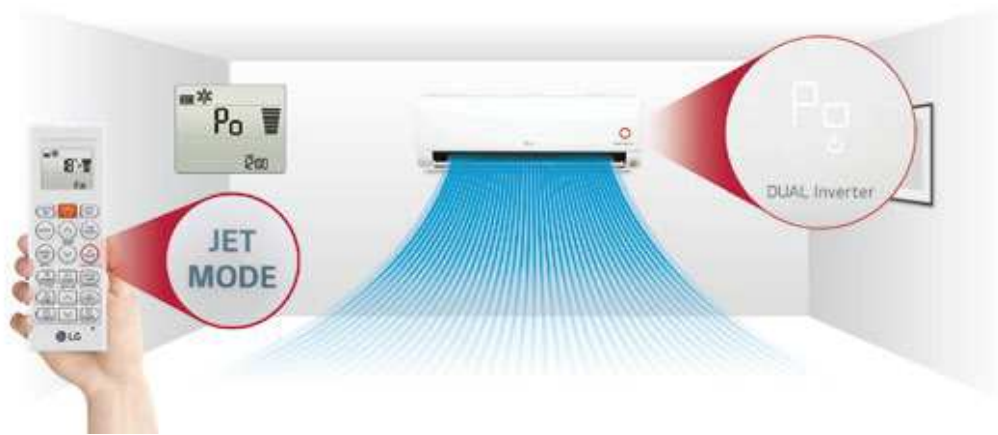

### • More Powerful Performance

By reducing the second vortex, which decreases airflow within the air outlet, and enlarging the fan size, the amount of airflow is increased to 13.0 CMM.



# FAST COOLING & HEATING

## 4-Way Swing

Cool air reaches out to the entire room regardless of where the air conditioner is installed

\* Specifications may vary for each model.

### • How It Works

#### 6-Step Vane, Control up to 70°

The vertical vane, which moves up and down, has 6 different settings including full-auto swing.

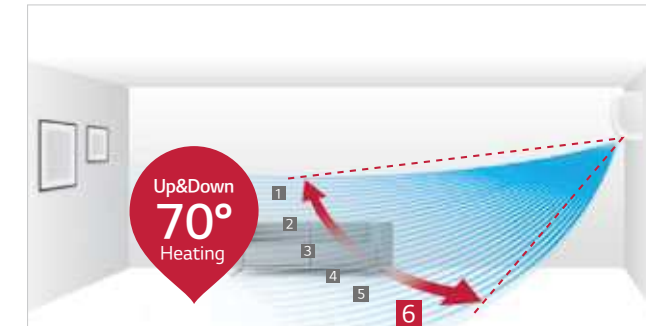

\* Angle can be different from each model and working mode.

#### 5-Step Louver, Control up to 55°

The louver, which sways left and right, has 5 different settings including full auto-swing.

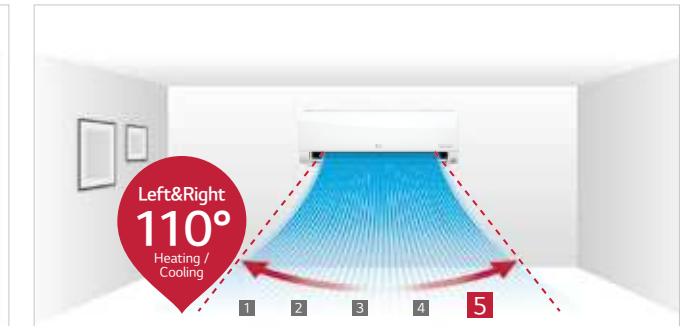

### • Easy and Simple Control

Airflow direction can be changed by LG ThinQ Wi-Fi app.

#### Up/Down Swing

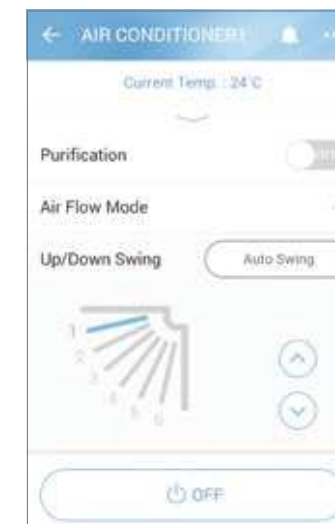

#### Left/Right Swing

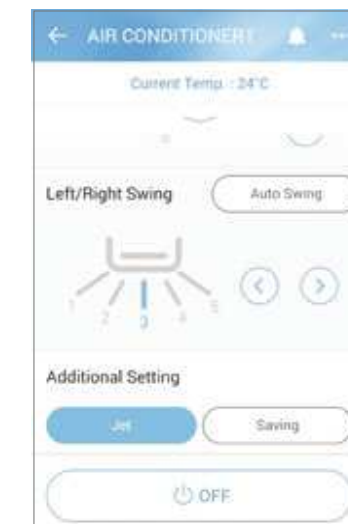

# FAST COOLING & HEATING



## Fast Heating

LG Residential Air Conditioners satisfy your heating needs while consuming less energy, by heating a wider space in a shorter period of time to create a warm and comfortable living environment.

\* Specifications may vary for each model.  
\* Depending on the experimental conditions.

### • How It Works

#### 4 way Auto Swing (Easy Airflow Control)

4 Way Auto Swing adjusts airflow based on the surrounding environment, allowing for optimal distribution of warm air to living areas and enabling quick heating.

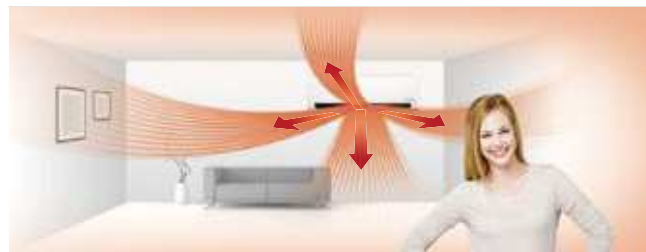

#### Vertical Airflow

When heating, the vane sends heated air downwards to maintain a pleasant and balanced room temperature.

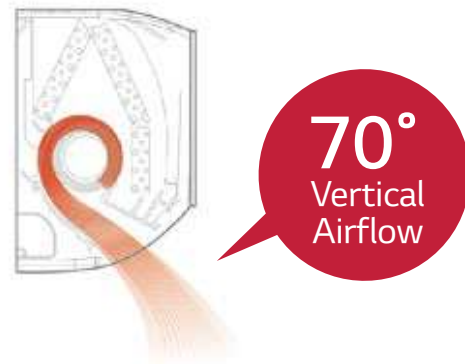

### • Benefit & Test Result

#### 22% Quick Heating

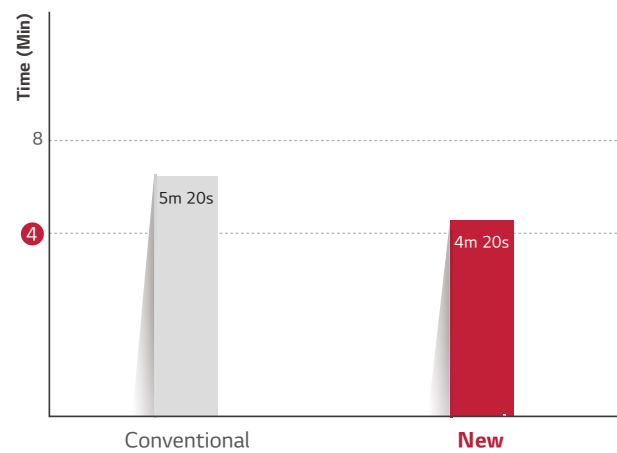

\* Test Conditions :  
Outdoor temperature : 7°C, Indoor temperature : 12°C,  
Humidity : 87%, Remote control : 30°C Power

#### Changes in Temperature Over 20 Minutes

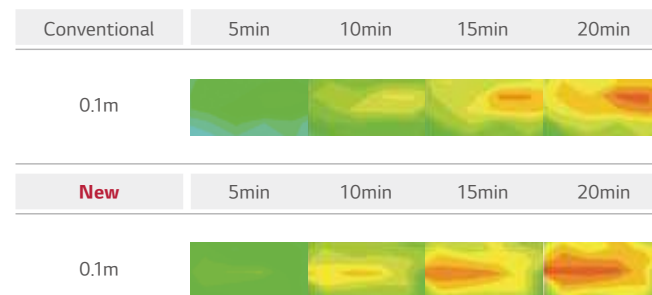

\* Test Conditions :  
Outdoor temperature : 7°C, Indoor temperature : 12°C,  
Humidity : 87%, Remote control : 30°C Power

# EXTREME DURABILITY



## 10-Year Inverter Compressor Warranty

With confidence in product quality and a desire to enhance the lives of customers, LG provides a 10-year warranty on the Residential Air Conditioners' Inverter Compressor.

\* Specifications may vary for each model.

### • What is the 10 Year Warranty?

With the 10-year warranty on the compressor, users can be assured of the functionality of our product for a longer period of time.



### • Benefit & Verification

#### Reliable Air Conditioner

Product safety is emphasized by offering a 10-year warranty on the compressor to reassure customers about product durability.



#### Verification

TUV Rheinland, Long Term Accelerated-reliability Test & High Marginal Test

\* Long Term Accelerated-Reliability test  
LG's unique testing method with reinforced operating condition for a product life assurance to test and determine the product life cycle in a short period of time by accelerating the life cycle.

\* High Marginal Test  
Test method to secure durability in various adverse conditions that may occur in the field by performing comp reliability test against higher pressure and temperature than the designed range of pressure and temperature which the comp operates in.

\* Verification obtained from TUV Rheinland for 10-year product life cycle



# EXTREME DURABILITY



## Gold Fin™

The Gold Fin™ coating protects the surface of the heat exchanger from unnecessary wear and corrosion.

\* Specifications may vary for each model.  
\* Depending on the experimental conditions.

### • How It Works

#### Corrosion-resistant protective layer

The gold-colored special coating on the fin of the heat exchanger prevents corrosion, extending the life of the unit.

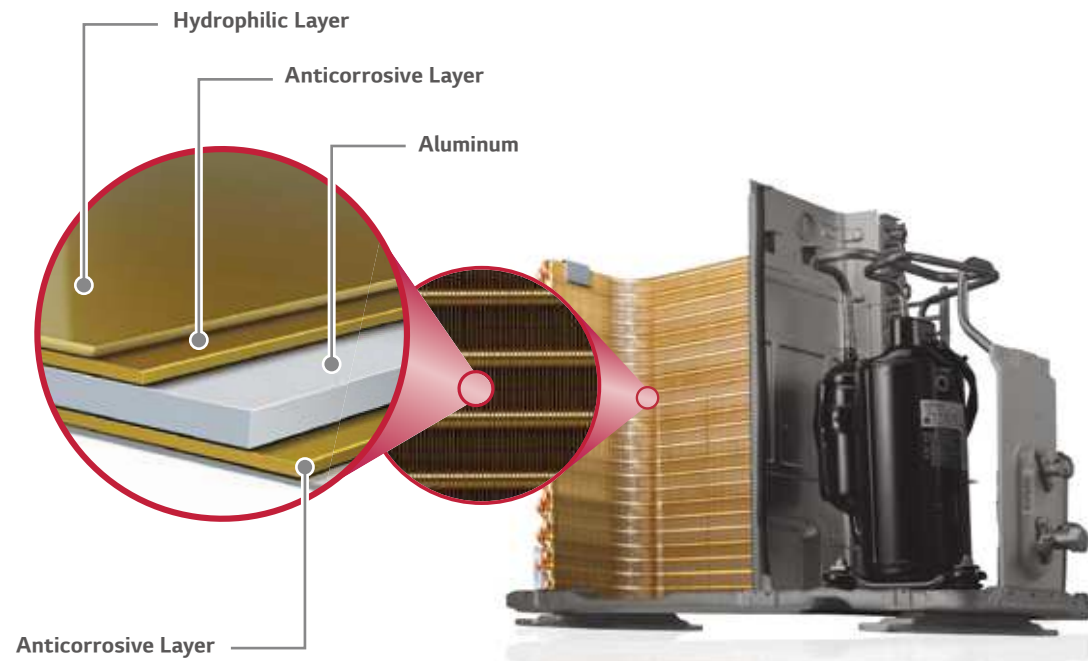

### • Test Result

#### Conventional Fin



#### Gold Fin™



\* Test result: 360 hrs. after being exposed to sodium chloride

# COMFORT



## Comfort Air (Indirect Cooling)

LG provides pure hygienic and temperature regulated atmosphere surrounding your living space. An automatic vane angle adjustment sets perfect vane angle and air volume.

\* Specifications may vary for each model.

### • Concept

Comfort Air changes the air flow angle to ensure that air is directed away from occupants to promote more comfortable environments optimized for sleeping and more.

### • How It Works

#### Control Panel



#### Comfort Vane

This option conveniently sets an AC's louvers to a preset position so that outflowing air is directed away from a room's occupants.

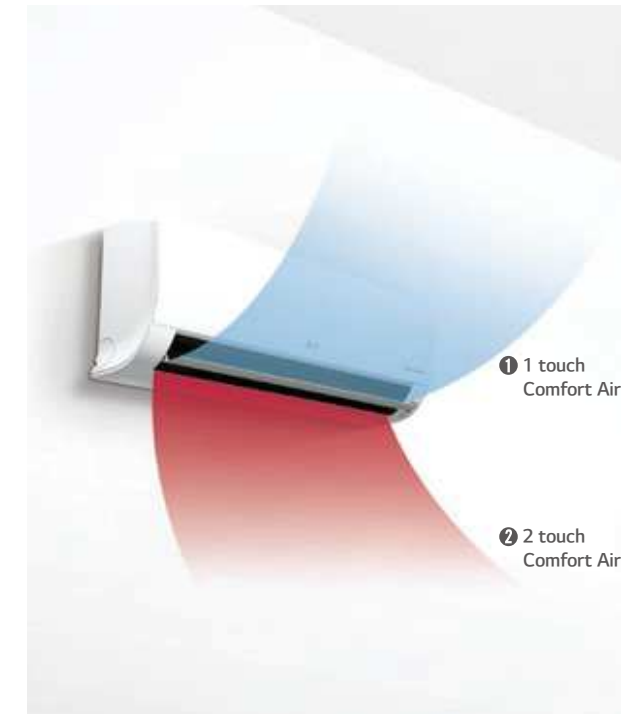

#### Scene 1: Inclines to a maximum 80° angle.

Sets vane angle to highest position : Optimized for gentle airflow cooling.

#### Indoor Unit Display



#### Remote Controller Display



#### Scene 2: Declines to a maximum 10° angle.

Sets vane angle to lowest position : Optimized for gentle airflow heating.

#### Indoor Unit Display



#### Remote Controller Display





# COMFORT

## Low Noise

LG Air Conditioners operate at 19dB low noise level, moreover provide healthy soft air by just 1 touch.

\* Specifications may vary for each model.

### • How It Works

#### LG's Unique Skew Fan

By minimizing the surface pressure of the fan blade when in contact with the air, the noise produced by the air conditioning unit is reduced to a remarkably low level.



#### BLDC Fan Motor

With strong torque and powerful ND magnetism as well as precise speed control of 13 different steps for smooth operation, the BLDC motor provides substantial air volume and high static pressure, while keeping electrical and mechanical noise lower, and making high-speed operation available.

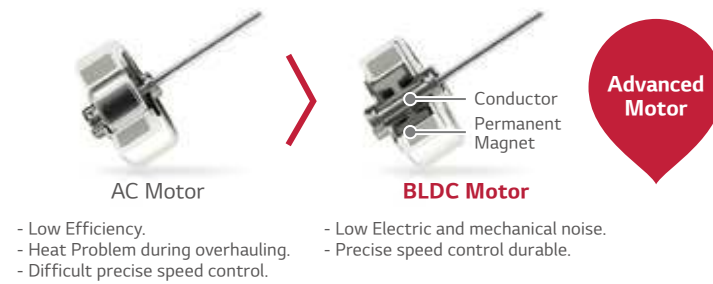

#### ALVC (Active Low Vibration Control)

A speed-error component estimates the load to compensate for imbalances, which are the primary causes of vibration and noise, enabling the rotation of the motor without vibration at low Hz levels.

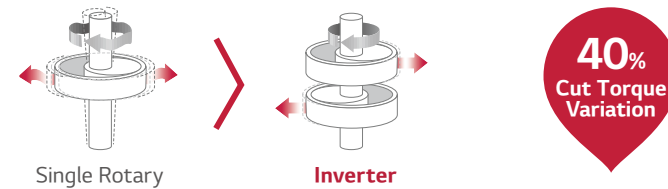

### • Benefit

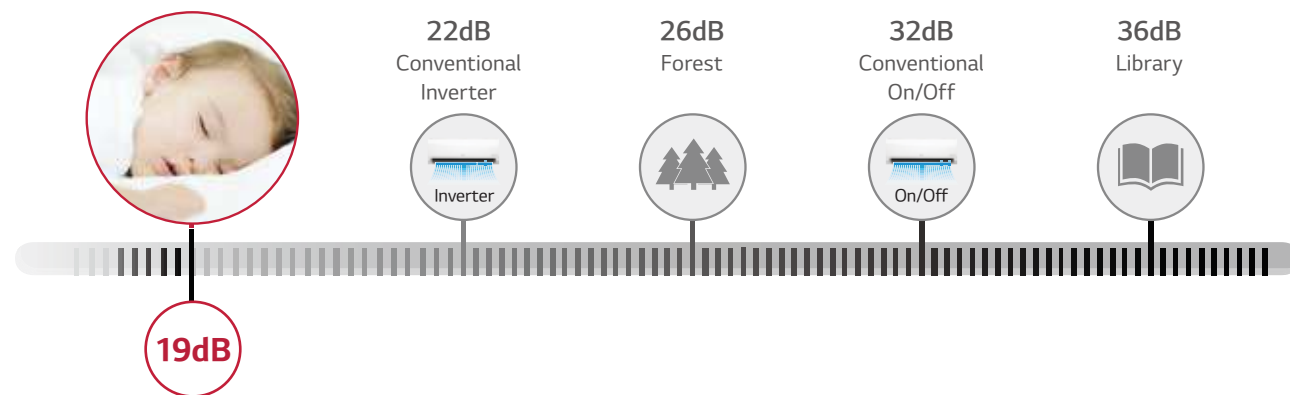

# COMFORT

## Silent Mode

Silent mode ensures a tranquil and serene experience for the user by reducing noise disturbances while you are resting.

\* Specifications may vary for each model.

\* Depending on the experimental conditions.

\* When connected to Multi Outdoor unit, Silent Mode is working by simply setting the dip switch on the PCB of the outdoor unit.

### • How It Works

In Silent Mode, the overall sound level of the outdoor unit drops by up to 3dB and the sound level of the indoor unit also decreases.

#### Press the Silent Button

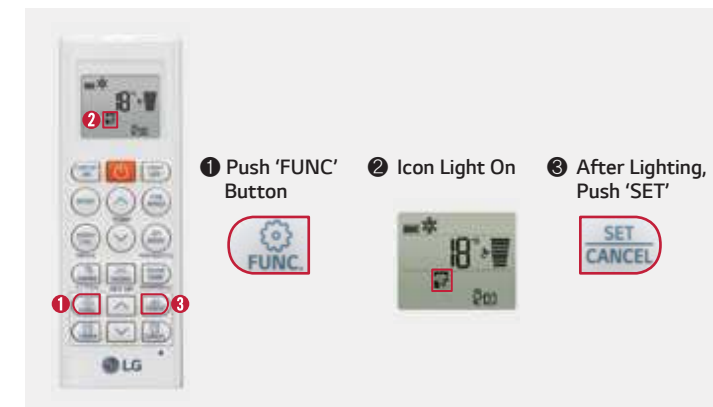

#### Controls the Outdoor Compressor



### • Test Result

#### Noise Comparison Graph

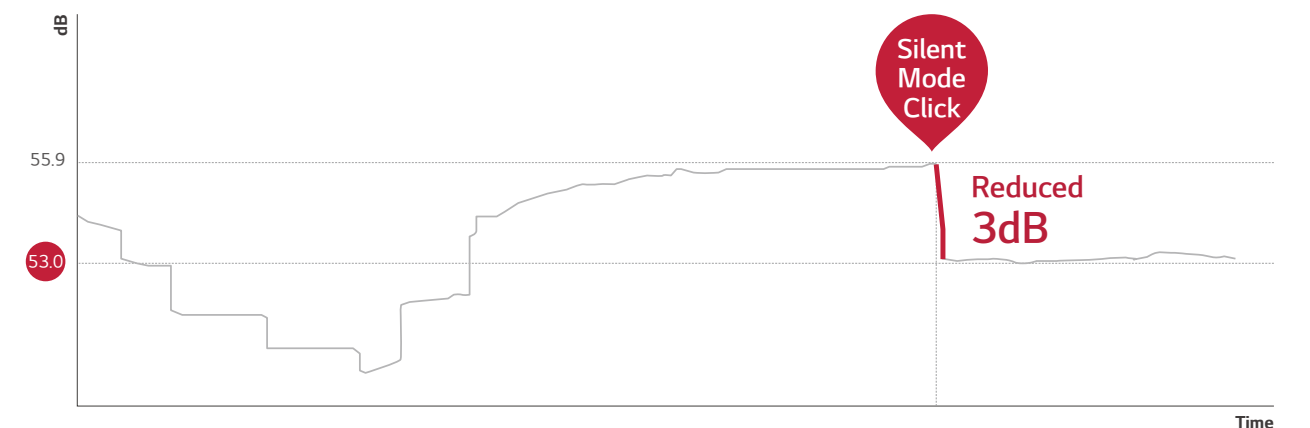

\* Test Conditions

Spec : Selecting Silent Mode reduces the noise of an outdoor fan unit by 3dB  
Assessment : 36.2 dB emitted from center/side of unit at a distance of 1m.

# COMFORT



## Quick & Easy Installation

LG air conditioner is designed for an easy and efficient installation, making possible to install several units in a short period of time

\* Specifications may vary for each model.

### • Concept

By reducing the manpower and time required for installation, it is now possible to install more units in less time.

### • How It Works

#### One Simple Packing Box

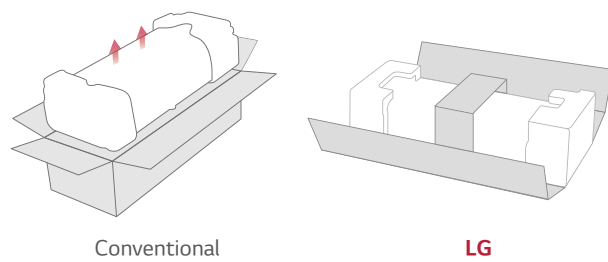

#### Installation Plate Improvement

LG's installation plate is larger and customized to reduce installation time.

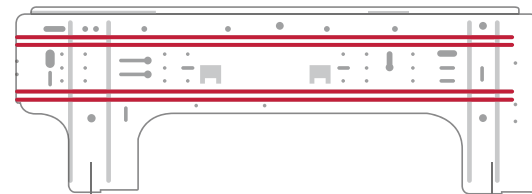

#### Installation Support Clip

A support clip creates adequate space between the wall and the unit for easier installation.

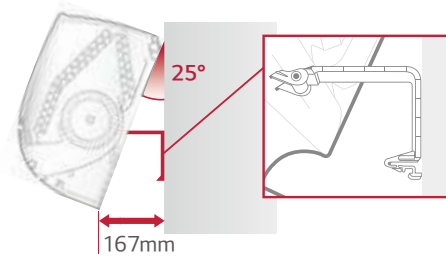

#### Wider Tubing Space

The space provided for tubing facilitates the whole installation process and hides the unorganized parts, making it appear clean and tidy.

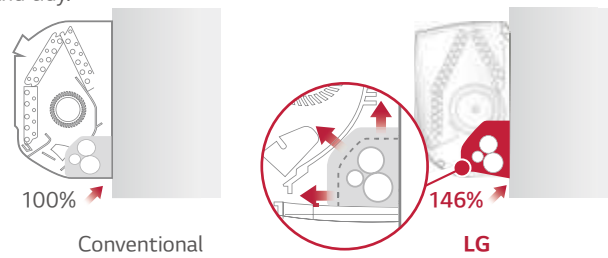

#### Detachable Bottom Cover

The air conditioner's bottom cover is detachable for easier installation and access.

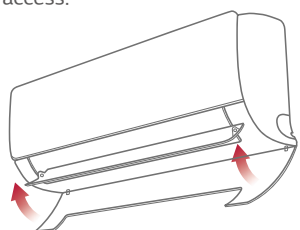

#### Quick button for running test

The test button is conveniently located and easy to find.

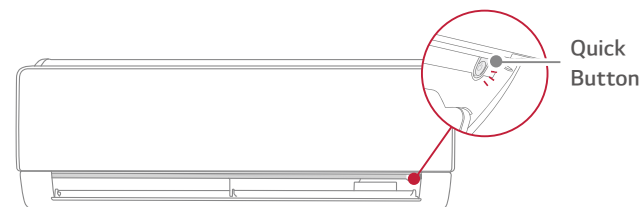











# STANDARD 3



NEW



LG participates in the ECP programme for EUROVENT AC program. Check ongoing validity of certification: [www.eurovent-certification.com](http://www.eurovent-certification.com)

Smart Diagnosis	Active Energy Control	Energy Display	Auto Cleaning	Jet Cool	2 Way Swing (9k, 12k)	Fast Heating
Gold Fin™	Comfort Air	Low Noise 19dB (9k, 12k)	Silence Mode	Quick & Easy Installation		

## • Single Combination

UNIT				9K	12K	
INDOOR				S09ES NSA	S12ES NSJ	S12EW NSJ
Capacity	Cooling	Min / Rated / Max	W	890/2500/3400	890 / 3500 / 4040	890 / 3500 / 4040
	Heating	Min / Rated / Max	W	890/3200/3700	890 / 4000 / 5100	890 / 4000 / 5100
	Heating -7°C	Rated	W	2700	3600	3600
Power Input	Cooling	Rated	W	715	1080	1080
	Heating	Rated	W	860	1050	1050
EER			W / W	3.50	3.24	3.24
S.E.E.R.				6.5	6.6	6.6
P design C			kW	2.5	3.5	3.5
COP			W / W	3.72	3.81	3.81
S.C.O.P. (Average / Warmer)				3.8 / 4.2	4.0 / 4.9	4.0 / 4.9
P design H (Average / Warmer)			kW	2.3 / 1.2	2.5 / 1.3	2.5 / 1.3
Energy Label (A+++ to D Scale)	Cooling			A++	A++	A++
	Heating (Average / Warmer)			A / A+	A+ / A++	A+ / A++
Annual Energy Consumption	Cooling		kWh	135	186	186
	Heating (Average / Warmer)		kWh	847 / 400	875 / 386	875 / 371
Sound Pressure	Cooling	S / L / M / H	dBA	22 / 28 / 36 / 42	19 / 27 / 35 / 41	19 / 27 / 35 / 41
	Heating	L / M / H	dBA	28 / 36 / 42	27 / 35 / 41	27 / 35 / 41
Sound Power	Cooling		dBA	60	59	59
	Heating	S / L / M / H	m³ / min	2.0 / 3.0 / 6.0 / 8.0	3.0 / 4.2 / 7.5 / 10.0	3.0 / 4.2 / 7.5 / 10.0
Air Flow Rate	Max (Power)		m³ / min	10.2	12.5	12.5
	Heating	L / M / H	m³ / min	4.5 / 6.0 / 8.0	5.6 / 7.2 / 10.0	5.6 / 7.2 / 10.0
Dehumidification Rate			l/h	1.1	1.3	1.3
	Cooling	Rated	A	3.3	4.7	4.7
Running Current	Max		A	6.0	6.0	6.0
	Heating	Rated	A	4.0	4.7	4.7
Starting Current	Max		A	7.0	7.0	7.0
Power Supply	Cooling / Heating	Rated	A	3.3 / 4.0	4.7 / 4.7	4.7 / 4.7
Circuit Breaker			∅ / V / Hz	1 / 220 - 240 / 50	1 / 220 - 240 / 50	1 / 220 - 240 / 50
Power Supply Cable			A	15	15	15
Power & Transmission Cable			N x mm²	3 x 1.0	3 x 1.0	3 x 1.0
Dimension			N x mm²	4 x 1.0	4 x 1.0	4 x 1.0
Net Weight			mm	753 x 308 x 189	837 x 308 x 189	837 x 308 x 189
Fan Motor Output			kg	8.0	8.5	8.7
			W	30	30	30
OUTDOOR				S09ES UA3	S12ES UA3	S12EW UA3
Operation Range	Cooling	Min / Max	°CDB	-10 / 48	-10 / 48	-10 / 48
	Heating	Min / Max	°CDB	-10 / 24	-10 / 24	-10 / 24
Sound Pressure	Cooling	High	dBA	48	48	48
	Heating	High	dBA	50	50	50
Sound Power	Cooling	High	dBA	65	65	65
	Heating	High	m³ / min	27	27	27
Piping	Length (Odu / ldu)	Min / Max	m	3 / 15	3 / 15	3 / 15
	Elevation (Odu / ldu)	Max	m	7	7	7
Piping Connection	Liquid	OD (Outside)	mm (inch)	6.35 (1/4)	6.35 (1/4)	6.35 (1/4)
	Gas	OD (Outside)	mm (inch)	9.52 (3/8)	9.52 (3/8)	9.52 (3/8)
Drain Hose Size		OD (Outside)	mm (inch)	21.5 (0.85)	21.5 (0.85)	21.5 (0.85)
	Type			R32	R32	R32
Refrigerant	Charge at 7.5m		kg	0.670	0.700	0.700
	Additional charge		t-CO <sub>2</sub> eq	0.452	0.473	0.473
	GWP		g/m	20	20	20
Fan Motor Output			W	675	675	675
Compressor Type				30	43	43
Net Weight				Twin Rotary	Twin Rotary	Twin Rotary
Dimension			kg	26	26	26
			mm	717 x 495 x 230	717 x 495 x 230	717 x 495 x 230

\* This product contains Fluorinated greenhouse gases (R32).

\*\* S : Sleep / L : Low / M : Medium / H : High

\*\*\* GWP : Global warming potential

\*\*\*\* t-CO<sub>2</sub>eq : F-gas(kg)\*GWP/1000

\*\*\*\*\* Specification, design and feature are subject to change without prior notice.



# INDOOR UNIT

F09MT.NSM / F12MT.NSM

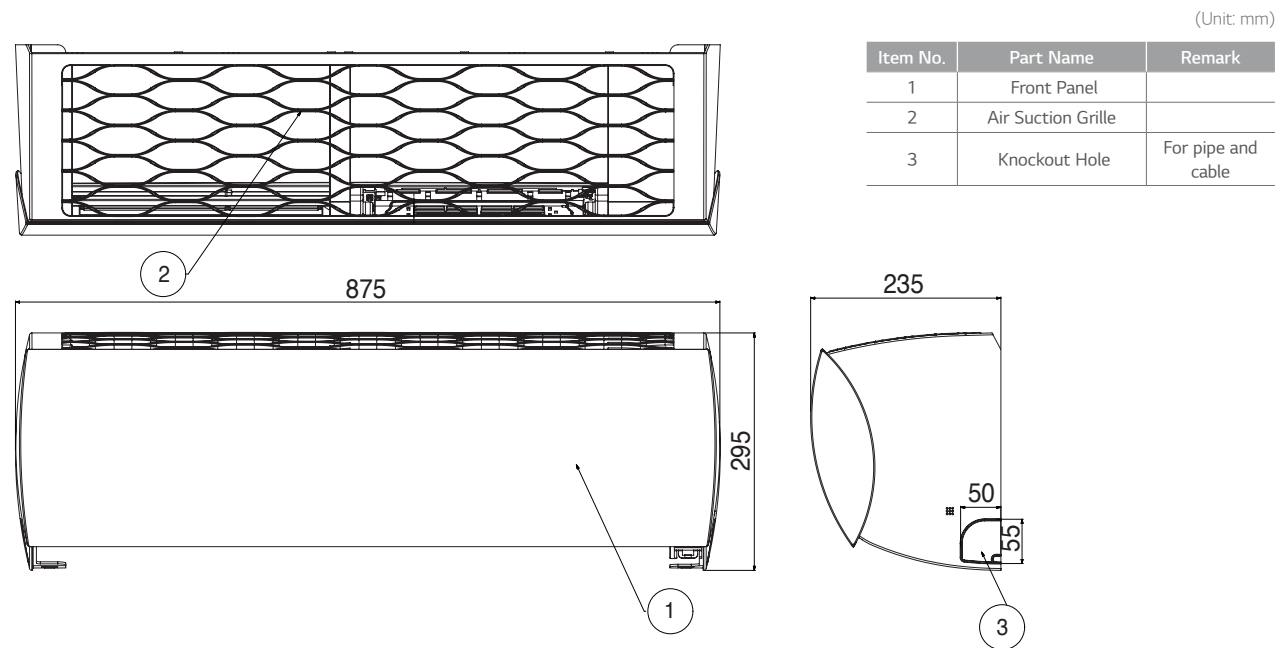

A09FT.NSF / A12FT.NSF

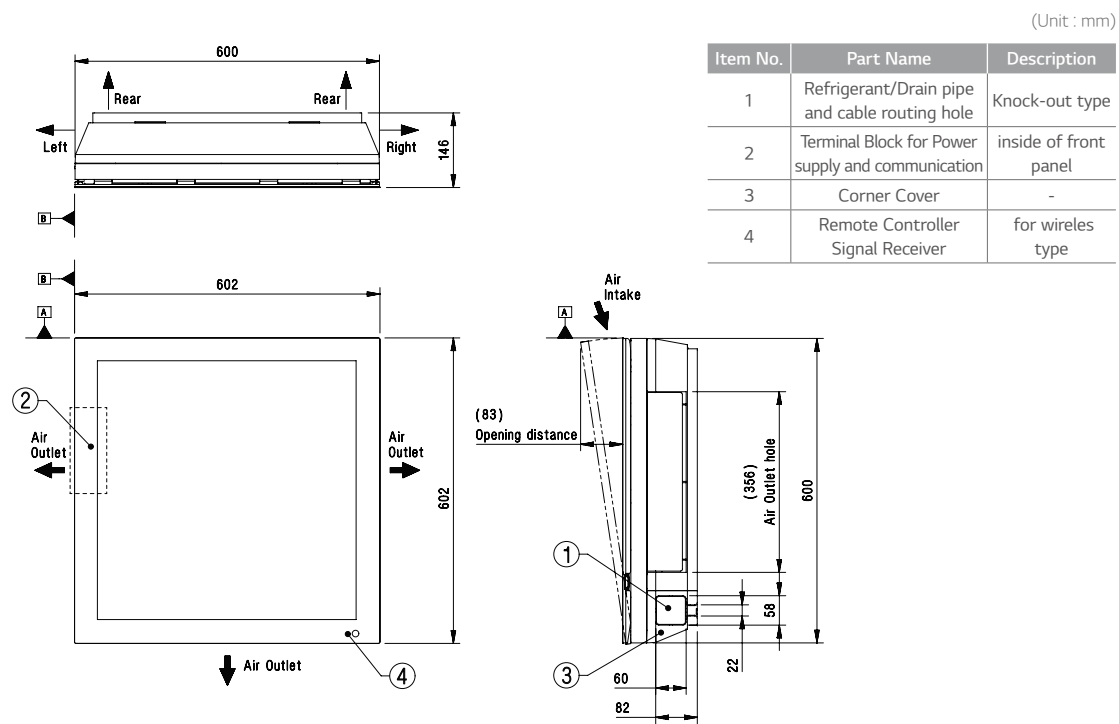

# INDOOR UNIT

AC09BQ.NSJ / AC12BQ.NSJ / AC09SQ.NSJ / AC12SQ.NSJ

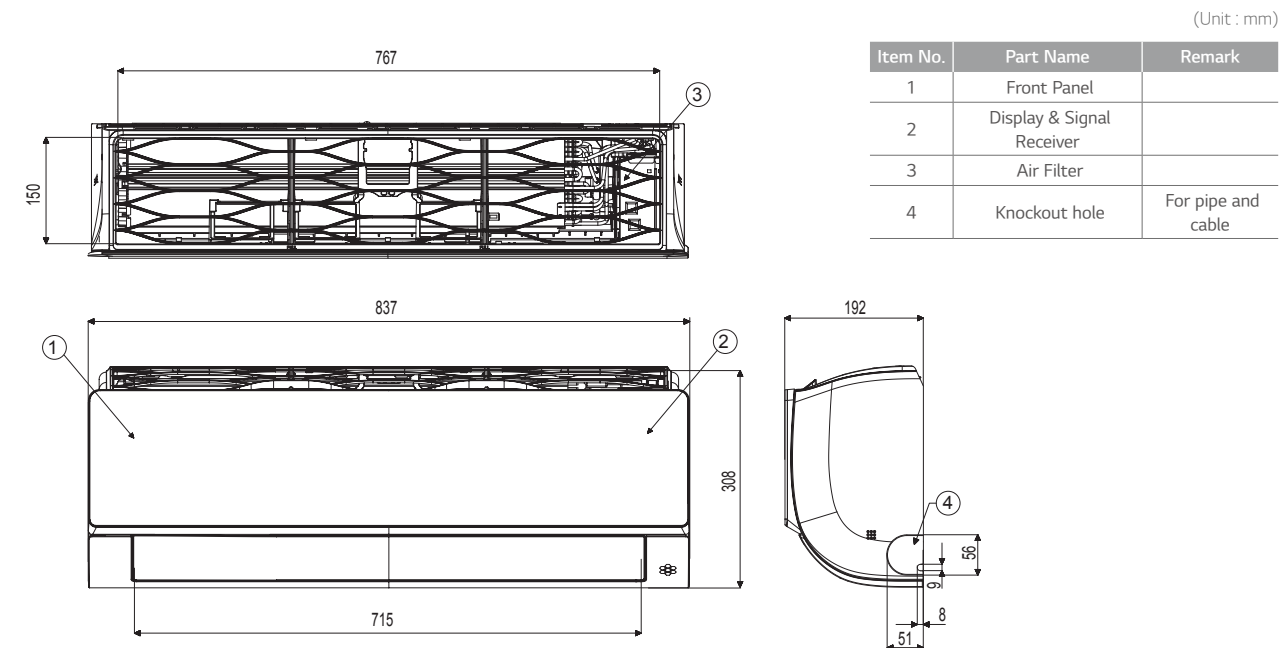

AC18BQ.NSK / AC24BQ.NSK / AC18SQ.NSK

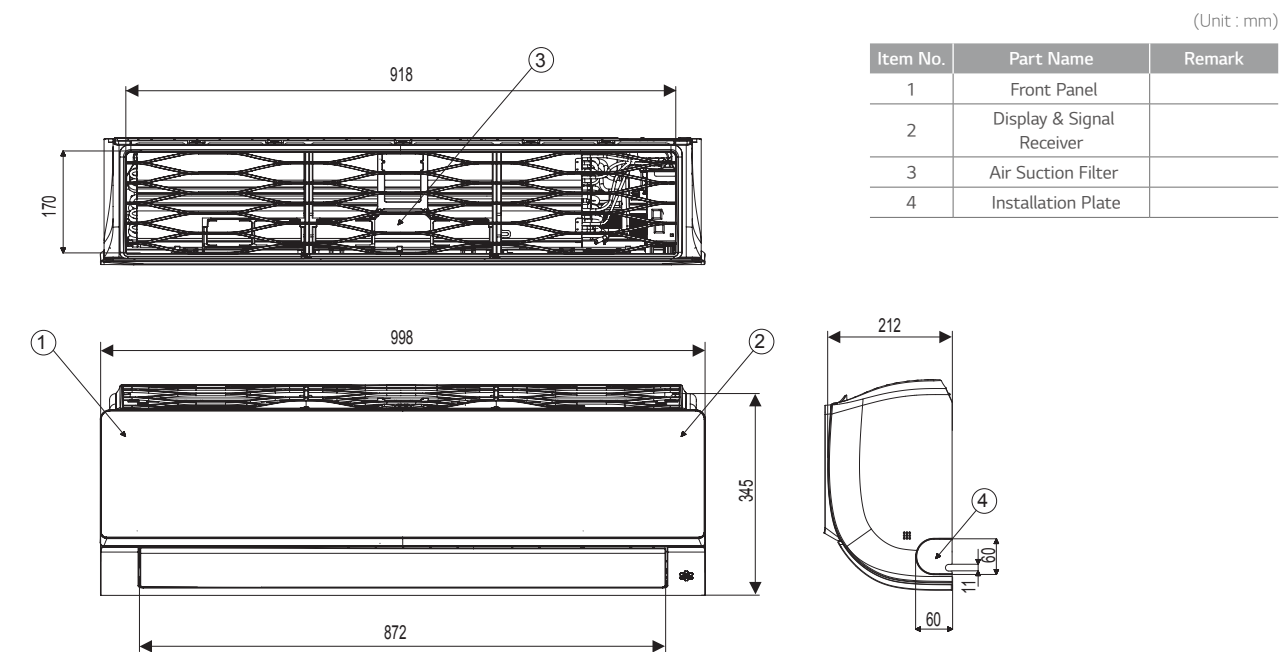

# INDOOR UNIT

DC09RQ.NSJ / DC12RQ.NSJ / DC09RT.NSJ / DC12RT.NSJ / PC09SQ.NSJ / PC12SQ.NSJ / S09EQ.NSJ / S12EQ.NSJ / S09ET.NSJ / S12ET.NSJ / S12ES.NSJ

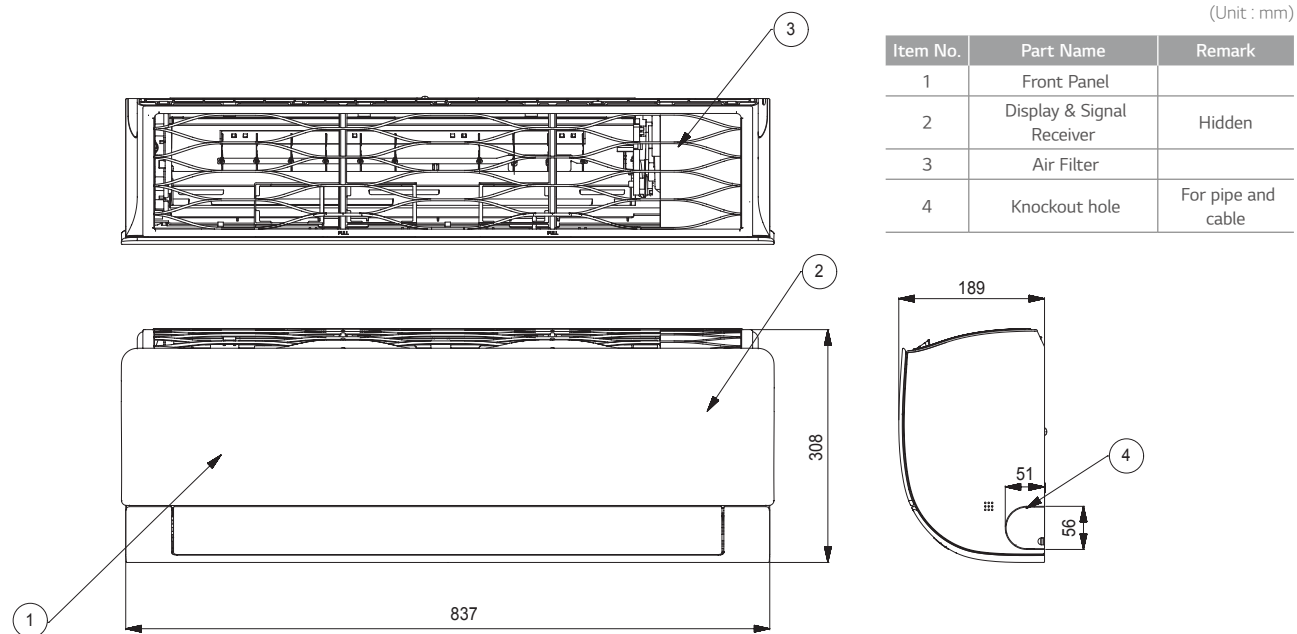

DC18RQ.NSK / DC24RQ.NSK / PC18SQ.NSK / PC24SQ.NSK / S18EQ.NSK / S24EQ.NSK / S18ET.NSK / S24ET.NSK

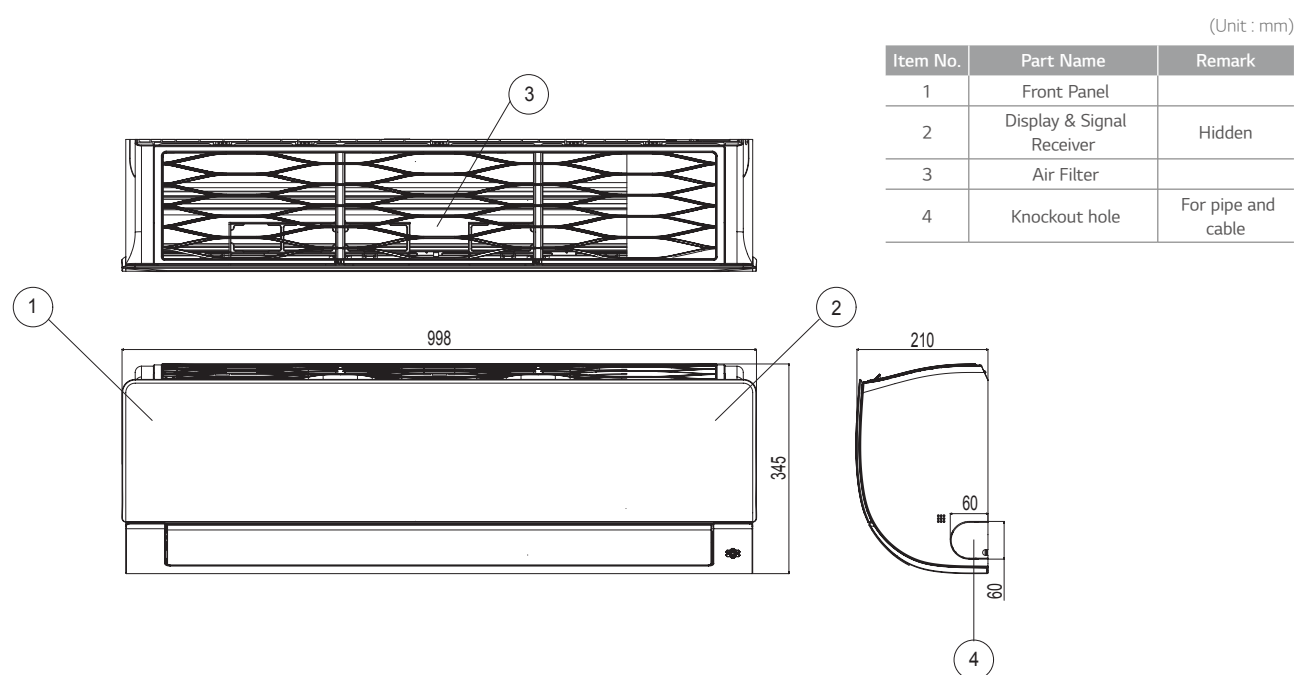

# INDOOR UNIT

S09ES NSA

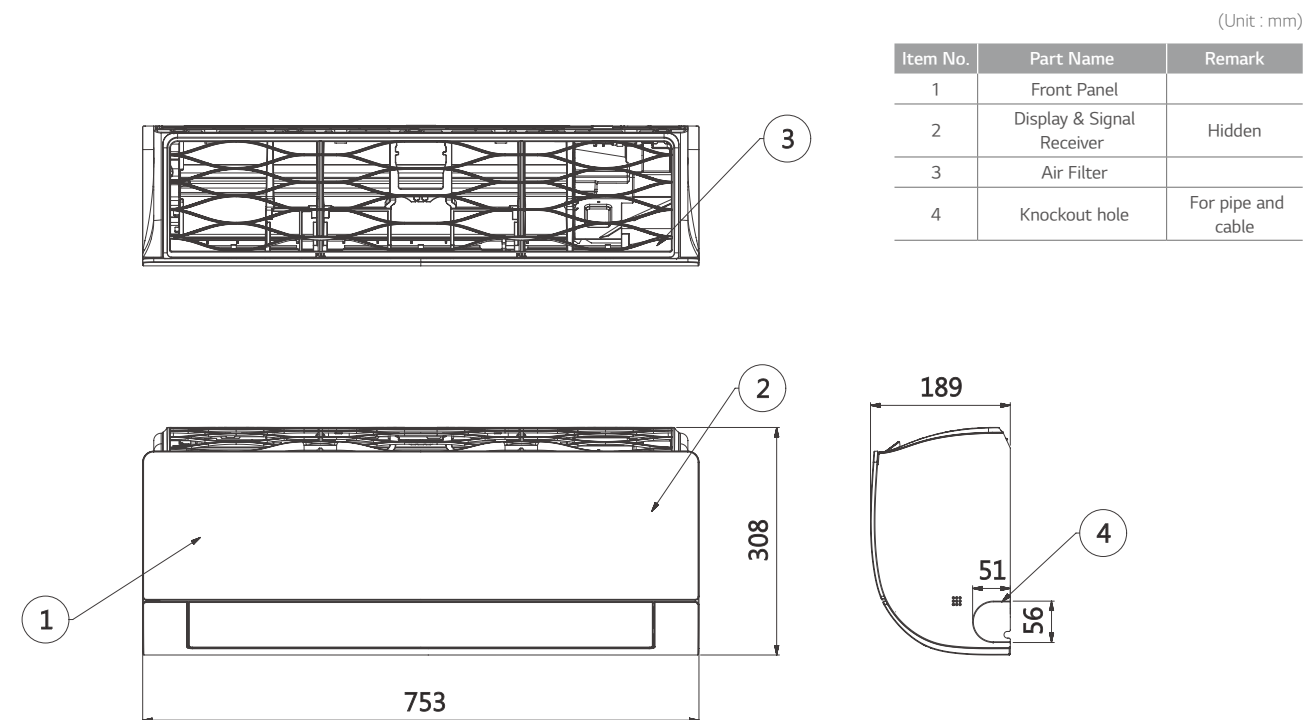

AP09RT.NSJ / AP12RT.NSJ

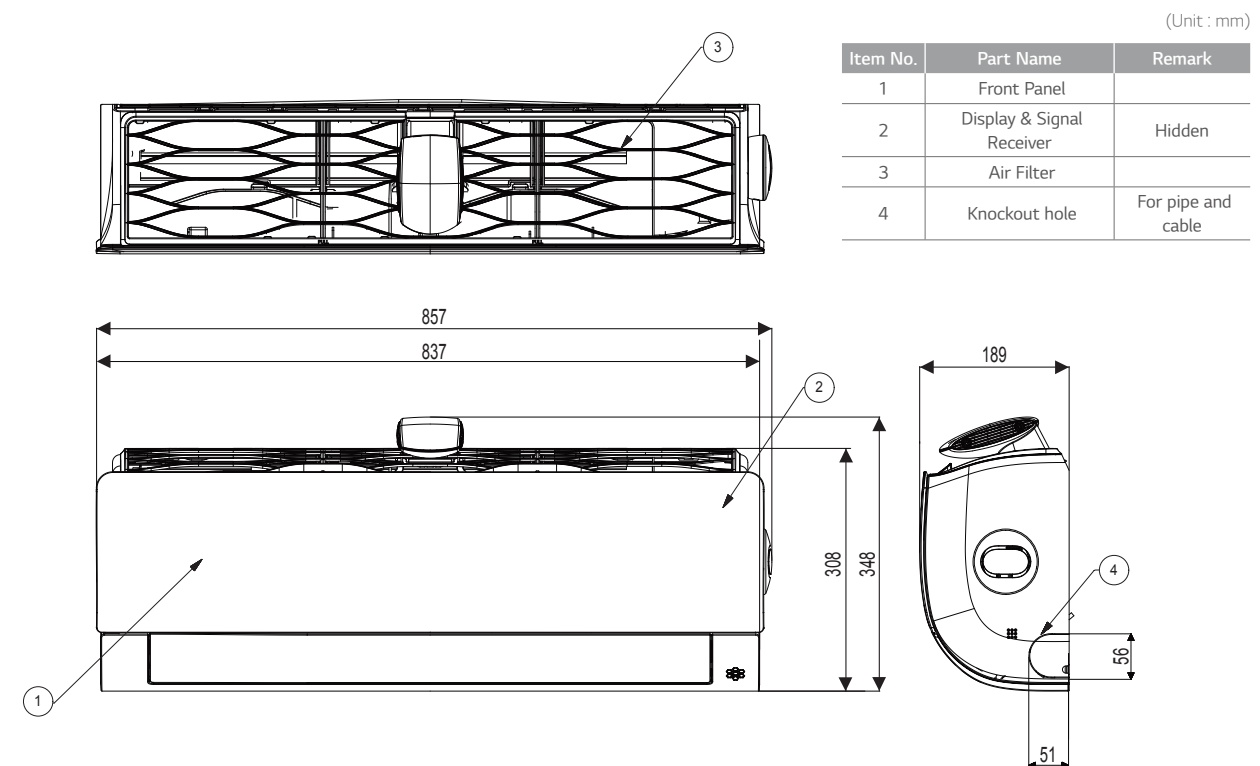

# OUTDOOR UNIT

AC09BQ.UA3 / AC12BQ.UA3 / AC09SQ.UA3 / AC12SQ.UA3 / DC09RT.UA3 / DC12RT.UA3 / PC09SQ.UA3 / PC12SQ.UA3 / S09EQ.UA3 / S12EQ.UA3 / S09ET.UA3 / S12ET.UA3 / S12ES.UA3 / AP09RT.UA3 / AP12RT.UA3 / S09ES.UA3

(Unit: mm)

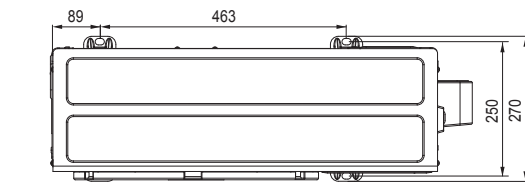

Item No.	Part Name
1	Air Outlet
2	Control Box
3	Power and Communication Cable Hole
4	Service Valve Cover
5	Gas Pipe Connection
6	Liquid Pipe Connection

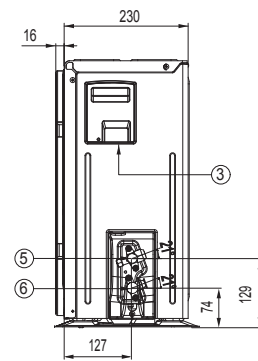
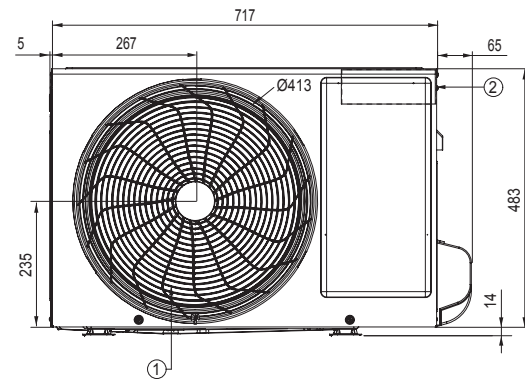

A09FT.UL2 / A12FT.UL2 / DC09RQ.UL2 / DC12RQ.UL2 / AC18BQ.UL2 / AC18SQ.UL2 / DC18RQ.UL2 / PC18SQ.UL2 / S18EQ.UL2 / S18ET.UL2 /

(Unit: mm)

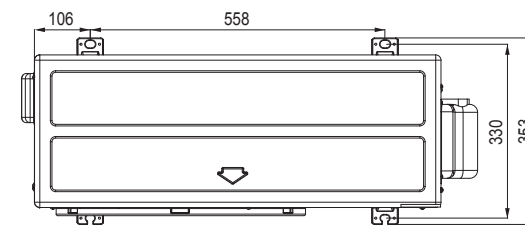

Item No.	Part Name
1	Air Outlet
2	Control Box
3	Power and Communication Cable Hole
4	Service Valve Cover
5	Gas Pipe Connection
6	Liquid Pipe Connection

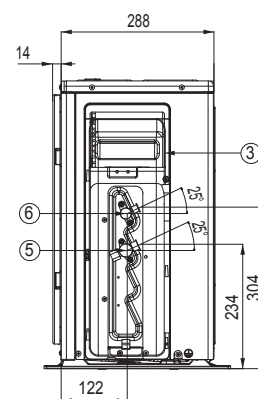
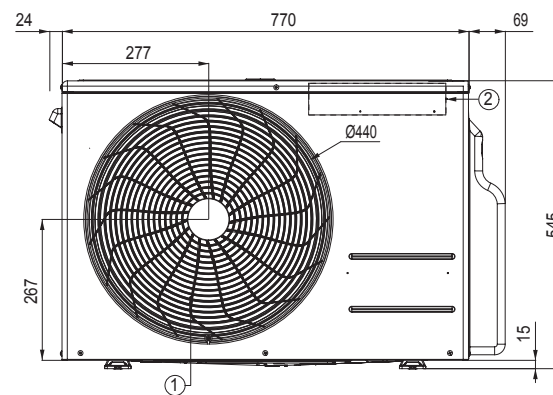

# OUTDOOR UNIT

F09MT.U24 / F12MT.U24 / AC24BQ.U24 / DC24RQ.U24 / PC24SQ.U24 / S24EQ.U24 / S24ET.U24

(Unit: mm)

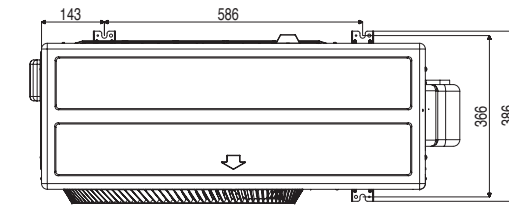

Item No.	Part Name
1	Air Outlet
2	Control Box
3	Power and Communication Cable Hole
4	Service Valve Cover
5	Gas Pipe Connection
6	Liquid Pipe Connection

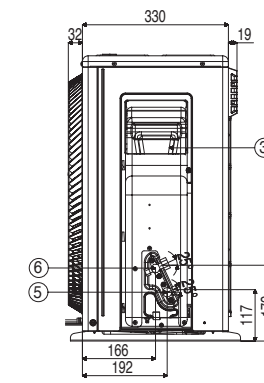
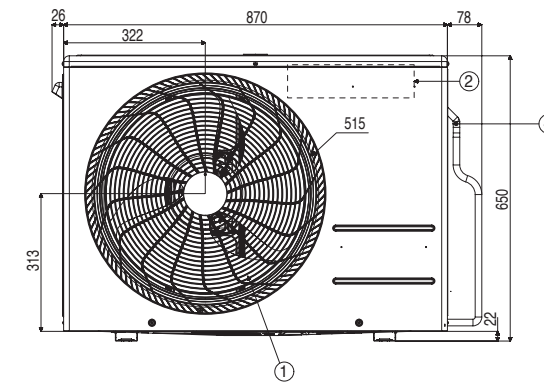

# ACCESSORIES

	ARTCOOL GALLERY	ARTCOOL	PRESTIGE	DELUXE	DELUXE2	STANDARD PLUS	STANDARD2	STANDARD	STANDARD3
Wired Remote Controller	5k					Y			
	7k		Y		Y	Y		-	-
	9k	-	Y	Y	Y	Y	Y	-	-
	12k	-	Y	Y	Y	Y	Y	-	-
	15k								
	18k		Y		Y		Y	Y	-
PI 485	5k					-			
	7k		-		Y*	-		-	-
	9k	Y	-	-	Y*	Y*	-	-	
	12k	Y	-	-	Y*	Y*	-	-	
	15k								
	18k		-		Y*		-	-	-
Dry Contact	5k					Y			
	7k		Y		Y	Y		-	-
	9k	Y	Y	Y	Y	Y	Y	-	-
	12k	Y	Y	Y	Y	Y	Y	-	-
	15k								
	18k		Y		Y		Y	Y	-
24k		Y		Y		Y	Y	-	

\* Y: Available  
 \* When connected to Multi 14k & 16k Outdoor units, this may not be supported.

## Standard Wired Remote Control



MODEL NAME	PREMTB100 PREMTBB10	PREMTB001 PREMTBB01
Operation Mode	On/Off, Fan Speed Control, Temperature Setting	
Mode Change	Cooling / Heating / Auto / Dehumidification / Fan	
Auto Swing / Vane Control	•	
Reservation	Simple / Sleep / On, Off / Weekly / Holiday	
Time Display	•	
Electrical Failure Compensation	•	
Child Lock	•	
Operation Status LED	•	
Indoor Temperature Display	•	
Wireless Remote Controller Receiver	-	
Size (W x H x D, mm)	120 x 120 x 16	120 x 121 x 16
Backlight	•	
Display AirQuality Status	-	

※ Refer to each model PDB for applicable models.

## PI 485



PMNFP14A1

Power : Single phase AC 220V 50/60Hz  
 Max. no of the indoor units that can be connected: 64 UNITS  
 Model applied : RAC / Multi / Single / Therma V  
 ※ Refer to each product PDB for applicable models

# ACCESSORIES

## Dry Contact

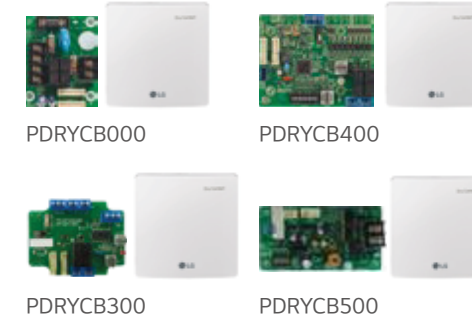

※ Refer to each product PDB for applicable models

MODEL	PDRYCB000	PDRYCB400	PDRYCB300	PDRYCB500
Contact Point	1 Control Point	2 Control Point	8 Control Point	Modbus RTU
Power Input	AC 220V from outside power source	DC 5V & 12V from indoor unit PCB	DC 5V & 12V from indoor unit PCB	DC 5V & 12V from indoor unit PDB
Voltage / Non Voltage Input		•	•	
On / Off Control	•	•	•	•
Lock / Unlock	•	•	•	
Fan Speed Setting			•	•
Thermo Off		•	•	
Energy Saving		•		
Temperature Setting		•	•	•
Error Monitoring	•	•	•	•
Operation Monitoring	•	•	•	•

## Remote Control



Prestige  
 Artcool  
 Deluxe, Deluxe2,  
 Standard Plus  
 Standard, Standard2, Standard3

BUTTON	DISPLAY SCREEN	DESCRIPTION
	-	To turn On / Off the air conditioner.
	88°	To adjust the desired room temperature in cooling, heating or auto changeover mode.
COMFORT AIR		To adjust the air flow to deflect wind.
LIGHT OFF	-	To set the brightness of the display on the indoor unit.
MODE		To select the cooling mode.
		To select the heating mode.
		To select the dehumidification mode.
		To select the fan mode.
		To select the auto changeover / auto operation mode.
FAN SPEED		To adjust the fan speed.
ENERGY CTRL.		To bring the effect of the power saving.
JET MODE		To change room temperature quickly.
		To adjust the air flow direction vertically or horizontally.
ROOM TEMP		To display the room temperature.
°C ↔ °F[5sec]		To change unit between °C and °F.
SET/CANCEL	-	To set / cancel the functions and timer.
	-	To adjust time.
	-	To turn on / off air conditioner automatically.
	-	To cancel the timer settings.

# MULTI SPLIT



# LINE - UP

## R32 INDOOR / OUTDOOR UNIT

○ Single Only ○● Compatible ● Multi Only

KBTU/H		5	7	9	12	15	18	24
KW		1.5	2.1	2.6	3.5	4.2	5.3	7.0
Wall Mounted Unit	ARTCOOL Gallery			●	●			
	ARTCOOL Mirror		●	○●	○●		○●	○●
	ARTCOOL Silver			○●	○●		○●	
	Air - Purifying			○●	○●			
	Deluxe		●	○●	○●		○●	○●
	Standard Plus	●	●	○●	○●	●	○●	○●
	Standard 2	●		○●	○●		○●	○●
Ceiling Mounted Cassette	1 Way Cassette			●	●			
	4 Way Cassette	●	●	○●	○●		○●	○●
Ceiling Concealed Duct	Mid / High Static Pressure						○●	○●
	Low Static Pressure			○●	○●		○●	○●
KBTU/H		14	16	18	21	24	27	30
KW		4.1	4.7	5.3	6.2	7.0	7.9	8.8
Multi		●	●	●	●	●	●	●

## R410A INDOOR / OUTDOOR UNIT

KBTU/H		5	7	9	12	15	18	24
KW		1.5	2.1	2.6	3.5	4.2	5.3	7.0
Ceiling & Floor Convertible				●	●			
Console				●	●		●	
KBTU/H		40		48		56		
KW		11.7		14.1		16.4		
Multi	Multi Piping	●	●	●	●	●	●	●
	Distribution Box	●	●	●	●	●	●	●

# FEATURE OVERVIEW

Refrigerant	R32							R410A			
	MULTI PIPING							DB BOX TYPE			
Type	14	16	18	21	24	27	30	40	40	48	56
kBtu/h											
kW											
BLDC Comp. & Fan Motor	●	●	●	●	●	●	●	●	●	●	●
Eurovent Certification	●	●	●	●	●	●	●	●	●	●	●
Variable Voltage Control			●	●	●	●	●	●	●	●	●
Wide Louver Plus Fin	●	●	●	●	●	●	●	●	●	●	●
Optimized Heat Exchanger Path	●	●	●	●	●	●	●	●	●	●	●
Power Saving Start up			●	●	●	●	●	●	●	●	●
Peak Current Control	●	●	●	●	●	●	●	●	●	●	●
Standby Mode	●	●	●	●	●	●	●	●	●	●	●
Mode Lock	●	●	●	●	●	●	●	●	●	●	●
R1 Compressor								●	●	●	●
Twin Rotary Compressor	●	●	●	●	●	●	●	●	●	●	●
Smart Sensor Pressure Control			●	●	●	●	●	●	●	●	●
Black Fin Heat Exchanger	●	●	●	●	●	●	●	●	●	●	●
Fast Cooling & Heating			●	●	●	●	●	●	●	●	●
Night Silent Operation	●	●	●	●	●	●	●	●	●	●	●
Wiring Error Check	●	●	●	●	●	●	●	●	●	●	●
LG MV	●	●	●	●	●	●	●	●	●	●	●
PI-485 Connection			●	●	●	●	●	●	●	●	●
Forced Cooling Operation	●	●	●	●	●	●	●	●	●	●	●

# KEY FEATURES

## PERFECT SOLUTION FOR MULTIPLE ROOMS



**Energy Efficiency | Extreme Durability | Comfort and Convenience**

LG's Multi Split system provides powerful, efficient cooling and heating with two, three, four, or up to nine indoor units operating from a single outdoor unit. LG's advanced inverter technology offers powerful performance while consuming less energy and floor space than that of individual single split systems.



# ENERGY EFFICIENCY

## ENERGY EFFICIENCY A+++ / A+

The advanced technologies of LG achieve the lowest energy consumption, especially SEER value regarding ErP regulation.

World Class High Efficiency

SEER 8.5

SEER / SCOP class (ErP regulation)

kW	4.1	4.7	5.3	6.2	7.0	7.9	8.8
SEER	8.5	7.8	8.5	8.5	8.0	8.0	8.2
	A+++	A++	A+++	A+++	A++	A++	A++
SCOP	4.2	4.2	4.4	4.4	4.4	4.2	4.2
	A+	A+	A+	A+	A+	A+	A+

- BLDC Inverter Twin Rotary Compressor
- Enhanced Heat Exchanger
- Smart Load Control
- Peak current control



## Powerful Brushless Direct Current Motor (BLDC) Compressor

LG air conditioners are equipped with a BLDC Inverter Twin Rotary Compressor that uses a neodymium magnetic core. The compressor has high efficiency and superior reliability, because it is excellent in controlling the operating speed depending on the load. With improved efficiency as compared to standard AC inverter products, this compressor is optimized for outdoor load changes and seasonal efficiency.

### • Operation Range

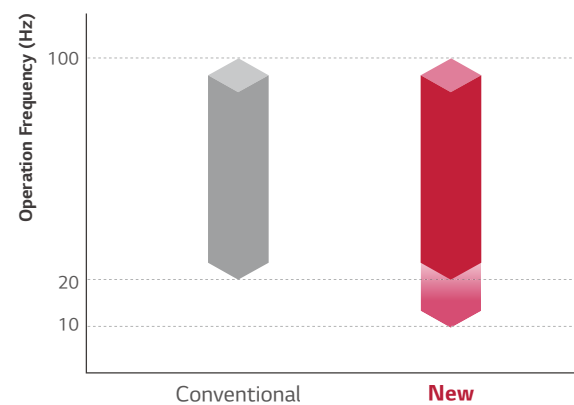

### • Motor Efficiency

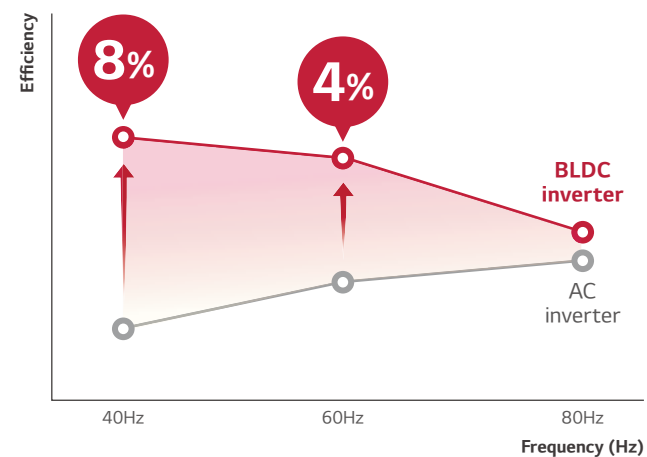

# ENERGY EFFICIENCY

## Enhanced Heat Exchange

Wide Louver Plus fin technology increases 11% of full load heating performance and 6% of COP compared to conventional fin. It can slow down frosting of heat exchanger and postpone the start of defrosting operation.

### • Heating Operation at Defrost Condition

It can slow down frosting of heat exchanger and postpone the start of defrosting operation

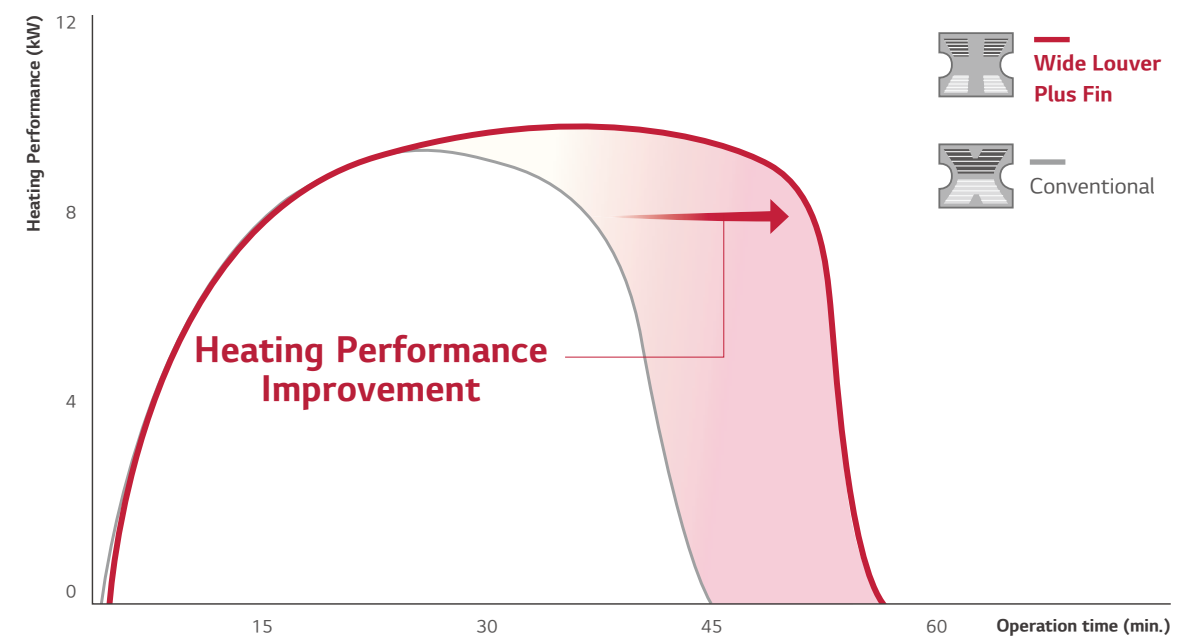
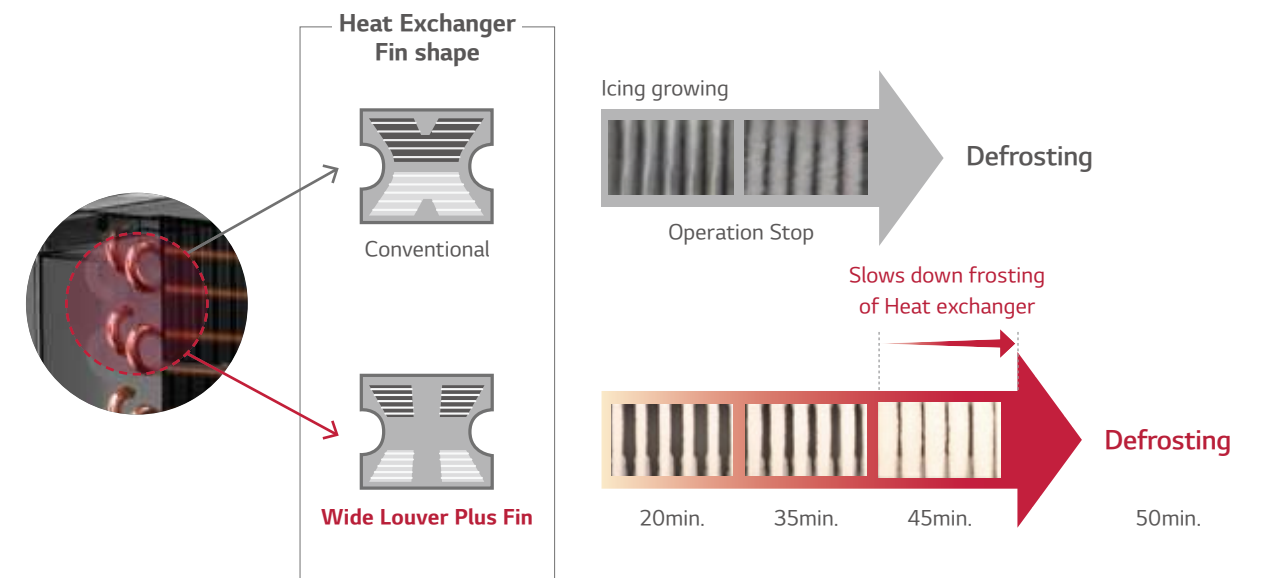

\* LG Internal test data



# ENERGY EFFICIENCY

## Power Saving Start Up

LG commercial air conditioners will automatically alter the temperature of discharge air by controlling their refrigerant temperature based on the difference between the indoor temperature and the target indoor temperature. During cooling operation, evaporating temperature will increase if the temperature difference reduces. This allows for enhanced comfort and reduced energy consumption.

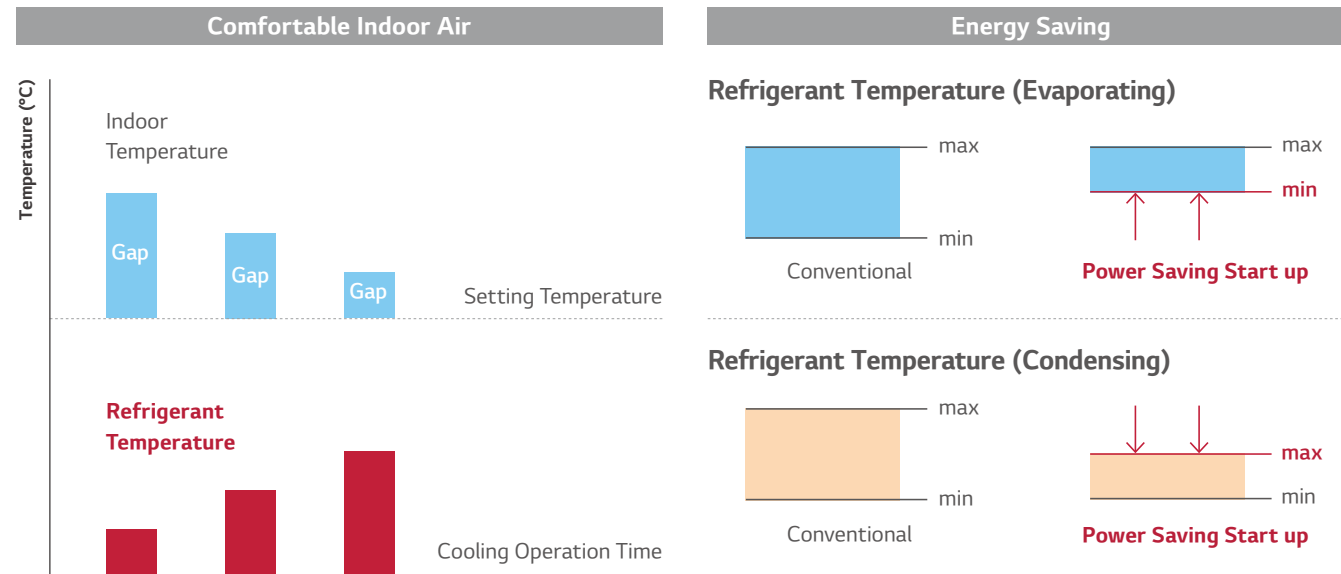

## Mode Lock

Set the operation mode to either cooling-only or heating-only; either by adjusting the wired remote controller or setting the DIP switch to avoid combined use of cooling and heating. (Some models need wired remote controller for mode lock function according to feature overview table)

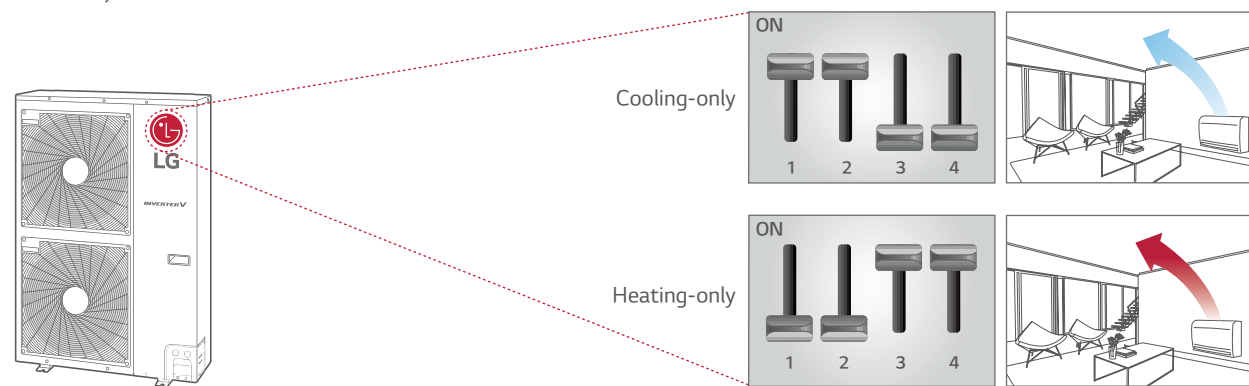

# ENERGY EFFICIENCY

## Peak Current Control

The peak current control function keeps the air conditioner from running at the maximum level while maintaining current system setting, in order to reduce energy consumption. This function allows for reduced energy costs during the peak energy use periods when energy fees are higher.

### • How to set dip switch

#### STEP 1

Max power consumption : 1.9 kW

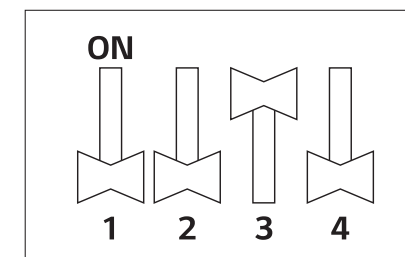

\* Full Load consumption : 2.5kW  
\* 7.0kW model  
\* LG Internal test result

#### STEP 2

Max power consumption : 1.7 kW

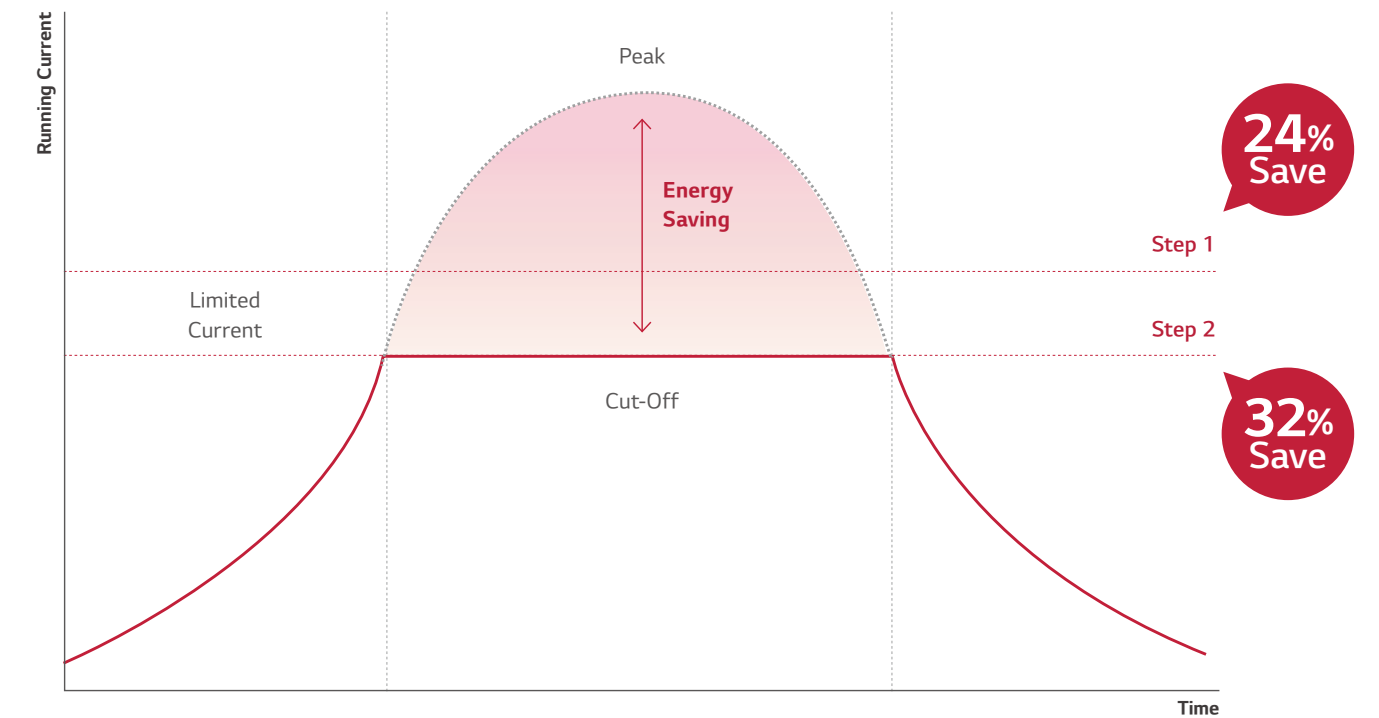
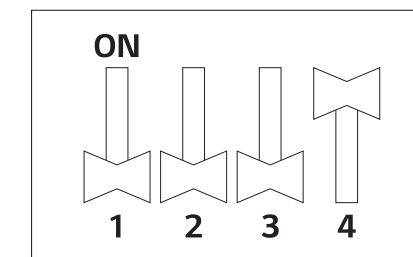

\* When using Peak current control, the cooling capacity may not be sufficient.  
\* 7.0kW model  
\* LG Internal test result

# EXTREME DURABILITY

Product durability is attested by a 10-year compressor warranty.



**INVERTER COMPRESSOR**  
**10 YEAR WARRANTY**

## Product Safety & Durability Reassured

- Improved BLDC Inverter Twin Rotary compressor
- Smart Sensor
- Black Fin Heat Exchanger

## Improved BLDC Inverter Twin Rotary Compressor

Parts of BLDC Inverter Twin Rotary Compressor have been improved to allow a longer life span.

**Flow Optimization**  
Reduced oil inflow by increasing the length of oil discharge pipe, leading to a sufficient oil quantity inside compressor hence preventing compressor abrasion.

**Concentrated Winding Motor**  
- Oil path area is improved by over 50% by increasing the extra stator cavity.  
- Due to this, caloric value of motor is reduced, improving the cooling function of stator coil.

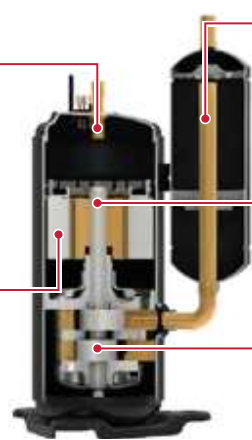

**Twin Rotary Inverter Compressor**

**Suction Optimization**  
Reduced suction loss and improving oil collection through the optimization of suction path.

**Surface Coating**  
Shaft coating and polishing has been improved.

**Twin Rotary Rotor**  
- Upper and lower part rotor offset imbalance in shaft rotor rotation. Max Torque has been decreased by 45% compared to single rotor.  
- Vibration and noise is also reduced.

# EXTREME DURABILITY

## Pressure Control Technology by Smart Sensor

Quicker and more reliable operation made possible by pressure control technology.

### • Field Failure Rate of Outdoor Unit

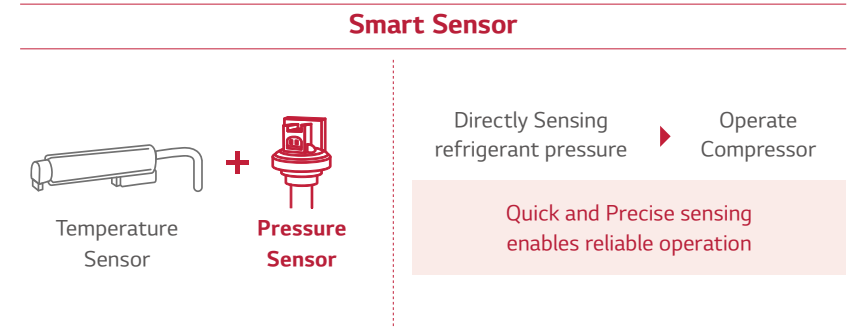
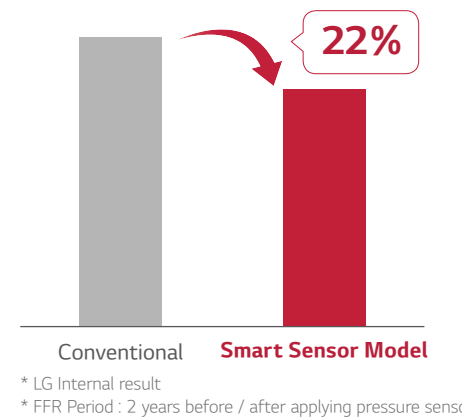

## Black Fin Heat Exchanger

The black coating with enhanced epoxy resin is applied for strong protection from various corrosive external conditions such as salt contamination and air pollution including fumes from factories. Moreover, the hydrophilic film keeps water from accumulating on the heat exchanger's fin, minimizing moisture buildup and eventually making it even more corrosion resistant.

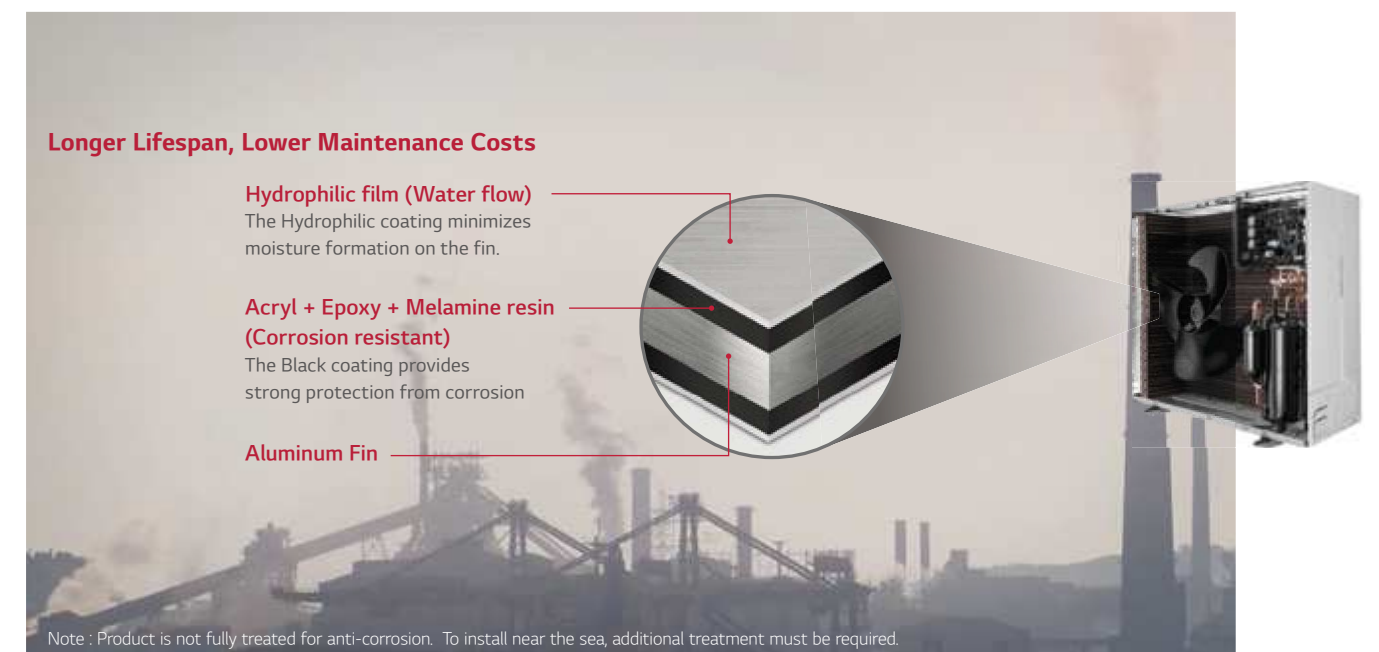

# EXTREME DURABILITY

## R1 Compressor

**Shaft-through Structure & Support both ends of shaft**

- Solid compressor operation assuring higher durability

**Extended Operation Range (max 150Hz)**

- Higher Heating Performance

**Centrifugal oil return & Oil separating guide for oil discharge reduction**

- Higher Energy Efficiency (\*SEER 20% ↑)

**Bottom Compression & Simple Structure**

- Lower Noise & Vibration (\*\*max 4dB(A) ↓)
- Less Weight (\*\*20% ↓)
- Superior Reliability

R1 Compressor™

\* LG Internal test result, Based on single split 10 kW Cassette  
 \*\* LG Internal test result, Based on conventional compressor (Rotary type GPT442M)  
 ※ R1 Compressor application  
 Model : 40-56k (7 models)

# EXTREME DURABILITY

## Revolutionary Scroll Compressor

Revolutionary Scroll Compressor is applied for high-efficiency and reliability. This type of compressor is more advanced compared to the conventional one. especially tilting motion of scroll has been improved. Further, the operation range is improved compared to the conventional type.

- Scroll compressor with simple structure
- High efficiency (low load at low speed / total efficiency)
- Low noise (high speed possible)
- Improved Tilting Motion of scroll
- 20% weight reduction (vs. conventional compressor)

※ Applied Model : 40-56k (7 models)

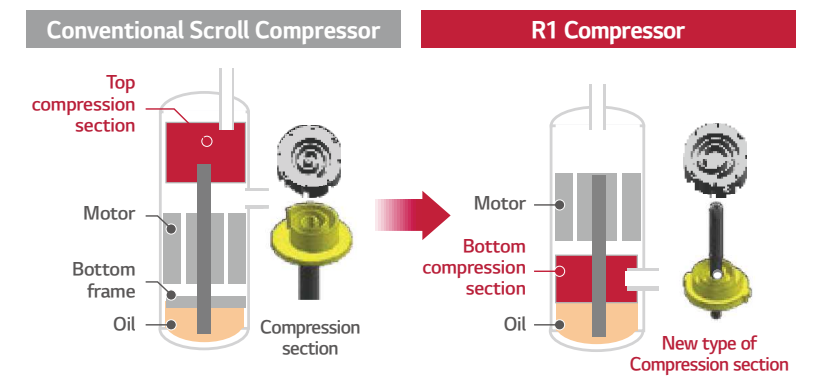

### • Seasonal energy efficiency

SEER 20%, SCOP 13% improvement (vs. rotary)  
 ※ Multi 40k

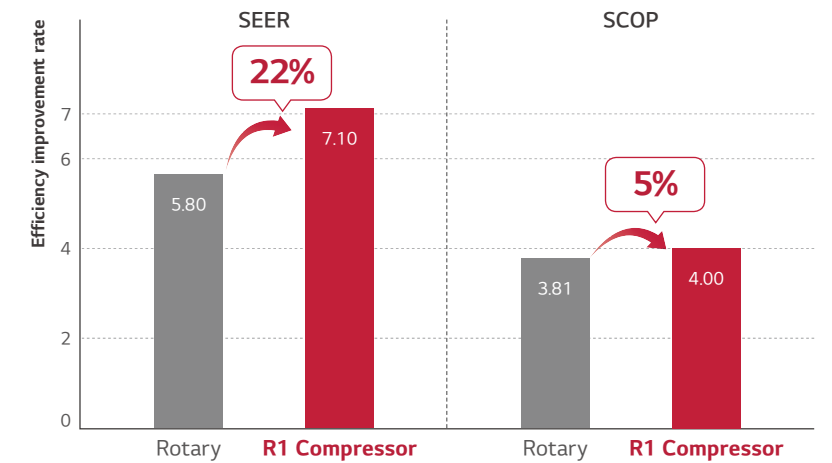

### • Wide Operation Range

- Optimized for various cooling & heat load operation
- World best compressor speed (up to 150 Hz)
- Optimized for even low load operation (down to 10 Hz)  
 (Efficiency increases / Improved comfort)

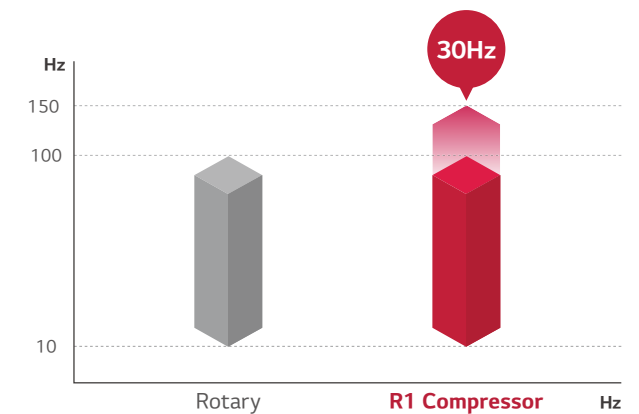

## COMFORT AND CONVENIENCE

LG air conditioners are designed to provide users with maximum levels of comfort and professionals with easy, efficient installation capabilities.



- Fast cooling and heating
- Night Silent operation
- Easy installation and maintenance

## Fast Cooling & Heating

Pressure control takes less time to reach the desired temperature up to 30% in cooling and 44% in heating with high level of accuracy and stability.

### • Cooling

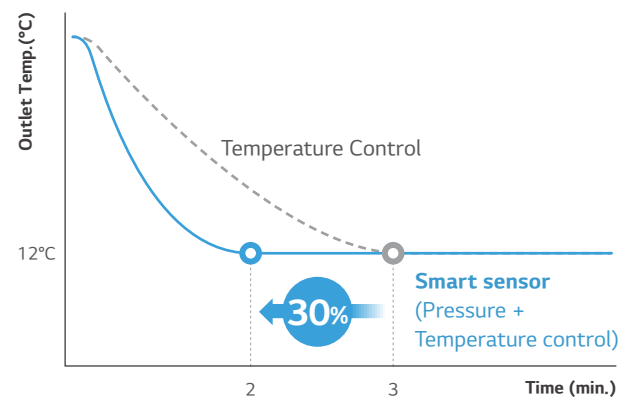

\* LG Internal test result

### • Heating

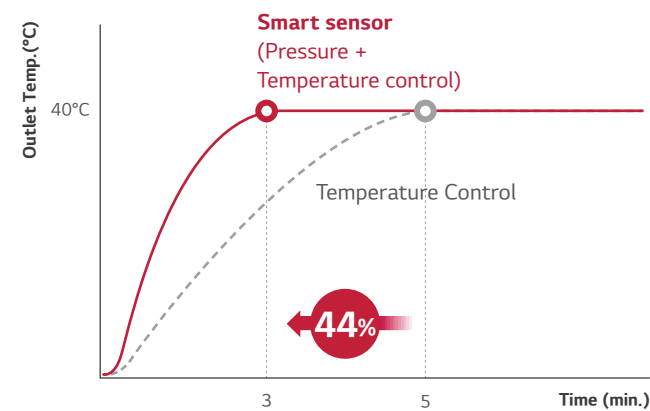

## COMFORT AND CONVENIENCE

### Night Silent Operation

Night Silent Operation can reduce noise levels at night time by simply setting the dip switch on the PCB of the outdoor unit.

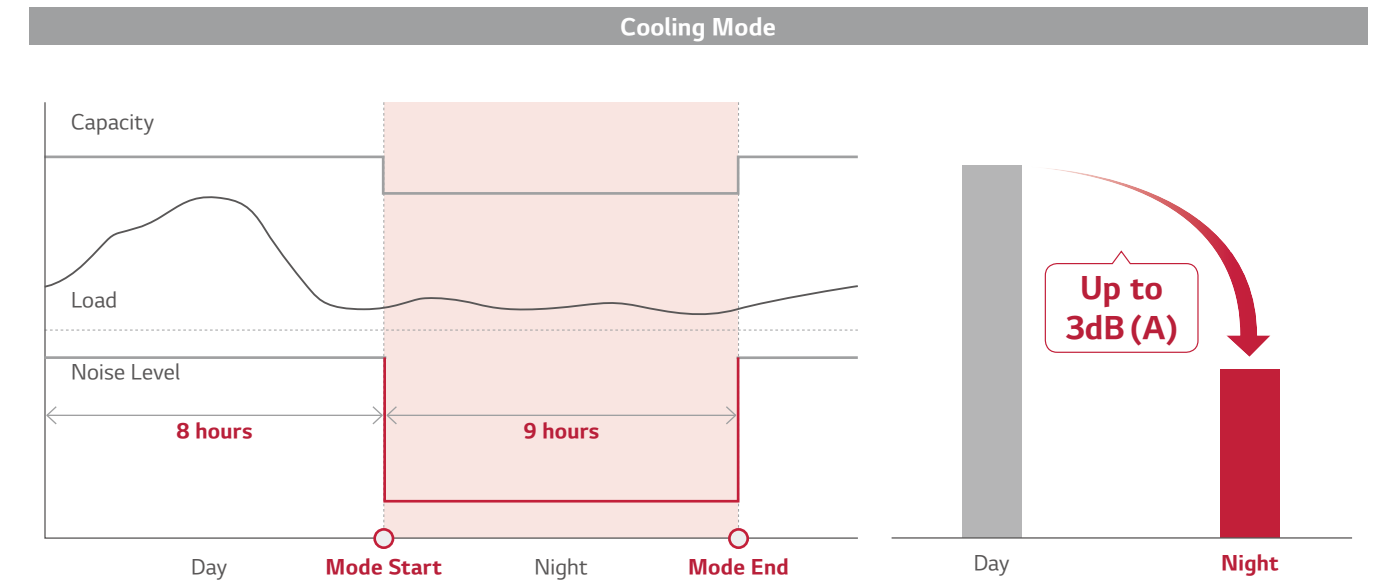

\* This function is only available for Cooling Mode.  
\* If you want to stop the Night Quiet Mode, Change the Dip Switch.

## Wiring Error Check

Installers can check whether the transmission cable has been connected correctly by using the wiring error check function. The wiring error check function can reduce the time taken to check for transmission cable errors.

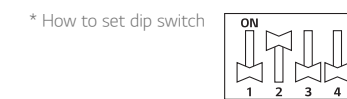
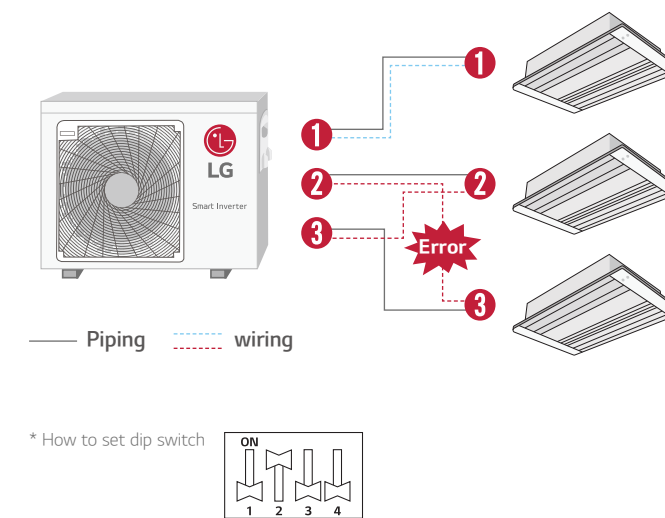

### • LED Result

- If the wiring is correct, the Green LED will light up.
- If the wiring is wrong, display as below
  - Red LED : Piping Number
  - Green LED : Wiring Number (Room)

Ex) If the Red LED blinks twice and the Green LED blinks 3 times, 2nd pipe is connected to 3rd room

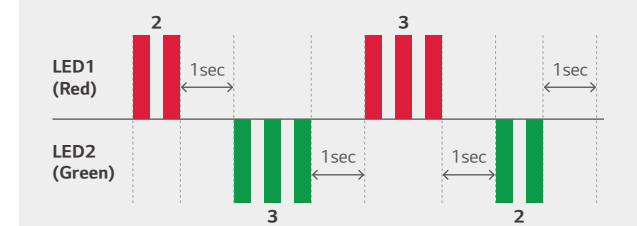

# QUIET OPERATION

## Advanced Grille & Fan

The improved grille shape design on the outdoor unit helps to distribute air more efficiently which improves heat exchange and reduces the noise level. The new axial Fan has a thick front edge and a smooth rear edge, thus providing not only high efficiency, low noise, wide fan, but also improving the air flow rate.

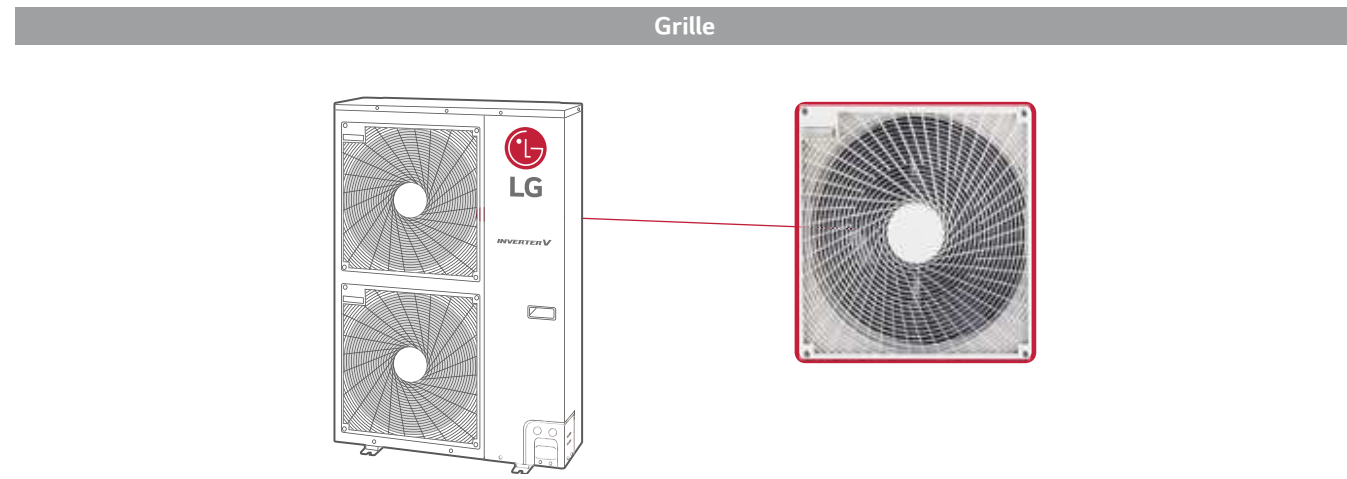

### Fan Type 1

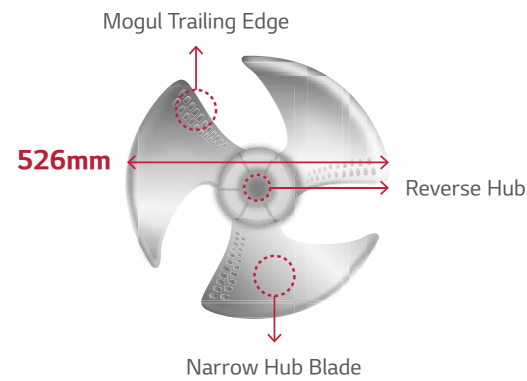

### Fan Type 2

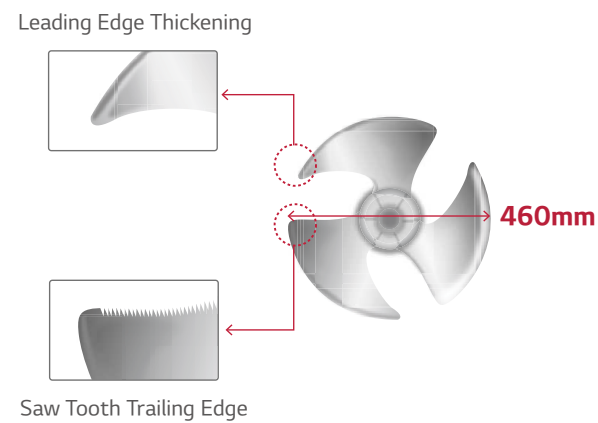

# COMFORT AND CONVENIENCE

## LG MV (Monitoring View)

LG MV helps engineers to inspect and monitor air conditioning units easily.

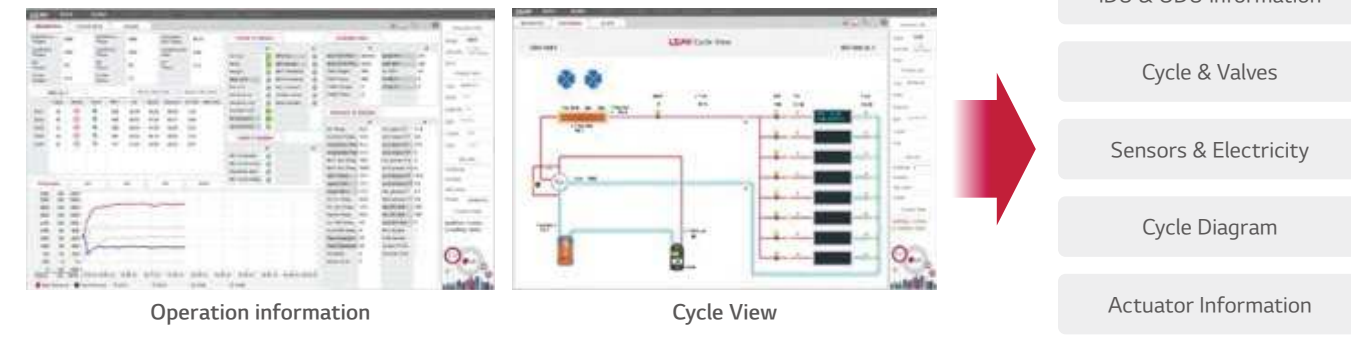
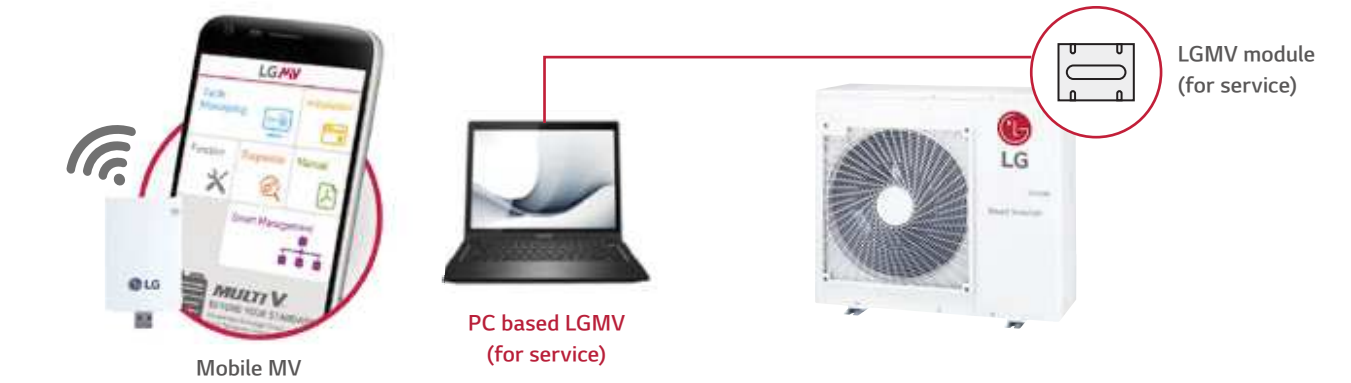

## Forced Cooling Operation

The forced cooling operation allows refrigerant to be recharged or pumped down, regardless of the indoor temperature. More importantly this function can be used when indoor units are being moved or repaired.

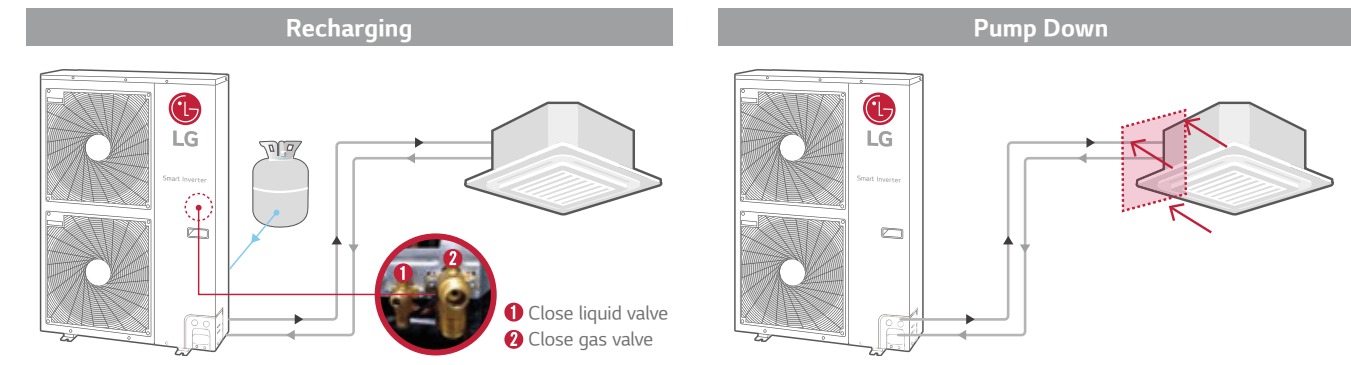

# R32 MULTI SPLIT



R32 MULTI SPLIT

## OUTDOOR UNITS



RESIDENTIAL  
MULTI SPLIT

MU2R15  
MU2R17

(Unit : mm)



LG participates in the ECP programme for EUROVENT AC program.  
Check ongoing validity of certification  
: [www.eurovent-certification.com](http://www.eurovent-certification.com)

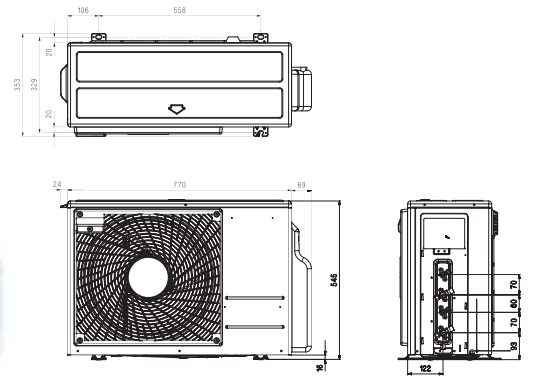

OUTDOOR UNIT				MU2R15.ULO	MU2R17.ULO	
Compressor	Type			Twin Rotary	Twin Rotary	
Capacity *	Cooling	Min / Nom / Max	kW	0.9 / 4.1 / 4.7	0.9 / 4.7 / 5.4	
	Heating	Min / Nom / Max	kW	1.0 / 4.7 / 5.4	1.0 / 5.3 / 5.7	
Low Temperature Capacity	Heating -7°C	Max	kW	3.3	3.7	
Power Input *	Cooling	Min / Nom / Max	kW	0.2 / 1.0 / 1.4	0.2 / 1.3 / 1.7	
	Heating	Min / Nom / Max	kW	0.2 / 1.1 / 1.4	0.2 / 1.3 / 1.6	
Running Current	Cooling	Min / Nom / Max	A	1.1 / 4.6 / 6.4	1.1 / 5.6 / 7.9	
	Heating	Min / Nom / Max	A	1.1 / 4.9 / 6.6	1.1 / 5.5 / 7.6	
EER				4.14	3.75	
COP				4.38	4.22	
SEER				8.50	7.80	
SCOP				4.20	4.20	
Pdesign (@-10°C)			kW	4.10	4.10	
Seasonal Energy Label	Cooling / Heating (A+++ to D Scale)			A+++ / A+	A++ / A+	
Annual Energy Consumption	Cooling / Heating			169 / 1,367	210 / 1,367	
Airflow Rate	Nom		m <sup>3</sup> /min	28.2	28.2	
Sound Pressure	Cooling	Nom	dB(A)	48	48	
	Heating	Nom	dB(A)	51	51	
Sound Power	Cooling	Max	dB(A)	61	63	
Dimensions	W x H x D		mm	770 x 545 x 288	770 x 545 x 288	
Net Weight			Kg	36	36	
Refrigerant	Type			R32	R32	
	Charge		Kg	1.1	1.1	
	Additional Charge		g/m	20	20	
	GWP				675	675
	t-CO <sub>2</sub> eq				0.74	0.74
Operation Range (Outdoor)	Cooling	Min / Max	°C DB	-10 / 48	-10 / 48	
	Heating	Min / Max	°C WB	-18 / 18	-18 / 18	
Power Supply			V, Ø, Hz	220-240, 1, 50	220-240, 1, 50	
Power Supply Cable			No. x mm <sup>2</sup>	3C x 2.5	3C x 2.5	
Transmission Cable			No. x mm <sup>2</sup>	4C x 0.75	4C x 0.75	
Circuit Breaker			A	15	15	
Piping Length Total			m	30	30	
Piping Length per Branch		Max	m	20	20	
Piping Elevation Difference	IDU - ODU	Max	m	15	15	
	IDU - IDU	Max	m	7.5	7.5	
Piping Connection	Liquid		mm(inch) x No.	Ø6.35 (1/4) x 2	Ø6.35 (1/4) x 2	
	Gas		mm(inch) x No.	Ø9.52 (3/8) x 2	Ø9.52 (3/8) x 2	

Notes :

1. Capacities are based on the following conditions:

Cooling : - Indoor Temperature 27°C (80.6°F) DB / 19°C (66.2°F) WB - Outdoor Temperature 35°C (95°F) DB / 24°C (75.2°F) WB

Heating : - Indoor Temperature 20°C (68°F) DB / 15°C (59°F) WB - Outdoor Temperature 7°C (44.6°F) DB / 6°C (42.8°F) WB

Piping Length - Interconnecting Piping Length 7.5m - Level Difference of Zero.

2. \* : See page "Combination Table".

3. Due to our policy of innovation some specifications may be changed without notification.

4. At least two indoor units should be connected

5. Minimum combination ratio should be more than 40%

6. This product contains fluorinated greenhouse gases (R32)

# OUTDOOR UNITS



MU3R19  
MU3R21  
MU4R25

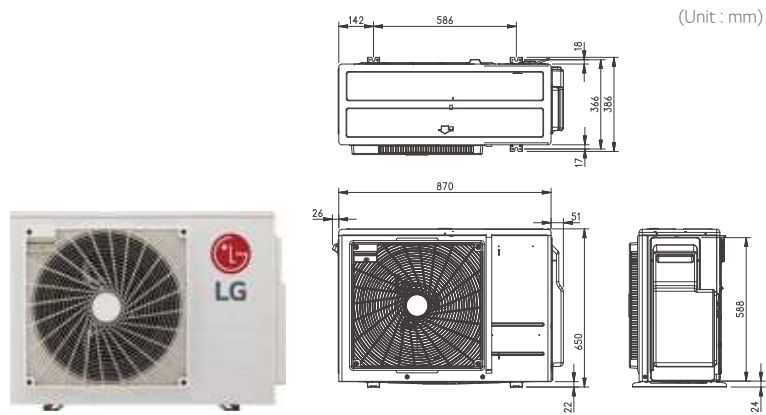

OUTDOOR UNIT				MU3R19.U21	MU3R21.U21	MU4R25.U21					
Compressor	Type	Twin Rotary			Twin Rotary	Twin Rotary					
	Capacity *	Cooling	Min / Nom / Max	kW	1.1 / 5.3 / 6.3	1.1 / 6.2 / 7.3	1.1 / 7.0 / 8.5				
Low Temperature Capacity	Heating -7°C	Max	kW			5.2	5.5	5.9			
		Power Input *	Cooling	Min / Nom / Max	kW	0.3 / 1.1 / 2.0	0.3 / 1.4 / 2.5	0.3 / 1.8 / 2.8			
Running Current	Heating	Min / Nom / Max	kW			0.3 / 1.3 / 2.0	0.3 / 1.5 / 2.4	0.3 / 1.8 / 2.9			
		Cooling	Min / Nom / Max	A	1.3 / 5.0 / 9.2	1.3 / 6.5 / 11.1	1.3 / 8.0 / 12.6				
EER	Heating	Min / Nom / Max	A			1.3 / 5.7 / 9.2	1.3 / 6.9 / 10.8	1.3 / 8.3 / 12.9			
		SEER				4.75	4.28	4.00			
COP				5.00			4.60	4.40			
SEER				8.50			8.50	8.00			
SCOP				4.40			4.40	4.40			
Pdesign (@-10°C)				kW			5.20	5.20	5.40		
Seasonal Energy Label				Cooling / Heating (A+++ to D Scale)			A+++ / A+	A+++ / A+	A++ / A+		
Annual Energy Consumption				Cooling / Heating			217 / 1,655	253 / 1,655	308 / 1,718		
Airflow Rate				Nom			m³/min	50	50	50	
Sound Pressure	Cooling	Nom	dB(A)			48	49	50			
		Heating	Nom	dB(A)			53	54	54		
Sound Power				Cooling			Max	dB(A)	63	64	66
Dimensions				W x H x D			mm	870 x 650 x 330	870 x 650 x 330	870 x 650 x 330	
Net Weight							Kg	46	46	46.2	
Refrigerant	Type			R32			R32				
	Charge			Kg			1.4	1.4	1.4		
	Additional Charge			g/m			20	20	20		
	GWP						675	675	675		
	t-CO <sub>2</sub> eq						0.945	0.945	0.945		
Operation Range (Outdoor)	Cooling	Min / Max	°C DB			-10 ~ 48	-10 ~ 48	-10 ~ 48			
		Heating	Min / Max	°C WB			-18 ~ 18	-18 ~ 18	-18 ~ 18		
Power Supply				V, Ø, Hz			1 / 220-240 / 50	1 / 220-240 / 50	1 / 220-240 / 50		
Power Supply Cable				No. x mm <sup>2</sup>			3C x 2.5	3C x 2.5	3C x 2.5		
Transmission Cable				No. x mm <sup>2</sup>			4C x 0.75	4C x 0.75	4C x 0.75		
Circuit Breaker							A	20	20		
Piping Length Total							m	50	50	70	
Piping Length per Branch				Max			m	25	25	25	
Piping Elevation Difference	IDU - ODU	Max	m			15	15	15			
		IDU - IDU	Max	m			7.5	7.5	7.5		
Piping Connection	Liquid	mm(inch) x No.		Ø 6.35 (1/4) x 3			Ø 6.35 (1/4) x 3	Ø 6.35 (1/4) x 4			
		Gas		mm(inch) x No.			Ø 9.52 (3/8) x 3	Ø 9.52 (3/8) x 3	Ø 9.52 (3/8) x 4		

※ This Product is available from Apr.2020

Notes:

- Capacities are based on the following conditions:  
Cooling : - Indoor Temperature 27°C (80.6°F) DB / 19°C (66.2°F) WB - Outdoor Temperature 35°C (95°F) DB / 24°C (75.2°F) WB  
Heating : - Indoor Temperature 20°C (68°F) DB / 15°C (59°F) WB - Outdoor Temperature 7°C (44.6°F) DB / 6°C (42.8°F) WB  
Piping Length - Interconnecting Piping Length 7.5m - Level Difference of Zero.
- \* : See page "Combination Table".
- Due to our policy of innovation some specifications may be changed without notification.
- At least two indoor units should be connected
- Minimum combination ratio should be more than 40%.
- This product contains fluorinated greenhouse gases (R32)

# OUTDOOR UNITS



MU4R27  
MU5R30



LG participates in the ECP programme for EUROVENT AC program.  
Check ongoing validity of certification  
: [www.eurovent-certification.com](http://www.eurovent-certification.com)

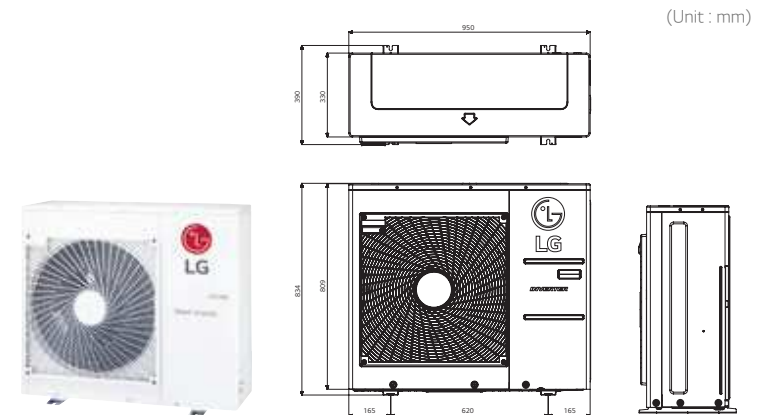

OUTDOOR UNIT				MU4R27.U40	MU5R30.U40					
Compressor	Type	Twin Rotary			Twin Rotary					
	Capacity *	Cooling	Min / Nom / Max	kW	1.3 / 7.9 / 9.5	1.3 / 8.8 / 10.6				
Low Temperature Capacity	Heating -7°C	Max	kW			6.4	7.1			
		Power Input *	Cooling	Min / Nom / Max	kW	0.4 / 1.8 / 2.9	0.4 / 2.0 / 3.4			
Running Current	Heating	Min / Nom / Max	kW			0.6 / 2.1 / 3.4	0.6 / 2.2 / 3.6			
		Cooling	Min / Nom / Max	A	1.9 / 8.1 / 13.1	1.9 / 9.1 / 15.2				
EER	Heating	Min / Nom / Max	A			2.8 / 9.4 / 15.3	2.8 / 9.7 / 16.3			
		SEER				4.39	4.40			
COP				4.39			4.70			
SEER				8.00			8.20			
SCOP				4.20			4.20			
Pdesign (@-10°C)				kW			7.00	7.40		
Seasonal Energy Label				Cooling / Heating (A+++ to D Scale)			A++ / A+	A++ / A+		
Annual Energy Consumption				Cooling / Heating			346 / 2,333	376 / 2,467		
Airflow Rate				Nom			m³/min	60	60	
Sound Pressure	Cooling	Nom	dB(A)			50	50			
		Heating	Nom	dB(A)			54	54		
Sound Power				Cooling			Max	dB(A)	65	66
Dimensions				W x H x D			mm	950 x 834 x 330	950 x 834 x 330	
Net Weight							Kg	61	61	
Refrigerant	Type			R32			R32			
	Charge			Kg			2.3	2.6		
	Additional Charge			g/m			20	20		
	GWP						675	675		
	t-CO <sub>2</sub> eq						1.55	1.76		
Operation Range (Outdoor)	Cooling	Min / Max	°C DB			-10 / 48	-10 / 48			
		Heating	Min / Max	°C WB			-18 / 18	-18 / 18		
Power Supply				V, Ø, Hz			220-240, 1, 50	220-240, 1, 50		
Power Supply Cable				No. x mm <sup>2</sup>			3C x 2.5	3C x 2.5		
Transmission Cable				No. x mm <sup>2</sup>			4C x 0.75	4C x 0.75		
Circuit Breaker							A	25		
Piping Length Total							m	70	75	
Piping Length per Branch				Max			m	25	25	
Piping Elevation Difference	IDU - ODU	Max	m			15	15			
		IDU - IDU	Max	m			7.5	7.5		
Piping Connection	Liquid	mm(inch) x No.		Ø 6.35 (1/4) x 4			Ø 6.35 (1/4) x 5			
		Gas		mm(inch) x No.			Ø 9.52 (3/8) x 4	Ø 9.52 (3/8) x 5		

Notes:

- Capacities are based on the following conditions:  
Cooling : - Indoor Temperature 27°C (80.6°F) DB / 19°C (66.2°F) WB - Outdoor Temperature 35°C (95°F) DB / 24°C (75.2°F) WB  
Heating : - Indoor Temperature 20°C (68°F) DB / 15°C (59°F) WB - Outdoor Temperature 7°C (44.6°F) DB / 6°C (42.8°F) WB  
Piping Length - Interconnecting Piping Length 7.5m - Level Difference of Zero.
- \* : See page "Combination Table".
- Due to our policy of innovation some specifications may be changed without notification.
- At least two indoor units should be connected
- Minimum combination ratio should be more than 40%.
- This product contains fluorinated greenhouse gases (R32)

## WALL MOUNTED UNITS



KBTU/H	5	7	9	12	15	18	24
KW	1.5	2.1	2.6	3.5	4.2	5.3	7.0

Wall Mounted Unit	Capacity	5	7	9	12	15	18	24
Gallery	MA09R.NF1							
	MA12R.NF1							
Mirror	AM07BP.NSJ							
	AC09BQ.NSJ							
	AC12BQ.NSJ							
	AC18BQ.NSK							
	AC24BQ.NSK							

## ARTCOOL Gallery

				MA09R.NF1	MA12R.NF1
Capacity	Cooling / Heating	Nom	kW	2.6 / 2.9	3.5 / 3.9
Power Input			W x No.	40 x 1	40 x 1
Running Current			A	0.1	0.1
Power Supply			V, Ø, Hz	220-240, 1, 50	220-240, 1, 50
Air Flow Rate		H / M / L	m³/min	7.7 / 5.9 / 4.4	8.9 / 7.3 / 5.6
Sound Pressure	Cooling	H / M / L	dB(A)	38 / 32 / 27	44 / 38 / 32
Sound Power	Cooling		dB(A)	52	54
Dehumidification Rate			l/h	1.2	1.4
Dimensions	Body	W x H x D	mm	600 x 600 x 145	600 x 600 x 145
Net Weight	Body		kg	15.0	15.0
Piping	Liquid		mm(inch)	Ø 6.35 (1/4)	Ø 6.35 (1/4)
Connections	Gas		mm(inch)	Ø 9.52 (3/8)	Ø 9.52 (3/8)

## ARTCOOL Mirror

				AM07BP.NSJ	AC09BQ.NSJ	AC12BQ.NSJ	AC18BQ.NSK	AC24BQ.NSK
Capacity	Cooling / Heating	Nom	kW	2.1 / 2.3	2.5 / 3.2	3.5 / 3.8	5.0 / 5.8	6.6 / 7.5
Power Input			W	17	18	19	39	45
Running Current			A	0.14	0.16	0.17	0.28	0.33
Power Supply			V, Ø, Hz	220-240, 1, 50	220-240, 1, 50	220-240, 1, 50	220-240, 1, 50	220-240, 1, 50
Air Flow Rate		H / M / L	m³/min	8.6 / 7.2 / 5.6	9.2 / 7.4 / 5.6	9.6 / 8.1 / 5.6	14.2 / 11.3 / 9.9	15.2 / 12.7 / 10.2
Sound Pressure	Cooling	H / M / L	dB(A)	35 / 32 / 27	36 / 33 / 27	40 / 35 / 27	44 / 38 / 35	46 / 41 / 36
Sound Power	Cooling		dB(A)	57	57	57	59	65
Dehumidification Rate			l/h	0.9	1.1	1.2	1.9	2.6
Dimension	Body	W x H x D	mm	837 x 308 x 192	837 x 308 x 192	837 x 308 x 192	998 x 345 x 212	998 x 345 x 212
Net weight	Body		kg	9.1	9.9	9.9	13.2	11.6
Piping	Liquid		mm(inch)	Ø 6.35 (1/4)	Ø 6.35 (1/4)	Ø 6.35 (1/4)	Ø 6.35 (1/4)	Ø 6.35 (1/4)
Connection	Gas		mm(inch)	Ø 9.52 (3/8)	Ø 9.52 (3/8)	Ø 9.52 (3/8)	Ø 12.7 (1/2)	Ø 12.7 (1/2)

\* This product contains Fluorinated greenhouse gases (R32).

※ For our policy of continuous product improvement, specification, design and features are subject to change without prior notice.

## WALL MOUNTED UNITS



KBTU/H	5	7	9	12	15	18	24
KW	1.5	2.1	2.6	3.5	4.2	5.3	7.0

Wall Mounted Unit	Capacity	5	7	9	12	15	18	24
Silver	AC09SQ.NSJ							
	AC12SQ.NSJ							
Air - Purifying	AP09RT.NSJ							
	AP12RT.NSJ							
	AC18SQ.NSK							

## ARTCOOL Silver

				AC09SQ.NSJ	AC12SQ.NSJ	AC18SQ.NSK
Capacity	Cooling / Heating	Nom	kW	2.5 / 3.2	3.5 / 3.8	5.0 / 5.8
Power Input			W	18	19	39
Running Current			A	0.16	0.17	0.28
Power Supply			V, Ø, Hz	220-240, 1, 50	220-240, 1, 50	220-240, 1, 50
Air Flow Rate		H / M / L	m³/min	9.2 / 7.4 / 5.6	9.6 / 8.1 / 5.6	14.2 / 11.3 / 9.9
Sound Pressure	Cooling	H / M / L	dB(A)	36 / 33 / 27	40 / 35 / 27	44 / 38 / 35
Sound Power	Cooling		dB(A)	57	57	59
Dehumidification Rate			l/h	1.1	1.2	1.9
Dimension	Body	W x H x D	mm	837 x 308 x 192	837 x 308 x 192	998 x 345 x 212
Net weight	Body		kg	9.9	9.9	13.2
Piping	Liquid		mm(inch)	Ø 6.35 (1/4)	Ø 6.35 (1/4)	Ø 6.35 (1/4)
Connection	Gas		mm(inch)	Ø 9.52 (3/8)	Ø 9.52 (3/8)	Ø 12.7 (1/2)

## Air - Purifying

				AP09RT.NSJ	AP12RT.NSJ
Capacity	Cooling / Heating	Nom	kW	2.5 / 3.3	3.5 / 4.0
Power Input			W x No.	21	22
Running Current			A	0.18	0.19
Power Supply			V, Ø, Hz	220-240, 1, 50	220-240, 1, 50
Air Flow Rate		H / M / L	m³/min	10 / 6.6 / 4.2	10 / 6.6 / 4.2
Sound Pressure	Cooling	H / M / L	dB(A)	42 / 35 / 27	42 / 35 / 27
Sound Power	Cooling		dB(A)	59	59
Dehumidification Rate			l/h	0.9	0.9
Dimensions	Body	W x H x D	mm	857 x 348 x 189	857 x 348 x 189
Net Weight	Body		kg	9.5	9.5
Piping	Liquid		mm(inch)	Ø 6.35 (1/4)	Ø 6.35 (1/4)
Connections	Gas		mm(inch)	Ø 9.52 (3/8)	Ø 9.52 (3/8)

\* This product contains Fluorinated greenhouse gases (R32).

※ For our policy of continuous product improvement, specification, design and features are subject to change without prior notice.



# WALL MOUNTED UNITS



KBTU/H	5	7	9	12	15	18	24
KW	1.5	2.1	2.6	3.5	4.2	5.3	7.0

Wall Mounted Unit	Deluxe		●	●●	●●	●●	●●	●●
			DM07RP.NSJ	DC09RQ.NSJ	DC12RQ.NSJ		DC18RQ.NSK	DC24RQ.NSK

## DELUXE

				DM07RP.NSJ	DC09RQ.NSJ	DC12RQ.NSJ	DC18RQ.NSK	DC24RQ.NSK
Capacity	Cooling / Heating	Nom	kW	2.1 / 2.3	2.5 / 3.2	3.5 / 4.0	5.0 / 5.8	6.6 / 7.5
Power Input		Nom	W	17	18	19	39	45
Running Current		Nom	A	0.15	0.16	0.17	0.28	0.33
Power Supply		V, ∅, Hz		220-240, 1, 50	220-240, 1, 50	220-240, 1, 50	220-240, 1, 50	220-240, 1, 50
Air Flow Rate		H / M / L	m³/min	7.5 / 6.1 / 4.9	7.7 / 6.4 / 5.0	8.1 / 6.7 / 5.3	14.2 / 11.3 / 9.9	15.2 / 12.7 / 10.2
Sound Pressure	Cooling	H / M / L	dB(A)	35 / 31 / 26	36 / 32 / 27	38 / 34 / 29	44 / 38 / 34	47 / 41 / 36
Sound Power	Cooling		dB(A)	56	56	56	60	64
Dehumidification Rate			l/h	0.9	1.1	1.2	1.9	2.6
Dimension		W x H x D	mm	837 x 308 x 189	837 x 308 x 189	837 x 308 x 189	998 x 345 x 210	998 x 345 x 210
Net weight			kg	8.3	8.3	8.3	12.0	12.0
Piping Connection	Liquid		mm(inch)	∅ 6.35 (1/4)	∅ 6.35 (1/4)	∅ 6.35 (1/4)	∅ 6.35 (1/4)	∅ 6.35 (1/4)
	Gas		mm(inch)	∅ 9.52 (3/8)	∅ 9.52 (3/8)	∅ 9.52 (3/8)	∅ 12.7 (1/2)	∅ 12.7 (1/2)

# WALL MOUNTED UNITS



KBTU/H	5	7	9	12	15	18	24
KW	1.5	2.1	2.6	3.5	4.2	5.3	7.0

Wall Mounted Unit	Standard Plus		●	●	●●	●●	●●	●●	
			PM05SP.NSJ	PM07SP.NSJ	PC09SQ.NSJ	PC12SQ.NSJ	PM15SP.NSJ	PC18SQ.NSK	PC24SQ.NSK
			●	●	●	●	●	●	
			MJ05PC.NSJ	MJ07PC.NSJ	MJ09PC.NSJ	MJ12PC.NSJ	MJ15PC.NSJ	MJ18PC.NSK	MJ24PC.NSK

## STANDARD PLUS

				PM05SP.NSJ	PM07SP.NSJ	PC09SQ.NSJ	PC12SQ.NSJ	PM15SP.NSJ	PC18SQ.NSK	PC24SQ.NSK
Capacity	Cooling / Heating	Nom	kW	1.5 / 1.6	2.1 / 2.3	2.5 / 3.2	3.5 / 3.8	4.2 / 5.4	5.0 / 5.8	6.6 / 7.5
Power Input		Nom	W	16	17	18	19	21	39	45
Running Current		Nom	A	0.13	0.14	0.16	0.17	0.18	0.28	0.33
Power Supply		V, ∅, Hz		220-240, 1, 50	220-240, 1, 50	220-240, 1, 50	220-240, 1, 50	220-240, 1, 50	220-240, 1, 50	220-240, 1, 50
Air Flow Rate		H / M / L	m³/min	8.3 / 6.7 / 5.6	8.6 / 7.2 / 5.6	9.2 / 7.4 / 5.6	9.6 / 8.1 / 5.6	100 / 85 / 61	142 / 113 / 99	152 / 127 / 102
Sound Pressure		H / M / L	dB(A)	34 / 31 / 27	35 / 32 / 27	36 / 33 / 27	40 / 35 / 27	41 / 36 / 29	44 / 38 / 35	46 / 41 / 36
Sound Power			dB(A)	57	57	57	57	57	59	65
Dehumidification Rate			l/h	0.9	0.9	1.1	1.2	1.2	1.9	2.6
Dimension		W x H x D	mm	837 x 308 x 189	837 x 308 x 189	837 x 308 x 189	837 x 308 x 189	837 x 308 x 189	998 x 345 x 210	998 x 345 x 210
Net weight			kg	7.4	7.4	8.7	8.7	8.7	12.0	12.8
Piping Connection	Liquid		mm(inch)	∅ 6.35 (1/4)	∅ 6.35 (1/4)	∅ 6.35 (1/4)	∅ 6.35 (1/4)	∅ 6.35 (1/4)	∅ 6.35 (1/4)	∅ 6.35 (1/4)
	Gas		mm(inch)	∅ 9.52 (3/8)	∅ 9.52 (3/8)	∅ 9.52 (3/8)	∅ 9.52 (3/8)	∅ 9.52 (3/8)	∅ 12.7 (1/2)	∅ 12.7 (1/2)

				MJ05PC.NSJ	MJ07PC.NSJ	MJ09PC.NSJ	MJ12PC.NSJ	MJ15PC.NSJ	MJ18PC.NSK	MJ24PC.NSK
Capacity	Cooling / Heating	Nom	kW	1.5 / 1.6	2.1 / 2.3	2.5 / 3.2	3.5 / 3.8	4.2 / 5.4	5.0 / 5.8	6.6 / 7.5
Power Input		Nom	W	16	17	18	19	21	39	45
Running Current		Nom	A	0.13	0.14	0.16	0.17	0.18	0.28	0.33
Power Supply		V, ∅, Hz		220-240, 1, 50	220-240, 1, 50	220-240, 1, 50	220-240, 1, 50	220-240, 1, 50	220-240, 1, 50	220-240, 1, 50
Air Flow Rate		H / M / L	m³/min	8.3 / 6.7 / 5.6	8.6 / 7.2 / 5.6	9.2 / 7.4 / 5.6	9.6 / 8.1 / 5.6	100 / 85 / 61	142 / 113 / 99	152 / 127 / 102
Sound Pressure		H / M / L	dB(A)	34 / 31 / 27	35 / 32 / 27	36 / 33 / 27	40 / 35 / 27	41 / 36 / 29	44 / 38 / 35	46 / 41 / 36
Sound Power			dB(A)	57	57	57	57	57	59	65
Dehumidification Rate			l/h	0.9	0.9	1.1	1.2	1.2	1.9	2.6
Dimension		W x H x D	mm	837 x 308 x 189	837 x 308 x 189	837 x 308 x 189	837 x 308 x 189	837 x 308 x 189	998 x 345 x 210	998 x 345 x 210
Net weight			kg	8.7	8.7	8.7	8.7	8.7	12.0	12.8
Piping Connection	Liquid		mm(inch)	∅ 6.35 (1/4)	∅ 6.35 (1/4)	∅ 6.35 (1/4)	∅ 6.35 (1/4)	∅ 6.35 (1/4)	∅ 6.35 (1/4)	∅ 6.35 (1/4)
	Gas		mm(inch)	∅ 9.52 (3/8)	∅ 9.52 (3/8)	∅ 9.52 (3/8)	∅ 9.52 (3/8)	∅ 9.52 (3/8)	∅ 12.7 (1/2)	∅ 12.7 (1/2)

\* This product contains Fluorinated greenhouse gases (R32).  
 ※ For our policy of continuous product improvement, specification, design and features are subject to change without prior notice.

## WALL MOUNTED UNITS



KBTU/H		5	7	9	12	15	18	24
KW		1.5	2.1	2.6	3.5	4.2	5.3	7.0
Wall Mounted Unit	Standard2	NEW		MS07ETNSJ	S09ETNSJ	S12ETNSJ	S18ETNSK	S24ETNSK

## Standard2

				MS07ET.NSJ	S09ET.NSJ	S12ET.NSJ	S18ET.NSJ	S24ET.NSJ
Capacity	Cooling / Heating	Nom	kW	2.1 / 2.3	2.5 / 3.2	3.5 / 3.8	5.0 / 5.8	6.6 / 7.5
Power Input		Nom	W	17	18	19	39	45
Running Current		Nom	A	0.14	0.16	0.17	0.28	0.33
Power Supply			V, $\emptyset$ , Hz	220-240, 1, 50	220-240, 1, 50	220-240, 1, 50	220-240, 1, 50	220-240, 1, 50
Air Flow Rate		H / M / L	m <sup>3</sup> /min	8.6 / 7.2 / 5.6	9.2 / 7.4 / 5.6	9.6 / 8.1 / 5.6	14.2 / 11.3 / 9.9	15.2 / 12.7 / 10.2
Sound Pressure	Cooling	H / M / L	dB(A)	35 / 32 / 27	36 / 33 / 27	40 / 35 / 27	44 / 38 / 35	46 / 41 / 36
Sound Power	Cooling		dB(A)	57	57	57	59	65
Dehumidification Rate			l/h	0.9	0.9	0.9	0.9	0.9
Dimension		W x H x D	mm	837 x 308 x 189	837 x 308 x 189	837 x 308 x 189	998 x 345 x 210	998 x 345 x 210
Net weight			kg	8.7	8.7	8.7	11.9	12.7
Piping Connection	Liquid		mm(inch)	$\emptyset$ 6.35 (1/4)	$\emptyset$ 6.35 (1/4)	$\emptyset$ 6.35 (1/4)	$\emptyset$ 6.35 (1/4)	$\emptyset$ 6.35 (1/4)
	Gas		mm(inch)	$\emptyset$ 9.52 (3/8)	$\emptyset$ 9.52 (3/8)	$\emptyset$ 9.52 (3/8)	$\emptyset$ 12.7 (1/2)	$\emptyset$ 12.7 (1/2)

## CEILING MOUNTED CASSETTE



KBTU/H		5	7	9	12	15	18	24
KW		1.5	2.1	2.6	3.5	4.2	5.3	7.0
Ceiling Mounted Cassette	1 Way Cassette			MT09R.NU1	MT11R.NU1			
	4 Way Cassette	MT06R.NRO	MT08R.NRO	CT09F.NRO	CT12F.NRO		CT18F.NQ0	CT24F.NB0

\* Dual vane is applied to 24k (4Way cassette)

## 1Way Cassette

INDOOR				MT09R.NU1	MT11R.NU1
Capacity	Cooling / Heating	Nom	kW	2.6 / 2.9	3.5 / 3.9
Power Input		Nom	W	20	20
Running Current		Nom	A	0.2	0.2
Power Supply			V, $\emptyset$ , Hz	220-240, 1, 50	220-240, 1, 50
Air Flow Rate		H / M / L	m <sup>3</sup> /min	7.5 / 7.3 / 6.8	8.1 / 7.4 / 7.0
Sound Pressure	Cooling	H / M / L	dB(A)	36 / 34 / 32	37 / 36 / 33
Sound Power	Cooling	Max	dB(A)	54	57
Dehumidification Rate			l/h	1.1	1.2
Dimensions	Body	W x H x D	mm	860 x 132 x 450	860 x 132 x 450
Net Weight	Body		kg	13.5	13.5
Piping Connection	Liquid		mm(inch)	$\emptyset$ 6.35 (1/4)	$\emptyset$ 6.35 (1/4)
	Gas		mm(inch)	$\emptyset$ 9.52 (3/8)	$\emptyset$ 9.52 (3/8)
	Model			PT-UUC1	PT-UUC1
Decoration Panel	Color			Morning Fog (RAL120-4)	Morning Fog (RAL120-4)
	Dimensions	W x H x D	mm	1,100 x 34 x 500	1,100 x 34 x 500
	Weight		kg	4.4	4.4

## 4Way Cassette



				MT06R.NRO	MT08R.NRO	CT09F.NRO	CT12F.NRO	CT18F.NQ0	CT24F.NB0
Capacity	Cooling / Heating	Nom	kW	1.5 / 1.6	2.1 / 2.3	2.6 / 2.9	3.5 / 3.9	5.3 / 5.8	6.7 / 7.5
Power Input		Nom	W	20	20	20	20	40	60
Running Current		Nom	A	0.40	0.40	0.40	0.40	0.40	0.60
Power Supply			V, $\emptyset$ , Hz	220-240, 1, 50	220-240, 1, 50	220-240, 1, 50	220-240, 1, 50	220-240, 1, 50	220-240, 1, 50
Air Flow Rate		H / M / L	m <sup>3</sup> /min	7.5 / 6.0 / 5.0	7.5 / 6.0 / 5.0	8.5 / 7.0 / 6.0	9.5 / 8.0 / 7.0	13.0 / 12.0 / 11.0	17.0 / 15.0 / 13.0
Sound Pressure		H / M / L	dB(A)	31 / 27 / 24	31 / 27 / 24	36 / 33 / 30	38 / 35 / 32	41 / 39 / 36	38 / 36 / 34
Sound Power			dB(A)	48	48	52	52	57	57
Dehumidification Rate			l/h	-	-	0.9	1.4	2.0	2.7
Dimension		W x H x D	mm	570 x 214 x 570	570 x 214 x 570	570 x 214 x 570	570 x 214 x 570	570 x 256 x 570	840 x 204 x 840
Net weight			kg	14.0	14.0	14.0	14.0	14.3	20.5
Piping Connection	Liquid		mm(inch)	$\emptyset$ 6.35 (1/4)	$\emptyset$ 6.35 (1/4)	$\emptyset$ 6.35 (1/4)	$\emptyset$ 6.35 (1/4)	$\emptyset$ 6.35 (1/4)	$\emptyset$ 6.35 (1/4)
	Gas		mm(inch)	$\emptyset$ 9.52 (3/8)	$\emptyset$ 9.52 (3/8)	$\emptyset$ 9.52 (3/8)	$\emptyset$ 9.52 (3/8)	$\emptyset$ 12.7 (1/2)	$\emptyset$ 12.7 (1/2)
	Model			PT-QCHW0	PT-QCHW0	PT-QCHW0	PT-QCHW0	PT-QCHW0	PT-MCHW0
Decoration Panel	Color			Morning Fog (RAL 120-4)					
	Dimensions	W x H x D	mm	620 x 20 x 620	620 x 20 x 620	620 x 20 x 620	620 x 20 x 620	620 x 20 x 620	950 x 35 x 950
	Weight		kg	3.0	3.0	3.0	3.0	3.0	6.3

\* This product contains Fluorinated greenhouse gases (R32).

※ For our policy of continuous product improvement, specification, design and features are subject to change without prior notice.

# CEILING CONCEALED DUCT



		05	07	09	12	15	18	24
		1.5	2.1	2.6	3.5	4.2	5.3	7.0
Ceiling Concealed Duct	Mid / High Static Pressure  <sup>NEW</sup>	-	-	-	-	-	●○ CM18FN10	●○ CM24FN10
	Low Static Pressure  <sup>NEW</sup>	-	-	●○ CL09FN50	●○ CL12FN50	-	●○ CL18FN60	●○ CL24FN30

## Duct (Mid Static)

				CM18F.N10	CM24F.N10
Capacity	Cooling / Heating	Nom	kW	5.3 / 5.8	7.0 / 7.7
Power Input		Nom	W	160	180
Running Current		Nom	A	0.90	1.00
Power Supply			V, Ø, Hz	220-240, 1, 50	220-240, 1, 50
Air Flow Rate		H / M / L	m <sup>3</sup> /min	16.5 / 14.5 / 13.0	18.0 / 16.5 / 14.5
Sound Pressure		H / M / L	dB(A)	34 / 32 / 30	35 / 34 / 32
Sound Power			dB(A)	59	60
Dehumidification Rate			l/h	1.5	2.5
Dimension		W x H x D	mm	900 x 270 x 700	900 x 270 x 700
Net weight			kg	26.5	26.5
Piping Connection	Liquid		mm(inch)	Ø6.35 (1/4)	Ø6.35 (1/4)
	Gas		mm(inch)	Ø12.7 (1/2)	Ø12.7 (1/2)
External Static Pressure	Min-Max		mmAq (Pa)	2-15 (20-147)	2-15 (20-147)

## Duct (Low Static)

				CL09F.N50	CL12F.N50	CL18F.N60	CL24F.N30
Capacity	Cooling / Heating	Nom	kW	2.6 / 2.9	3.5 / 3.9	5.3 / 5.8	7.0 / 7.7
Power Input		Nom	W	100	100	140	160
Running Current		Nom	A	0.80	0.80	0.80	1.00
Power Supply			V, Ø, Hz	220-240, 1, 50	220-240, 1, 50	220-240, 1, 50	220-240, 1, 50
Air Flow Rate		H / M / L	m <sup>3</sup> /min	10.0 / 8.5 / 7.0	10.0 / 8.5 / 7.0	15.0 / 12.5 / 10.0	20.0 / 16.0 / 12.0
Sound Pressure		H / M / L	dB(A)	31 / 28 / 27	31 / 28 / 27	36 / 34 / 31	39 / 35 / 32
Sound Power			dB(A)	55	55	54	58
Dehumidification Rate			l/h	0.55	1.11	1.58	2.65
Dimension		W x H x D	mm	900 x 190 x 700	900 x 190 x 700	900 x 190 x 700	1,100 x 190 x 700
Net weight			kg	24.0	24.0	24.0	27.0
Piping Connection	Liquid		mm(inch)	Ø6.35 (1/4)	Ø6.35 (1/4)	Ø6.35 (1/4)	Ø6.35 (1/4)
	Gas		mm(inch)	Ø9.52 (3/8)	Ø9.52 (3/8)	Ø12.7 (1/2)	Ø12.7 (1/2)
External Static Pressure	Min-Max		mmAq (Pa)	0-5 (0-50)	0-5 (0-50)	0-5 (0-50)	0-5 (0-50)























# R410A MULTI SPLIT



R410A MULTI SPLIT

## OUTDOOR UNITS



RESIDENTIAL  
MULTI SPLIT

MU5M40

(Unit : mm)

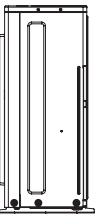
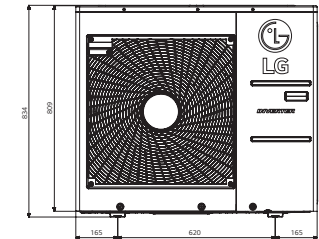
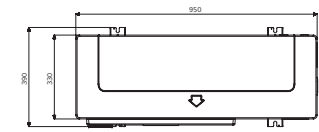

OUTDOOR				MU5M40.U44
Compressor	Type			Scroll
Capacity*	Cooling	Min / Nom / Max	kW	1.3 / 11.2 / 14.7
	Heating	Min / Nom / Max	kW	1.5 / 12.5 / 16.0
Low Temperature Capacity	Heating -7°C	Max	kW	11.0
Power Input*	Cooling	Min / Nom / Max	kW	0.4 / 3.3 / 5.5
	Heating	Min / Nom / Max	kW	0.4 / 3.8 / 5.6
Running Current*	Cooling	Min / Nom / Max	A	1.8 / 14.9 / 24.9
	Heating	Min / Nom / Max	A	1.9 / 17.0 / 25.4
EER				3.40
COP				3.33
SEER				7.10
SCOP				4.00
Pdesign (@-10°C)				8.90
Season Energy Label	Cooling / Heating (A+++ to D Scale)			A++ / A+
Annual Energy Consumption	Cooling / Heating			552 / 3,114
Airflow Rate	Nom		m <sup>3</sup> /min	80
Sound Pressure Level	Cooling	Nom	dB(A)	53
	Heating	Nom	dB(A)	55
Sound Power Level	Cooling	Max	dB(A)	67
Dimensions	W x H x D		mm	950 x 834 x 330
Net Weight				73
Refrigerant	Type			R410A
	Charge			kg
	Additional Charge			g/m
	GWP			2087.5
Operation Range (Outdoor)	Cooling	Min / Max	°C DB	-10 - 48
	Heating	Min / Max	°C WB	-25 - 18
Power Supply				V, Ø, Hz
Power Supply Cable				No. x mm <sup>2</sup>
Transmission Cable				No. x mm <sup>2</sup>
Circuit Breaker				A
Piping Length Total				m
Piping Length per Branch	Max		m	25
Piping Elevation Difference	IDU - ODU	Max	m	15
	IDU - IDU	Max	m	7.5
Piping Connection	Liquid	mm(inch) x No.		Ø 6.35 (1/4) x 5
	Gas	mm(inch) x No.		Ø 9.52 (3/8) x 5

※ For our policy of continuous product improvement, specification, design and features are subject to change without prior notice.

※ This Product is available from Apr.2020

Note : 1. Capacities are based on the following conditions:

Cooling : - Indoor Temperature 27°C (80.6°F) DB / 19°C (66.2°F) WB - Outdoor Temperature 35°C (95°F) DB / 24°C (75.2°F) WB

Heating : - Indoor Temperature 20°C (68°F) DB / 15°C (59°F) WB - Outdoor Temperature 7°C (44.6°F) DB / 6°C (42.8°F) WB

Piping Length - Interconnecting Piping Length 7.5m - Level Difference of Zero.

2. \* : See page "Combination Table".

3. Due to our policy of innovation some specifications may be changed without notification.

4. At least two indoor units should be connected.

5. Minimum combination capacity rate should be more than 40%.

6. This product contains fluorinated greenhouse gases (R410A)



# CEILING & FLOOR CONVERTIBLE

## Flexible Installation

The ceiling and floor models can be installed either on the ceiling or on the floor. This saves space when installed in the shops or offices.

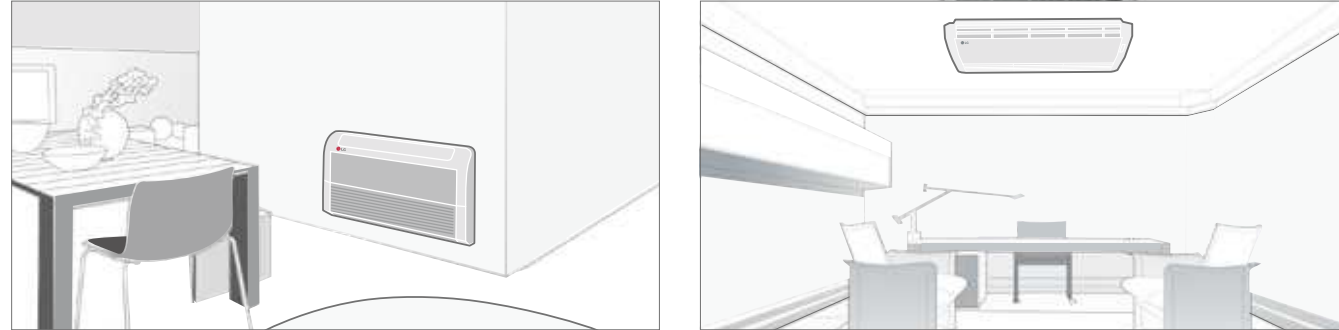

\* Ceiling & Floor: CV09 NE2 / CV12 NE2

## Air Flow Direction Control

Vertical air flow direction can be adjusted using remote controller, and horizontal airflow direction can be adjusted manually.

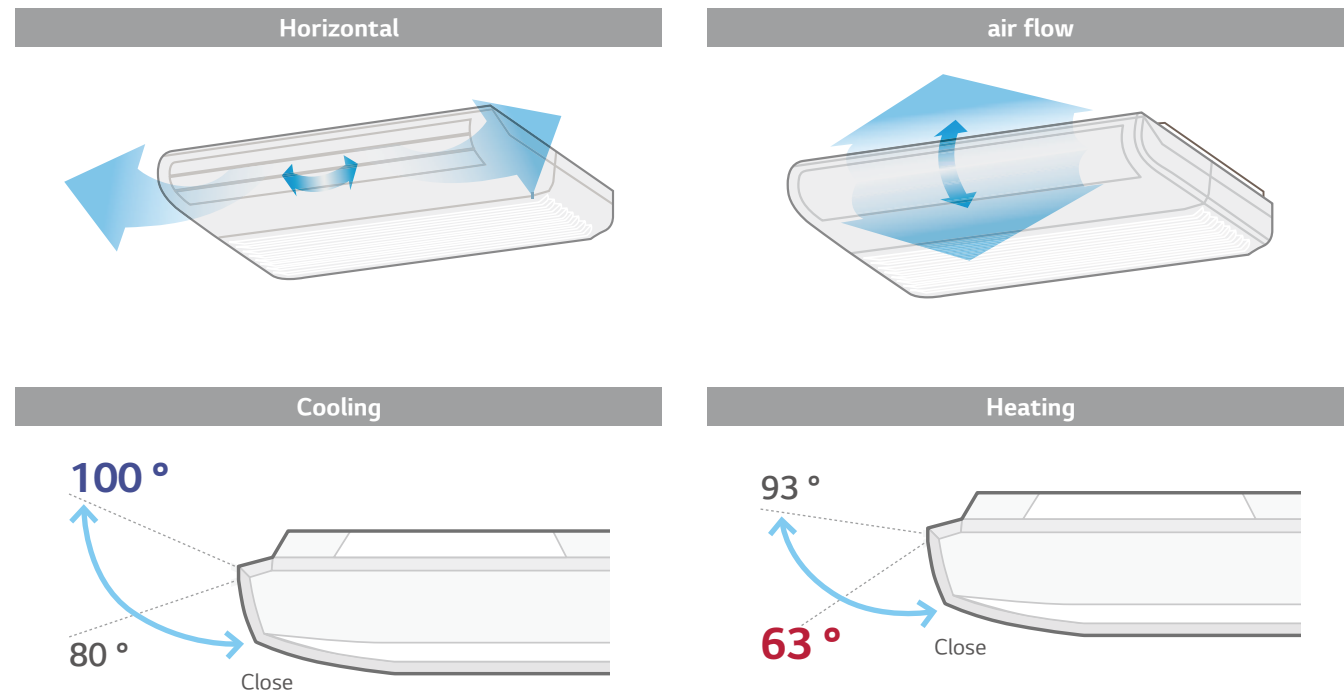

# CEILING & FLOOR CONVERTIBLE

CAPACITY (KW )		2.6	3.5	5.3	7.0
Ceiling & Floor Convertible unit		CV09.NE2	CV12.NE2	-	-

## Ceiling & Floor Convertible unit

INDOOR				CV09.NE2	CV12.NE2
Capacity	Cooling / Heating	Nom	kW	2.6 / 2.9	3.5 / 3.9
Power Input		Nom	W	30	40
Running Current		Nom	A	0.4	0.4
Power Supply			V, Ø, Hz	220-240, 1, 50	220-240, 1, 50
Air Flow Rate		H / M / L	m <sup>3</sup> /min	7.6 / 6.9 / 6.2	9.2 / 7.6 / 6.6
Sound Pressure	Cooling	H / M / L	dB(A)	38 / 35 / 31	40 / 36 / 32
Sound Power	Cooling	Max	dB(A)	52	56
Dehumidification Rate			l/h	1.2	1.2
Dimensions	Body	W x H x D	mm	900 x 490 x 200	900 x 490 x 200
Net Weight	Body		kg	13.7	13.7
Piping	Liquid		mm(inch)	Ø6.35 (1/4)	Ø6.35 (1/4)
Connection	Gas		mm(inch)	Ø9.52 (3/8)	Ø9.52 (3/8)

※ For our policy of continuous product improvement, specification, design and features are subject to change without prior notice.  
 Note : 1. Capacities are based on the following conditions :  
 Cooling : - Indoor Temperature 27°C (80.6°F) DB / 19°C (66.2°F) WB - Outdoor Temperature 35°C (95°F) DB / 24°C (75.2°F) WB  
 Heating : - Indoor Temperature 20°C (68°F) DB / 15°C (59°F) WB - Outdoor Temperature 7°C (44.6°F) DB / 6°C (42.8°F) WB  
 Piping Length - Interconnecting Piping Length 7.5m - Level Difference of Zero  
 2. Definition of Power Input Nominal conditions – Performance tested under EN14511  
 3. Due to our policy of innovation some specifications may be changed without notification  
 4. This product contains fluorinated greenhouse gases (R410A)



# CONSOLE

## Optimised Air Flow for Cooling & Heating

During cooling operation, the vane adjusts upwards to direct air flow toward the ceiling. During heating operation, the van directs the air flow toward the floor to balance out the room temperature. A wireless controller is included with the indoor console unit.

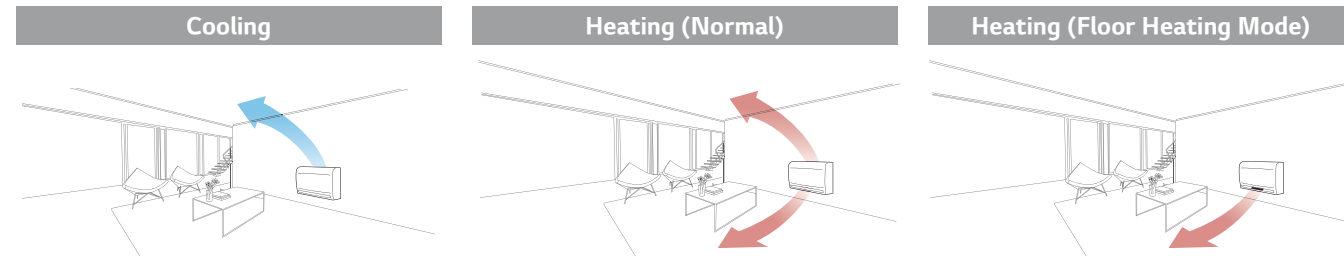

## Quick Floor Heating

Console air conditioners offer a fast and powerful performance. Using the floor heating mode, console air conditioners provide faster floor heating and help to reach the desired temperature quickly.

	Company A	Electric Heater	LG	LG Floor Heating Mode
Vertical				
Horizontal				
<b>Lead Time for Heating (13°C - 21°C)</b>	12 minutes 30 seconds	50 minutes	<b>9 minutes 30 seconds</b>	<b>8 minutes 40 seconds</b>

(Test Condition :Target Temp 23°C, Indoor Room : 13°C-, Outdoor Room : 7°C)

## 5-Step Vane Control

There are 5 different stages to control air flow direction.



# CONSOLE

	CAPACITY (KW)	2.6	3.5	5.3
Console		CQ09.NAO	CQ12.NAO	CQ18.NAO

## Console

INDOOR				CQ09.NAO
Capacity	Cooling / Heating	Nom	kW	2.6 / 2.9
Power Input		Nom	W	20
Running Current		Nom	A	0.6
Power Supply			V, Ø, Hz	220-240, 1, 50
Air Flow Rate		H / M / L	m³/min	8.5 / 6.7 / 5.0
Sound Pressure	Cooling	H / M / L	dB(A)	38 / 32 / 27
Sound Power	Cooling	Max	dB(A)	53
Dehumidification Rate			l/h	1.2
Dimensions	Body	W x H x D	mm	700 x 600 x 210
Net Weight	Body		kg	14.0
Piping	Liquid		mm(inch)	Ø6.35 (1/4)
Connection	Gas		mm(inch)	Ø9.52 (3/8)

\* CQ09, CQ12, CQ18 are compatible between SCAC and MULTI.

INDOOR				CQ12.NAO	CQ18.NAO
Capacity	Cooling / Heating	Nom	kW	3.5 / 3.9	5.3 / 5.8
Power Input		Nom	W	20	40
Running Current		Nom	A	0.6	0.7
Power Supply			V, Ø, Hz	220-240, 1, 50	220-240, 1, 50
Air Flow Rate		H / M / L	m³/min	9.0 / 6.9 / 5.2	10.1 / 8.6 / 7.2
Sound Pressure	Cooling	H / M / L	dB(A)	39 / 32 / 27	44 / 39 / 35
Sound Power	Cooling	Max	dB(A)	56	60
Dehumidification Rate			l/h	1.4	2.3
Dimensions	Body	W x H x D	mm	700 x 600 x 210	700 x 600 x 210
Net Weight	Body		kg	14.0	14.0
Piping	Liquid		mm(inch)	Ø6.35 (1/4)	Ø6.35 (1/4)
Connection	Gas		mm(inch)	Ø9.52 (3/8)	Ø12.7 (1/2)

※ For our policy of continuous product improvement, specification, design and features are subject to change without prior notice.

Note : 1. Capacities are based on the following conditions :

Cooling : - Indoor Temperature 27°C (80.6°F) DB / 19°C (66.2°F) WB - Outdoor Temperature 35°C (95°F) DB / 24°C (75.2°F) WB

Heating : - Indoor Temperature 20°C (68°F) DB / 15°C (59°F) WB - Outdoor Temperature 7°C (44.6°F) DB / 6°C (42.8°F) WB

Piping Length - Interconnecting Piping Length 7.5m - Level Difference of Zero

2. Definition of Power Input Nominal conditions - Performance tested under EN14511

3. Due to our policy of innovation some specifications may be changed without notification

4. This product contains fluorinated greenhouse gases (R410A)

# LG WI-FI MODEM

Control LG air conditioners via using the internet devices as Android or iOS bases smartphones

PWFMDD200



## Features

- Access LG air conditioner anytime and from anywhere with Wi-Fi equipped device
- LG's exclusive Home Appliances control app(SmartThinQ) is available
- Simple operation for various functions
  - On/Off
  - Fan Speed
  - Energy Monitoring <sup>1)</sup>
  - Operation Mode
  - Vane Control <sup>2)</sup>
  - Filter Management
  - Current/Set Temperature
  - Reservation (Sleep, Weekly On/Off)
  - Error check



MODEL NAME	PWFMDD200
Size (W x H x D, mm)	48 x 68 x 14
Interfaceable Products	Multi Indoor unit <sup>3)</sup>
Connection Type	Indoor unit 1:1
Communication Frequency	2.4 GHz
Wireless Standards	IEEE 802.11b/g/n
Mobile Application	LG Smart ThinQ (Android v4.1(Jellybean) or higher, iPhone iOS 9.0 or higher)
Optional Extension Cable	PWYREW000 (10m extension)

\* Functionality may be different according to each IDU model  
 \* User interface of application shall be revised for its design and contents improvement  
 \* Application is optimized for smartphone use, so it may not be well functioning with tablet devices  
 1) LG Centralized controller and PDI installation is required for this function  
 2) Vane Control may not be possible according to the type of Indoor unit  
 3) For the compatibility with Indoor unit, please contact regional office

## Overview

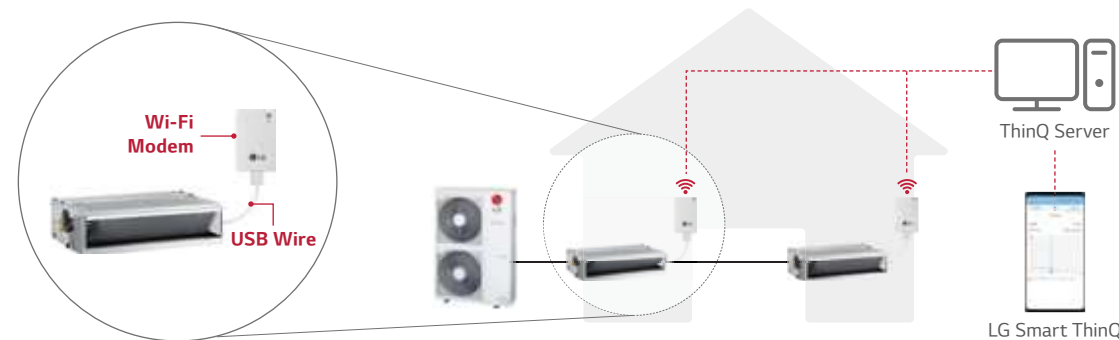

\* Search "LG Smart ThinQ" on Google market or Appstore then download the app.  
 \* Internet service with Wi-Fi connection has to be available

# ACCESSORIES

## Standard Wired Remote Controller



Model Name	PREMTB100 PREMTBB10	PREMTB001 PREMTBB01
Operation Mode	On/Off, Fan Speed Control, Temperature Setting	
Mode Change	Cooling / Heating / Auto / Dehumidification / Fan	
Auto Swing / Vane Control	•	•
Reservation	Simple / Sleep / On, Off / Weekly / Holiday	
Time Display	•	•
Electrical Failure Compensation	•	•
Child Lock	•	•
Operation Status LED	•	•
Indoor Temperature Display	•	•
Wireless Remote Controller Receiver	-	•
Size (W x H x D, mm)	120 x 120 x 16	120 x 121 x 16
Backlight	•	•

\* Refer to each model PDB for applicable models.

## Remote Controller



PQWRHQ0FDB

## PI 485



PMNFP14A1

Power : Single phase AC 220V 50/60Hz  
 Max. no of the indoor units that can be connected: 64 UNITS  
 Model applied : RAC / Multi / Single / Therma V  
 \* Refer to each product PDB for applicable models

## Dry Contact



MODEL	PDRYCB000	PDRYCB400	PDRYCB300	PDRYCB500
Contact Point	1 Control Point	2 Control Point	8 Control Point	Modbus RTU
Power Input	AC 220V from outside power source	DC 5V & 12V from indoor unit PCB	DC 5V & 12V from indoor unit PCB	DC 5V & 12 V from indoor unit PDB
Voltage / Non Voltage Input		•	•	
On / Off Control	•	•	•	•
Lock / Unlock	•	•	•	
Fan Speed Setting			•	•
Thermo Off		•	•	
Energy Saving		•		
Temperature Setting		•	•	•
Error Monitoring	•	•	•	•
Operation Monitoring	•	•	•	•

\* Refer to each product PDB for applicable models

# ACCESSORIES

## Distributor Box

### PMBD3620, PMBD3630, PMBD3640

Easy installation using the range of Distributor Boxes.

For	2 Indoors	3 Indoors	4 Indoors
Distributor	 PMBD3620	 PMBD3630	 PMBD3640

Various distributors can make much easier installation for any sites

### Features

- Distribution of refrigerant to various indoor units.
- 3 models (2, 3, 4 Indoor Units)
- EEV included
- Controlling PCB inside the unit
- Internally insulated (Prevents any chances of drainage)
- Flare joints for easy and clean installation
- Compact design (Low height)
- Flexible installation



### Specification

		PMBD3620	PMBD3630	PMBD3640
Connectable Indoor Units	Number of Indoor Units	1 - 2	1 - 3	1 - 4
	Capacity	5k / 7k / 9k / 12k / 18k / 24k	5k / 7k / 9k / 12k / 18k / 24k	5k / 7k / 9k / 12k / 18k / 24k
Power Source	V, Ø, Hz	220-240, 1, 50	220-240, 1, 50	220-240, 1, 50
Power Consumption	W	10	10	10
Running Current	A	0.05	0.05	0.05
Dimensions	W x H x D	mm(inch) 302 x 143 x 252 (11.9 x 5.6 x 9.9)	mm(inch) 302 x 143 x 252 (11.9 x 5.6 x 9.9)	mm(inch) 302 x 143 x 252 (11.9 x 5.6 x 9.9)
Net Weight	kg/lb	4.8 / 10.6	4.9 / 10.8	5 / 11
Piping Connection (To Outdoor Unit)	Liquid	mm(inch) Ø9.52 (3/8)	mm(inch) Ø9.52 (3/8)	mm(inch) Ø9.52(3/8)
	Gas	mm(inch) Ø19.05 (3/4)	mm(inch) Ø19.05 (3/4)	mm(inch) Ø19.05(3/4)
Piping Connection (To Indoor Unit)	Liquid	mm(inch) Ø6.35 (1/4) x 2EA	mm(inch) Ø6.35 (1/4) x 3EA	mm(inch) Ø6.35 (1/4) x 4EA
	Gas	mm(inch) Ø9.52 (3/8) x 2EA	mm(inch) Ø9.52 (3/8) x 3EA	mm(inch) Ø9.52 (3/8) x 4EA
Accessories	Hanger (Bracket)	EA 4	EA 4	EA 4
	Screw	EA 8	EA 8	EA 8
	Manual	EA 1	EA 1	EA 1

※ For our policy of continuous product improvement, specification, design and features are subject to change without prior notice.  
 Note : 1. The piping connection must be suit the piping sizes of the indoor unit which will be connected. (If need, use the connector which is included in the indoor unit)  
 2. The BD should be installed inside the building.

# ACCESSORIES

## Y Branch and Branch Kit

### PMBL5620 (2 units) / PMBL1203F0 (3 units)



### Features

- Y Branch and Branch kit make Multi FDX installation much easier.
- Y Branch and Branch kit for both gas and liquid are provided.
- Insulation material is also provided for covering the branches.

### Application

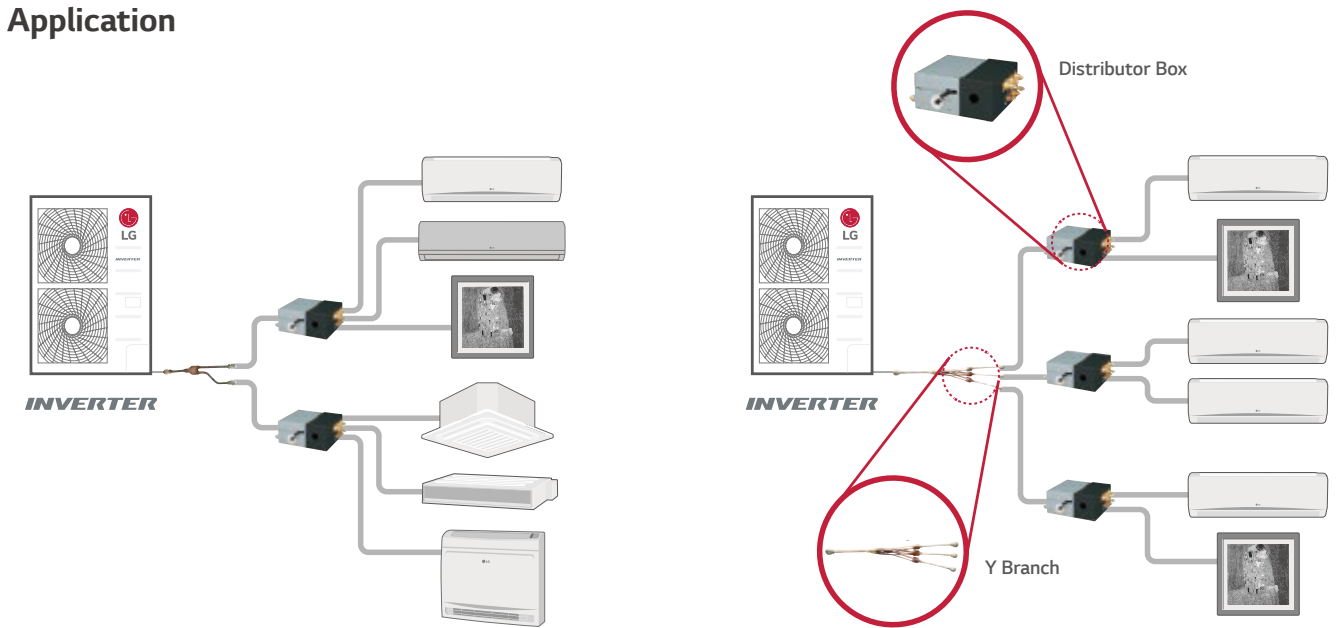

### Accessory Model Name

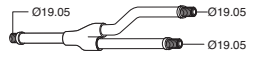
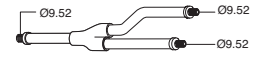
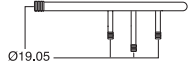
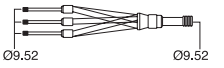
MODEL NAME	NO. OF BRANCH DISTRIBUTION UNITS	APPLICABLE MODEL	SPECIFICATION	
			GAS	LIQUID
PMBL5620	2 Units	1Ø, 3Ø		
PMBL1203F0	3 Units	1Ø, 3Ø		

# COMMERCIAL

SINGLE SPLIT



# LINE - UP

## H-INVERTER (R32)





















## STANDARD INVERTER (R32)

kBTu/h	Type kW	H-INVERTER (R32)				STANDARD INVERTER (R32)								
		Ceiling Mounted Cassette	Ceiling Concealed Duct Mid Static	Concealed Duct Low Static	Ceiling Suspended	ODU		Ceiling Mounted Cassette	Ceiling Concealed Duct Mid Static	Concealed Duct Low Static	Ceiling Suspended	Console / Wall Mounted	ODU	
						1Ø	3Ø						1Ø	3Ø
9	2.5													
12	3.4													
18	5.0													
24	6.8													
30	8.0													
36	9.5													
42	12.0													
48	13.4													  
60	14.6													
70	20.0													
85	25.0													

# LINE - UP

## COMPACT INVERTER (R32)

## STANDARD INVERTER (R410A)

kBTu/h	Type kW	COMPACT INVERTER (R32)					STANDARD INVERTER (R410A)				
		Ceiling Mounted Cassette	Ceiling Concealed Duct Mid Static	Concealed Duct Low Static	Ceiling Suspended	Wall Mounted	ODU	Ceiling Concealed Duct (High Static)	Floor Standing	ODU	
						1Ø			1Ø	3Ø	
9	2.5										
12	3.4										
18	5.0										
24	6.8										
30	8.0										
36	9.5										
42	12.0										
48	13.4										
60	14.6										
70	20.0										
85	25.0										

# SINGLE SPLIT

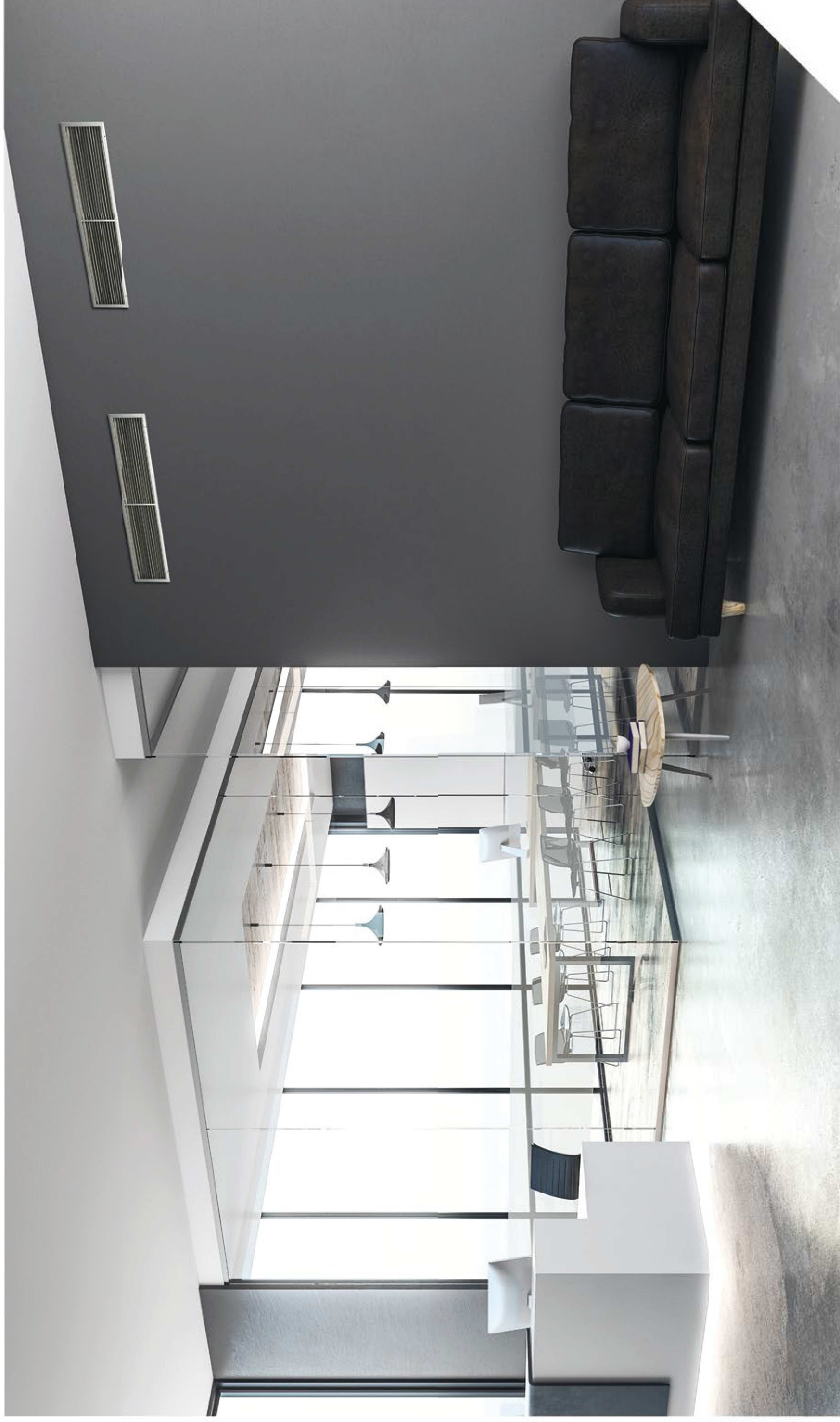

# FEATURE OVERVIEW

Category	H-Inverter (R32)									
	kBtu/h	9	12	18	24	30	36	42	48	60
	kW	2.5	3.4	5.0	6.8	8.0	9.5	12.0	13.4	14.6
<b>Supreme Energy Efficiency</b>	BLDC Comp. & Fan Motor	•	•	•	•	•	•	•	•	•
	Eurovent Certi.	•	•	•	•	•	•	•	•	•
	High Level SEER / SCOP	•	•	•	•	•	•	•	•	•
	Variable Voltage Control	•	•	•	•	•	•	•	•	•
	Wide Louver Fin	•	•	•	•	•	•	•	•	•
	Optimised Heat Exchanger Path			•	•	•	•	•	•	•
	Power Saving Start up	•	•	•	•	•	•	•	•	•
	Peak Current Control			•	•	•	•	•	•	•
	Mode Lock	•*	•*	•	•	•	•	•	•	•
	Standby Mode	•	•	•	•	•	•	•	•	•
<b>Comfort Environment</b>	Comfort Cooling with Humidity sensor**			•	•	•	•	•	•	•
	Night Silent Operation			•	•	•	•	•	•	•
	Continuous Cooling Operation	•	•	•	•	•	•	•	•	•
<b>High Performance &amp; Reliability</b>	Quick & Reliable Operation	•	•	•	•	•	•	•	•	•
	R1 Compressor						•	•	•	•
	Corrosion resistance Black Fin	•	•	•	•	•	•	•	•	•
	Long Pipe Installation	•	•	•	•	•	•	•	•	•
<b>Convenient Control System</b>	LG ThinQ***	•	•	•	•	•	•	•	•	•
	Easy control (PI-485 Connection)	•	•	•	•	•	•	•	•	•
	1 Point External Input****	•	•	•	•	•	•	•	•	•
	Forced Cooling Operation			•	•	•	•	•	•	•
	Mobile LG MV	•	•	•	•	•	•	•	•	•
	Weekly Program*****	•	•	•	•	•	•	•	•	•
<b>Enhanced Application</b>	Synchro function									
	Connection with AHU			•	•	•	•	•	•	•

\* With controller PREMTB001 / PREMTBB01 / PREMTB100 / PREMTBB10  
 \*\* Available only for Ceiling Mounted cassette (840 x 840), Ceiling Suspended, Console models.  
 \*\*\* Available with LG Wi-Fi modem(PWFMDD200) and it should be connected to the indoor unit  
 \*\*\*\* Available except for Wall Mounted Unit.  
 \*\*\*\*\* Weekly program is available with wired remote controller

Category	Standard Inverter (R32)									Compact Inverter (R32)				
	kBtu/h	9	12	18	24	30	36	42	48	60	18	24	30	36
	kW	2.5	3.4	5.0	6.8	8.0	9.5	12.0	13.4	14.6	5.0	6.8	8.0	9.5
<b>Supreme Energy Efficiency</b>	BLDC Comp. & Fan Motor	•	•	•	•	•	•	•	•	•	•	•	•	•
	Eurovent Certi.	•	•	•	•	•	•	•	•	•	•	•	•	•
	High Level SEER / SCOP	•	•	•	•	•	•	•	•	•	•	•	•	•
	Variable Voltage Control	•	•	•	•	•	•	•	•	•	•	•	•	•
	Wide Louver Fin	•	•	•	•	•	•	•	•	•	•	•	•	•
	Optimised Heat Exchanger Path				•	•	•	•	•	•		•	•	•
	Power Saving Start up	•	•	•	•	•	•	•	•	•	•	•	•	•
	Peak Current Control				•	•	•	•	•	•		•	•	•
	Mode Lock	•*	•*	•	•	•	•	•	•	•	•*	•	•	•
	Standby Mode	•	•	•	•	•	•	•	•	•	•	•	•	•
<b>Comfort Environment</b>	Comfort Cooling with Humidity sensor**	•	•	•	•	•	•	•	•	•	•	•	•	•
	Night Silent Operation			•	•	•	•	•	•	•		•	•	•
	Continuous Cooling Operation	•	•	•	•	•	•	•	•	•				
<b>High Performance &amp; Reliability</b>	Quick & Reliable Operation	•	•	•	•	•	•	•	•	•	•	•	•	•
	R1 Compressor							•	•	•				
	Corrosion resistance Black Fin	•	•	•	•	•	•	•	•	•	•	•	•	•
	Long Pipe Installation	•	•	•	•	•	•	•	•	•	•	•	•	•
<b>Convenient Control System</b>	LG ThinQ***	•	•	•	•	•	•	•	•	•	•	•	•	•
	Easy control (PI-485 Connection)	•	•	•	•	•	•	•	•	•	•	•	•	•
	1 Point External Input****	•	•	•	•	•	•	•	•	•	•	•	•	•
	Forced Cooling Operation				•	•	•	•	•	•		•	•	
	Mobile LG MV	•	•	•	•	•	•	•	•	•	•	•	•	•
	Weekly Program*****	•	•	•	•	•	•	•	•	•	•	•	•	•
<b>Enhanced Application</b>	Synchro function							•	•	•	•			
	Connection with AHU				•	•	•	•	•	•		•	•	•

\* With controller PREMTB001 / PREMTBB01 / PREMTB100 / PREMTBB10  
 \*\* Available only for Ceiling Mounted cassette (840 x 840), Ceiling Suspended, Console models.  
 \*\*\* Available with LG Wi-Fi modem(PWFMDD200) and it should be connected to the indoor unit  
 \*\*\*\* Available except for Wall Mounted Unit.  
 \*\*\*\*\* Weekly program is available with wired remote controller

# WHY LG SINGLE SPLIT?

## Triple Line-up for On-site Customization

LG's commercial triple line-up provides more customizable options for unique customer needs and installation requirements.



LINE-UP	DESCRIPTION	9K (2.5kW)	12K (3.4kW)	18K (5.0kW)	24K (6.8kW)	30K (8.0kW)	36K (9.5kW)	42K (12.0kW)	48K (13.4kW)	60K (14.6kW)
<b>H-INVERTER (R32)</b> SEER A+++ - A+	<b>High Performance</b> - Suitable for high quality functions - Maximum pipe length up to 85m* - Floor Detection Sensor (Default) - Wide Cooling operation range (-20°C - 52°C) & 100% Capacity at 48°C* - Wide Heating operation range (-25°C - 18°C) & 100% Capacity at -15°C*	UUA1	UUB1	UUC1					UUD1/3	
<b>STANDARD INVERTER (R32)</b> SEER A++ - A	<b>Wide Commercial Applications</b> - Suitable for wide commercial applications - Maximum pipe length up to 85m* - Synchro Function over 36k Model (Max. 4 IDUs) - Wi-Fi Modem and Floor Detection Sensor (Option) - Wide Cooling operation range (-20°C - 52°C)* - Wide Heating operation range (-25°C - 18°C)*	UUA1	UUB1	UUC1					UUD1/3	
<b>COMPACT INVERTER (R32)</b> SEER A+ - A	<b>Compact &amp; Cost Effective</b> - Suitable for busy environments and small shops - Very compact and easy to install - Maximum pipe length up to 50m* - Wi-Fi Modem and Floor Detection Sensor (Option) - Cooling operation range (-20°C - 50°C)* - Heating operation range (-15°C - 18°C)*			UUA1	UUB1	UUC1				

\* This specification can be different as per each model or combination.

### Application : Premium residences & office spaces Solution : H-Inverter



\* Based on maximum operation

**High Performance**

- High energy savings  
Seasonal efficiency class : A+++ - A+
- Powerful cooling & heating under harsh conditions\*
- Maximum pipe length up to 85m
- Comfort heating with floor sensor (with premium panel)
- Embedded Drain Pump
- Connection with AHU

※ The indoor unit functions is an example of cassette model.  
 ※ The specification can be different as per each model or combination.

### Application : Large restaurant & cafes Solution : Standard Inverter

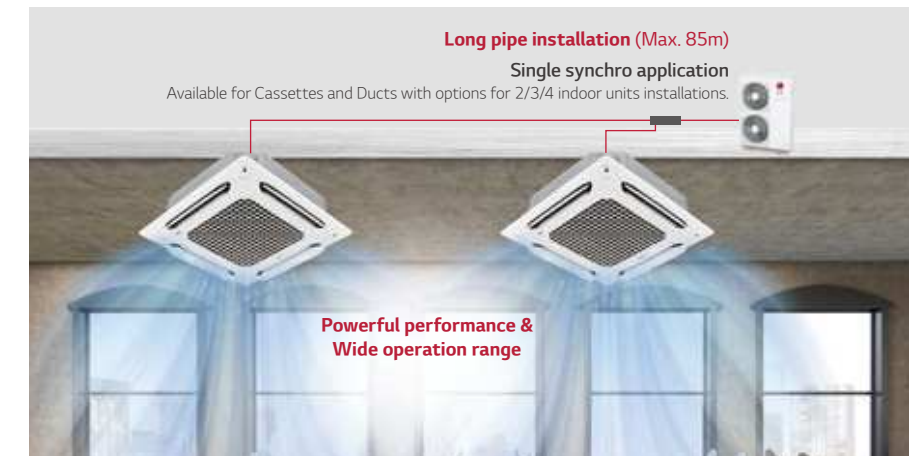

\* Accessories are ordered and purchased separately and installed at field.

**Wide commercial applications**

- Wide operation range  
Cooling (DB) : -20 - 52 °C  
Heating (WB) : -25 - 18 °C
- Maximum pipe length up to 85m
- Synchro Function over 36k Model (Max. 4 IDUs)
- Connection with AHU
- On-demand accessories\*  
Wi-Fi, Drain pump, human detection

※ The specification can be different as per each model or combination.

### Application : Small shops Solution : Compact Inverter

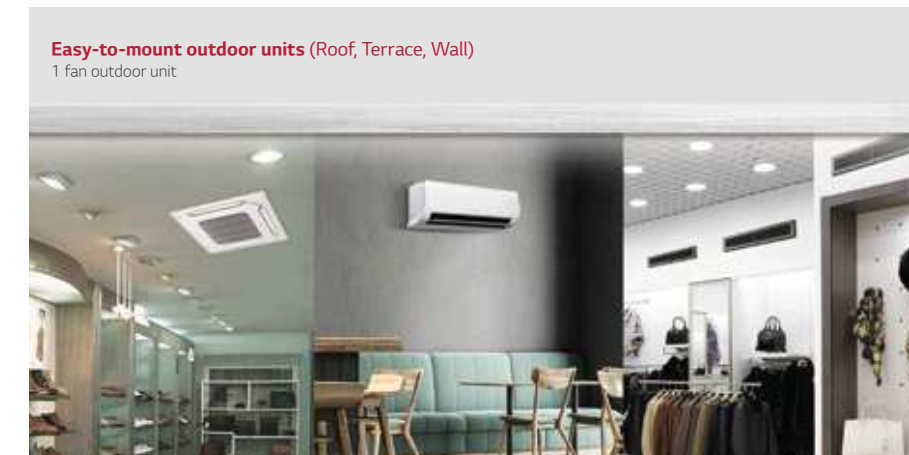

\* Accessories are ordered and purchased separately and installed at field.

**Compact & Cost Effective**

- Very compact and easy to install
- Maximum pipe length up to 50m
- Connection with AHU
- On-demand accessories\*  
Wi-Fi, Drain pump, human detection

※ The specification can be different as per each model or combination.



# WHY LG SINGLE SPLIT?

## Free Combination

By applying concept of free combination, the total line-up increases from 45 to 93 sets while number of outdoor unit is decreased from 17 EA to 5 EA.

**PREVIOUS (FIXED COMBINATION)**

Separated outdoor unit

Capacity	Standard	Compact
9K	UU09WR	
12K	UU12WR	
18K	UU18WR	UU18WCR
24K	UU24WR	UU24WCR
30K	UU30WR	UU30WCR
36K	UU36WR UU37WR	UU36WCR
42K	UU42WR UU43WR	
48K	UU48WR UU49WR	
60K	UU60WR UU61WR	

Total 17 model

**NEW (FREE COMBINATION)**

Separated outdoor unit

Capacity	Standard	Compact
9 / 12K	UUA1	UUA1
18K	UUB1	UUB1
24 / 30K	UUC1	UUC1
36K	UUD1/3	UUC1
48 / 60K	UUD1/3	

Total 5 model

LINE UP	CST	DUCT	CVT	OTHERS	TOTAL
High	-	-	-	-	-
Standard	13	15	11	1	40
Compact	-	4	-	1	5
Total	13	19	11	2	45

→ Total Line-up is increased from 45 to 93 sets

LINE UP	CST	DUCT	CVT	OTHERS	TOTAL
High	13	12	7	-	32
Standard	13	15	11	6	45
Compact	4	6	4	2	16
Total	30	33	22	8	93

## Expanded Product Type

LG Single split expands from double to triple line-up including various types of indoor units.

CAPACITY	H-INVERTER (R32)				STANDARD INVERTER (R32)				COMPACT INVERTER (R32)					
	Cassette	Duct Mid Static	Duct Low Static	Ceiling Suspended	Cassette	Duct Mid Static	Duct Low Static	Ceiling Suspended	Console / Wall Mounted	Cassette	Duct Mid Static	Duct Low Static	Ceiling Suspended	Wall Mounted
9k	UT09FH			<b>NEW!</b>	CT09F		CL09F		UQ09F					
12k	UT12FH	UM12FH	UL12FH		CT12F		CL12F		UQ12F					
18k	UT18FH	UM18FH	UL18FH	UV18FH	CT18F	CM18F	CL18F	UV18F	UQ18F	<b>NEW!</b>	CM18F	CL18F	UV18F	<b>NEW!</b>
24k	UT24FH	UM24FH		UV24FH	CT24F	CM24F	CL24F	UV24F		CT24F	CM24F	CL24F	UV24F	
30k	UT30FH	UM30FH		UV30FH	UT30F	UM30F		UV30F	US30F	UT30F	UM30F		UV30F	US30F
36k	UT36FH	UM36FH		UV36FH	UT36F	UM36F		UV36F	US36F	UT36F	UM36F		UV36F	US36F
42k	UT42FH	UM42FH		UV42FH	UT42F	UM42F		UV42F						
48k	UT48FH	UM48FH			UT48F	UM48F		UV48F						
60k	UT60FH				UT60F	UM60F		UV60F						

Common ODU

UUA1	UUB1	UUC1	UUD1 (1Φ) UUD3 (3Φ)
770 x 545 x 288	870 x 650 x 330	950 x 834 x 330	950 x 1380 x 330

## Differentiated Specification

LG Single Split provides differentiated features (performance/installation/convenience) with each product line.

Items	H-INVERTER	STANDARD	COMPACT	19Y Standard (R32)
	High Performance	Wide commercial applications	Compact & Cost Effective	
SEER Class	A+++ ~ A+	A++ ~ A+	A++ ~ A	A++ ~ A+
Cooling Capacity* @48°C	112%	105%	88%	100%
Heating Capacity* @-15°C	124%	107%	98%	100%
Operation Range (Cooling, DB)	-20 ~ 50 °C		-10 ~ 48 °C	-15 ~ 48 °C
Operation Range (Heating, WB)	-20 ~ 18 °C		-15 ~ 18 °C	-18 ~ 18 °C
Max. Pipe Length	50 m		35 m	50 m
Cooling Capacity @50m	113%	109%	-	100%
Drain Pump (Cassette)	●	●	●	●
Drain Pump (Duct, Suspended)	●	Accessory	Accessory	Accessory
Humidity Control (cassette, suspended, console)	●	●	●	●
Wi-Fi (Cassette)	Accessory	Accessory	Accessory	Accessory
Floor Detection (Cassette)	●	N/A	N/A	N/A
Air purifying (Cassette)	Accessory	N/A	N/A	N/A
Human detection (Cassette)	Accessory	Accessory	Accessory	Accessory
Synchro Application	N/A	36k ↑	N/A	36k ↑
AHU Comm. Kit Application	18k ↑	18k ↑	24k ↑	18k ↑

\* Based on internal test data for 9.5kW model. (Capacity is calculated compared to 19Y standard model)  
 ※ This specification can be different as per each model or combination.  
 ※ In the case of cassette model, note that the function depends on the application of recommended decoration panel.

# SUPREME ENERGY EFFICIENCY

## SEER / SCOP

LG's advanced technologies achieve world-class energy efficiency.



### SEER / SCOP class

kW	2.5	3.4	5.0	6.8	8.0	9.5	Average
SEER	7.0	6.8	7.6	8.5	7.8	7.6	7.6
	A++	A++	A++	A+++	A++	A++	A++
SCOP	4.0	4.0	4.4	4.8	4.8	4.5	4.4
	A+	A+	A+	A++	A++	A+	A+

※ These values are based in the H-Inverter Ceiling Cassette model and can change based on the applied combination.

### European Energy Labeling

	SEER	SCOP
A+++	SEER ≥ 8.5	SCOP ≥ 5.1
A++	6.1 ≤ SEER < 8.5	4.6 ≤ SCOP < 5.1
A+	5.6 ≤ SEER < 6.1	4.0 ≤ SCOP < 4.6
A	5.1 ≤ SEER < 5.6	3.4 ≤ SCOP < 4.0
B	4.6 ≤ SEER < 5.1	3.1 ≤ SCOP < 3.4
C	4.1 ≤ SEER < 4.6	2.8 ≤ SCOP < 3.1
D	3.6 ≤ SEER < 4.1	2.5 ≤ SCOP < 2.8

\* Based on Ceiling Cassette (6.8 kW)

# SUPREME ENERGY EFFICIENCY

## Energy Savings

LG commercial air conditioners will automatically alter the temperature of discharge air by controlling their refrigerant temperature based on the difference between the indoor temperature and the target indoor temperature. During cooling operation, evaporating temperature will increase if the temperature difference reduces. This allows for enhanced comfort and reduced energy consumption.

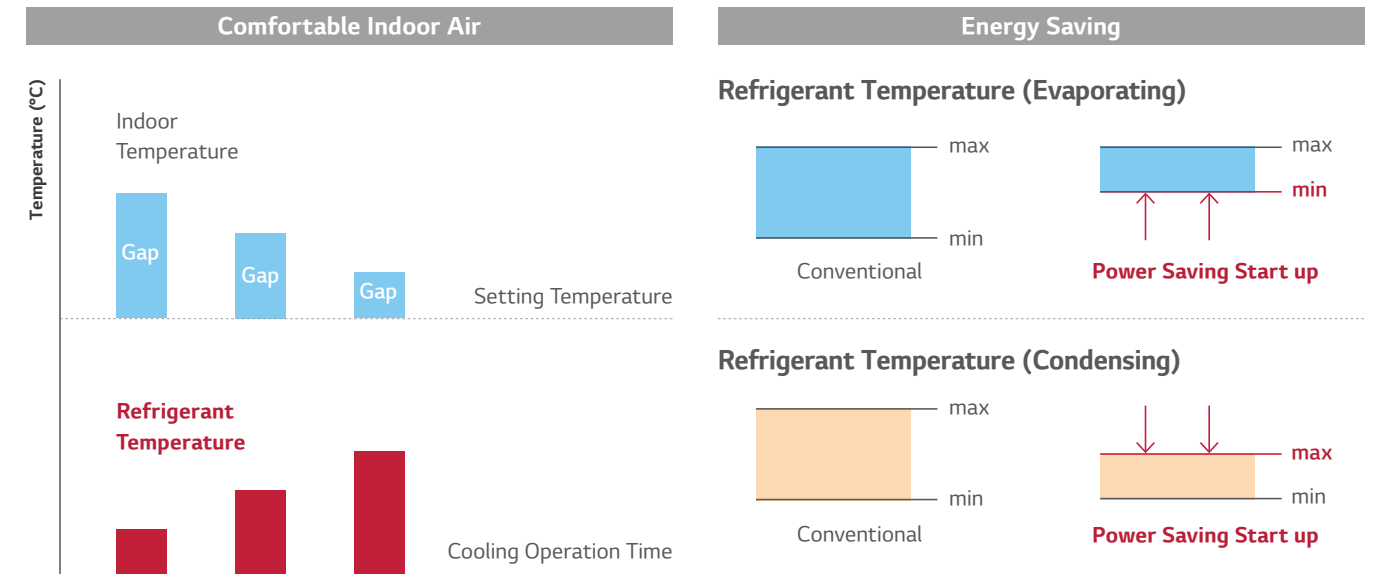

## Peak Current Control

The peak current control function prevents the air conditioner from running at the maximum level while maintaining current system settings, in order to reduce energy consumption. This function helps minimize energy costs during the peak periods of energy use when the energy billing is much higher.

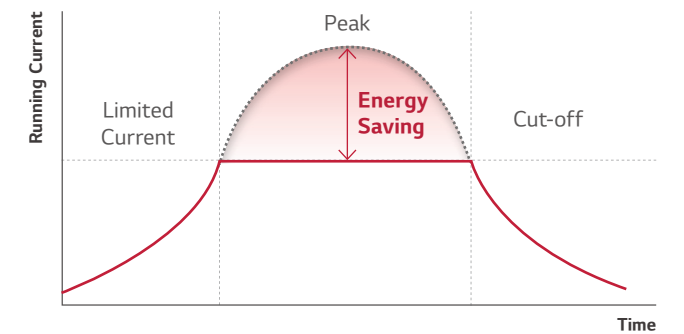

## Mode Lock

Set the operation mode to either cooling-only or heating-only; either by adjusting the wired remote controller or setting the DIP switch to avoid combined use of cooling and heating. (Some models need wired remote controller for mode lock function according to feature overview table)

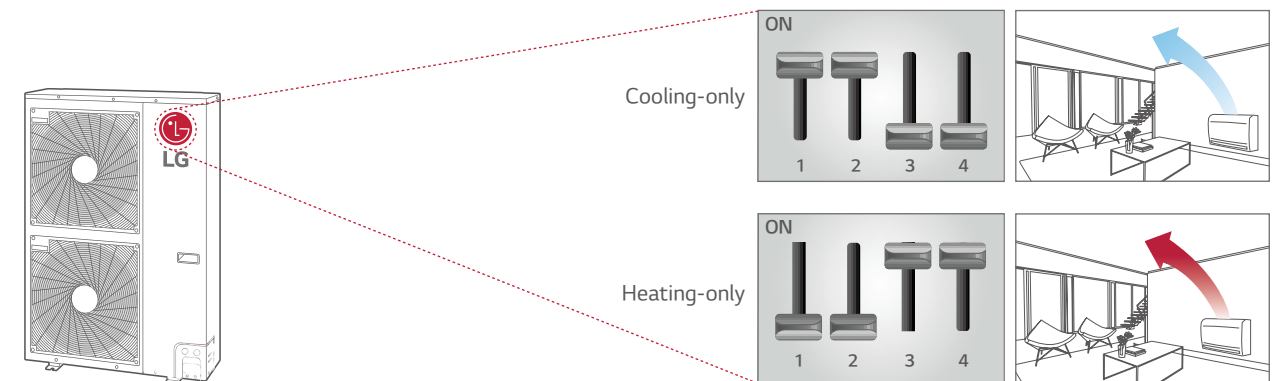

# COMFORTABLE ENVIRONMENT

## Comfort with Temperature & Humidity Sensors

With Dual Sensing Control, air conditioners can rapidly achieve a comfortable indoor environment for customers.



By sensing both temperature and humidity, this feature helps avoid over-cooling and dehumidification, maximizing comfort



※ Comfort cooling apply to Ceiling Cassette, Ceiling Suspended, Console  
- It does not apply to small capacity cassette models  
(UT09FH, UT12FH, CT09F, CT12F, CT18F)

### Dry Summer

During a dry summer season, the system senses the low humidity levels and decreases the operating ratio to increase humidity for a more comfortable environment and energy efficient operation.

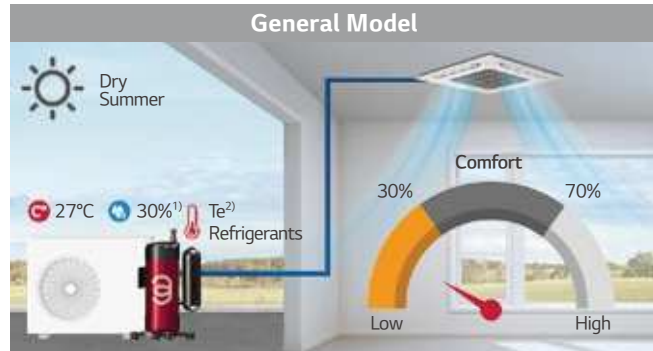

- **Uncomfortable Environment**  
Excessive latent heat elimination regardless of humidity
- **Waste Energy**  
Eliminate latent heat unnecessarily

### Wet Summer

During a wet summer season, the system senses the high humidity levels and increases the operating ratio to rapidly decrease humidity for a more comfortable indoor environment.

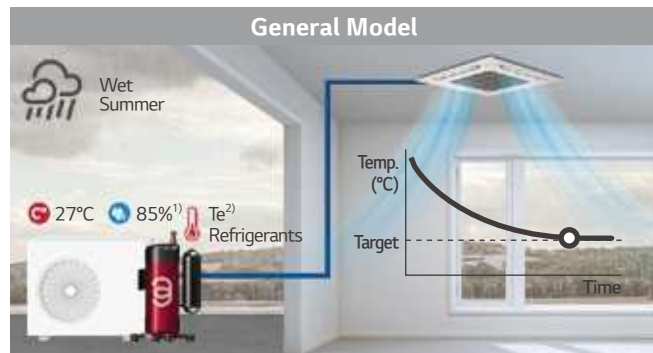

- **Uncomfortable Environment**  
General latent heat elimination regardless of humidity

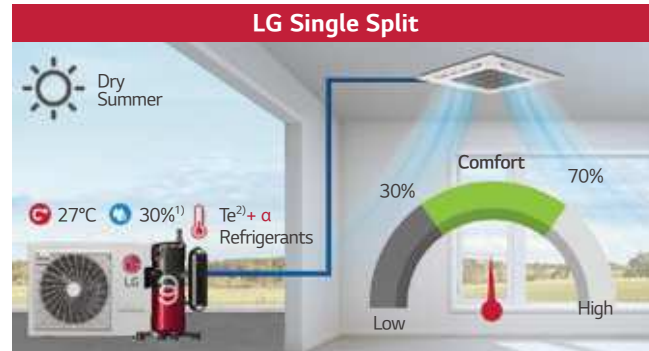

- **Comfortable Environment**  
By making the room less dry
- **Increased Energy Efficiency**  
Provide optimized cooling and save energy considering humidity  
Humidity Condition : Low (<30%), Standard (30~70%)  
1) Indoor Condition 2) Evaporation Temperature

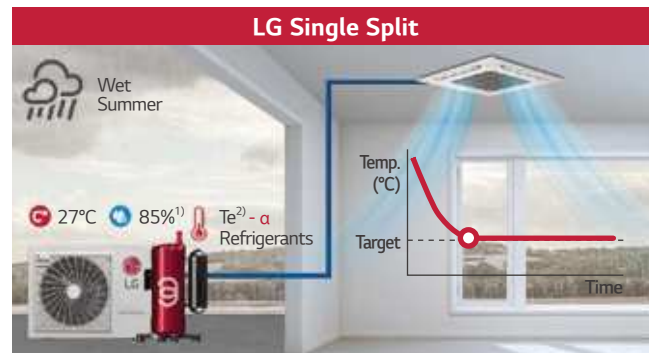

- **Comfortable Environment**  
Quick latent heat elimination with humidity sensors  
1) Indoor Condition 2) Evaporation Temperature

# COMFORTABLE ENVIRONMENT

## Night Silent Operation

Night Silent Operation can reduce noise levels at night time by simply setting the dip switch on the PCB of the outdoor unit.



※ Refer to the install manual for details.  
(Setting method, operation time)

\* The value is based on 14.6kW model.

## Continuous Cooling Operation

LG Single Split is able to perform continuous cooling at low ambient temperature (as low as -15°C)

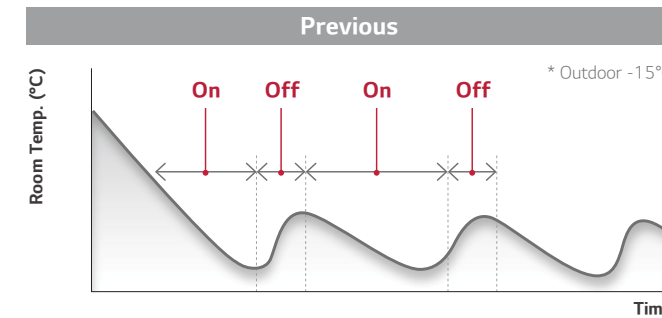

\* Based on a stand 36k model (before 2019)

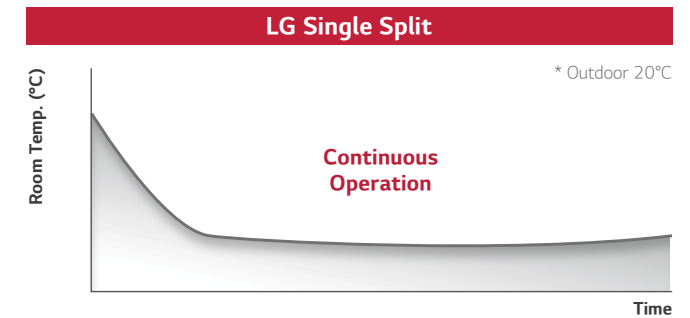

\* Based on a stand 36k model (after 2019)

# HIGH PERFORMANCE & RELIABILITY

## Quick & Reliable Operation

Through pressure and temperature sensing, the desired indoor temperature can be reached more rapidly.

- Quick response due to sensing with ready for operation.
- Target performance point is reached while avoiding compressor damage from liquid compression or oil shortage.

- With pressure sensing, the desired temperature is achieved in 30% less time in cooling and 44% in heating.

### Temperature Sensor Only

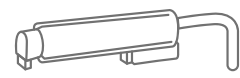

Temperature Sensor

Sensing → Estimating Pressure

It takes more time / Lack of reliable



### Smart Sensor

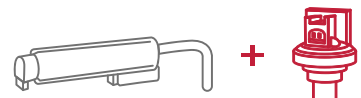

Temperature Sensor + Pressure Sensor

Directly Sensing refrigerant pressure → Operate Compressor

Quick and reliable operation

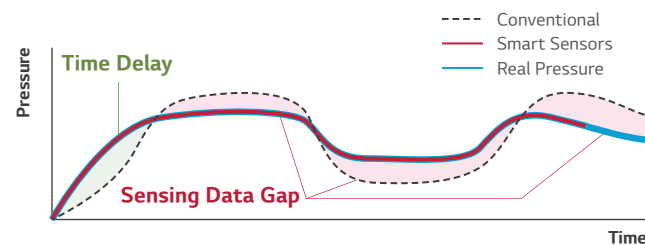

### • Cooling

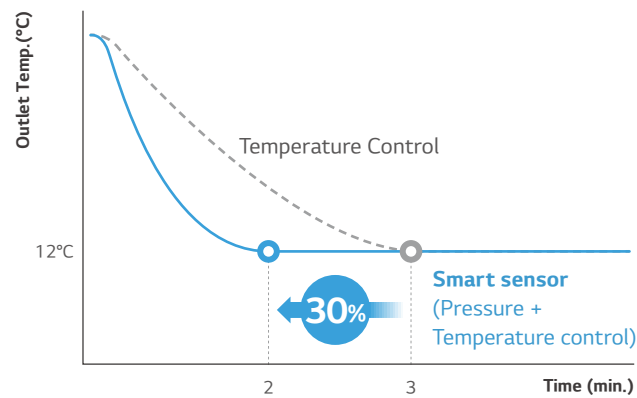

### • Heating

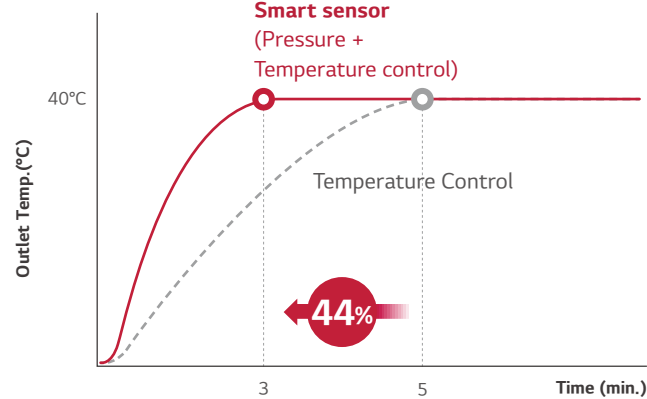

# HIGH PERFORMANCE & RELIABILITY

## R1 Compressor™

R1 Compressor is one that combines high-efficiency, low sound characteristics of the scroll and the simple compressing structure of the rotary compressor. This technology enables a highly efficient compact model.

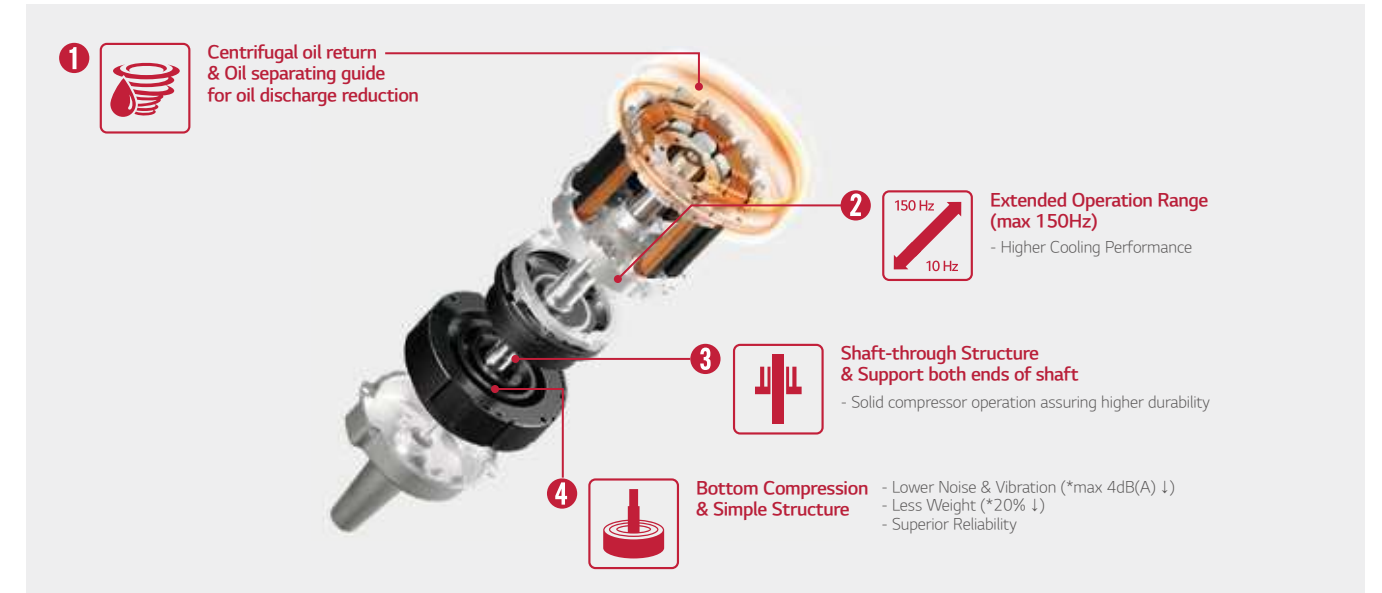

### Conventional Compressor

Scroll : High efficiency / Low sound (Continuous compression, but complex structure)

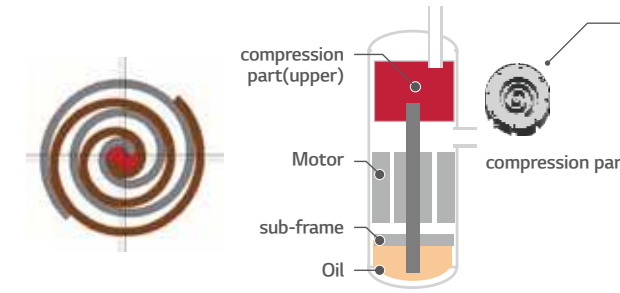

Rotary : Simple structure (Compression per 1 rotation)

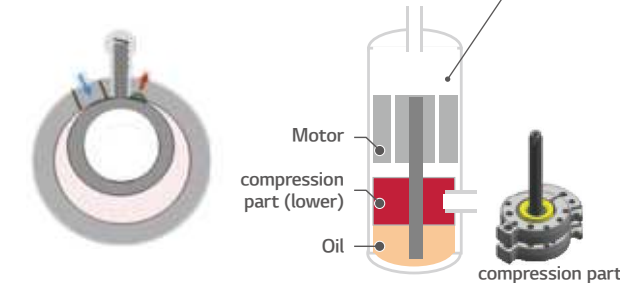

### R1 Compressor™

Revolutionary Scroll : High efficiency / Stable & Simple Structure

#### Hybrid Scroll Shape

(LG patent)\*  
\* Patent registration number (S.Korea : 10-1059880, USA : RE46106)

#### Motor

#### Compression parts (upper → lower)

Scroll penetrated by shaft → remove tilting moment

#### Simple structure : without sub-frame

Oil feeding structure better than previous scroll

#### Oil



Extended operation (Max. 150Hz)  
Low noise & Vibration (Max. 4dB(A)↓)  
Less weight (20%↓)

# HIGH PERFORMANCE & RELIABILITY

## Corrosion Resistance Black Fin

The black coating with enhanced epoxy resin is applied for strong protection from various corrosive external conditions such as salt contamination and air pollution including fumes from factories.

**Longer Lifespan, Lower Maintenance Costs**

- Hydrophilic Film (Water Flow)**  
The Hydrophilic coating minimizes moisture buildup on the fin.
- Acryl + Epoxy + Melamine Resin (Corrosion Resistant)**  
The Black coating provides strong protection from corrosion.
- Aluminum Fin**

Note: Product is not fully treated for anti-corrosion. To install near the sea, additional treatment must be required.

### SST (Salt Spray Test)

Test Process

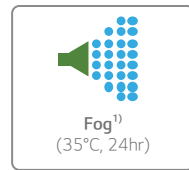

× Process repeated

Test process is conducted according to ISO 9227.  
1) Salty water concentration : NaCl aqueous solution (5%)

Test Result (5% Area of defects compared to initial)

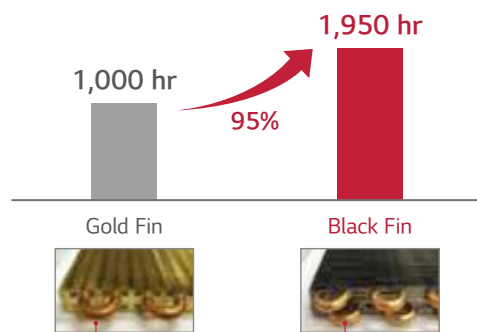

100% copper material to prevent corrosion & refrigerant leakage

### CCT (Cyclic Corrosion Test)

Test Process

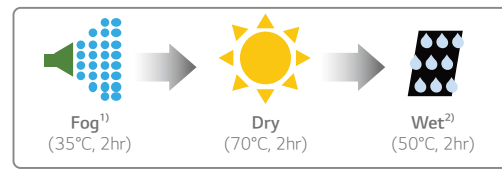

× Process Repeated

Test process is conducted according to ISO 14933.  
1) Salty water concentration : NaCl aqueous solution (5%)  
※ Dry condition changed : 60°C, 4hr → 70°C, 2hr  
2) Deionized water

Test Result (5% Area of defects compared to initial)

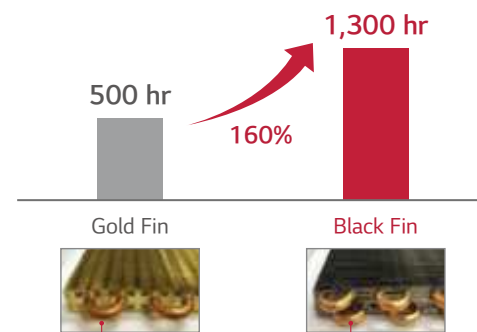

100% copper material to prevent corrosion & refrigerant leakage

# HIGH PERFORMANCE & RELIABILITY

## Long Pipe Installation

Maximum pipe length up to 85m and elevation length up to 30m provides flexibility for various conditions and easy installation.

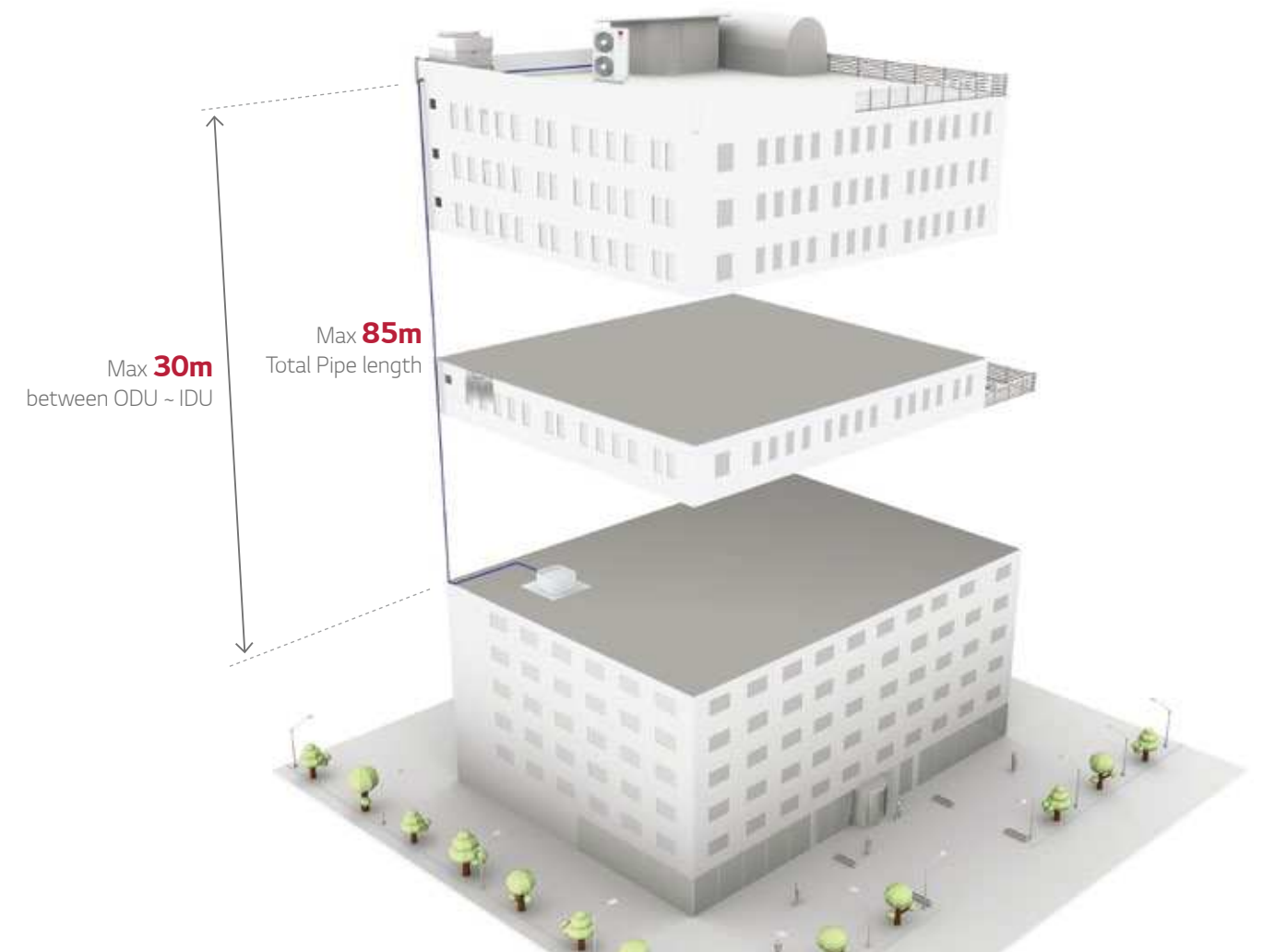

[Test condition]

- Location : LG HQ
- Installation : Apply the maximum pipe length by model
- Period : 3 month (checking oil level in real time)
- No use U-Trap

Model name	UUA1	UUB1	UUC1	UUD1 / UUD3
Total pipe length (m)	30	30 / 35*	50	85
Pipe Elevation Level ODU-IDU (m)	30	30	30	30

\* 24k, 30k

# CONVENIENT CONTROL SYSTEM

## LG ThinQ®

Users can control air conditioners using Android or iOS-enabled smartphones and voice commands via Google assistant and Amazon's Alexa.



※ Search "LG ThinQ" on Google or Apple store then download the app.  
 ※ Wi-Fi modem (PWFMD200) is required by option.

### Access your air conditioner anytime and from anywhere



### Simple operation for various functions

- On/Off\*
- Mode Selection\*
- Current temperature\*
- Set temperature\*
- Set fan speed\*
- Vane Control

\* This functions are used by google assistant & amazon alexa  
 ※ In some countries, the use of the google assistant & amazon alexa system may be restricted.  
 - Launched country : Germany, UK, Ireland, Austria, Switzerland, France, Spain, Italy, Russia, Norway, Netherland, Portugal, Turkey, Sweden, Denmark

## Easy Control (Central Controller)

PI-485 is a gateway device that provides communication between LG Outdoor Units and LG central controllers such as ACP, AC Smart.

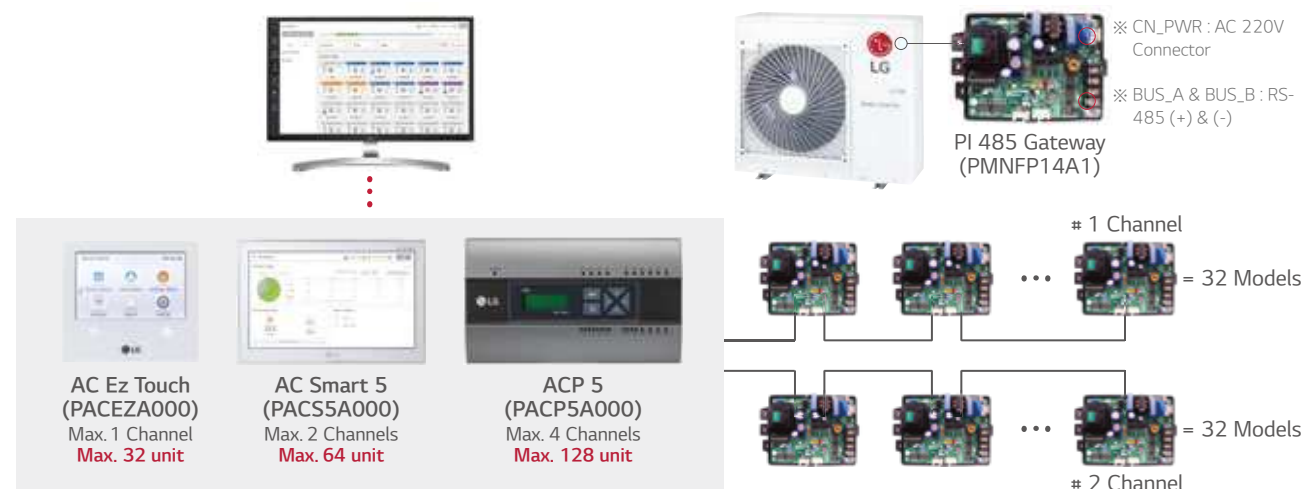

# CONVENIENT CONTROL SYSTEM

## 1 Point External Input (On / Off Control)

Indoor unit can be controlled by external devices without dry contact, so customer can save cost of installation.

Connection between an indoor unit and external devices directly

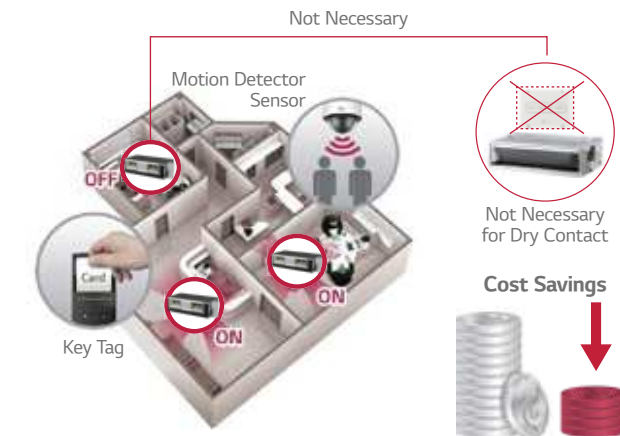

\* In case of needing more functions beside on / off control, a dry contact is required to be installed.

## Forced Cooling Operation

This function allows the refrigerant to be recharged or pumped down, regardless of the indoor temperature. Note that this function can be used when indoor units are being moved or repaired.

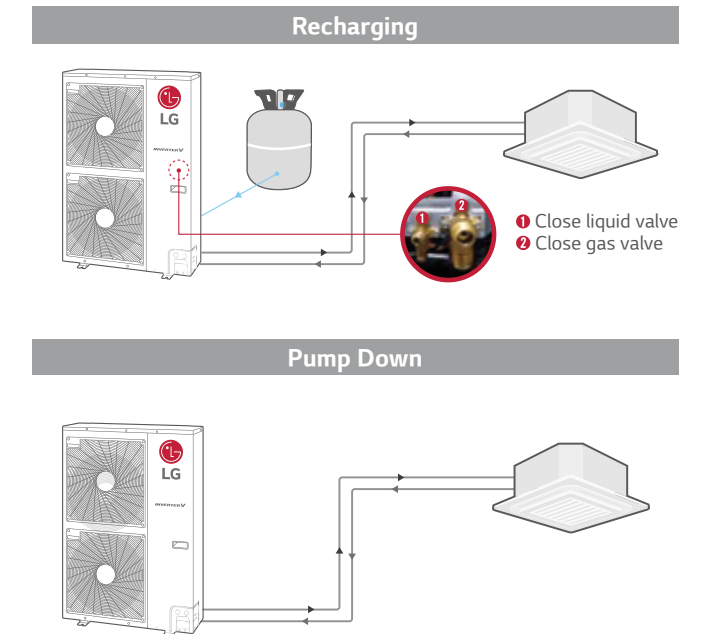

## Mobile LGMV

LGMV (Monitoring View) helps engineers to inspect and monitor air conditioning unit easily.

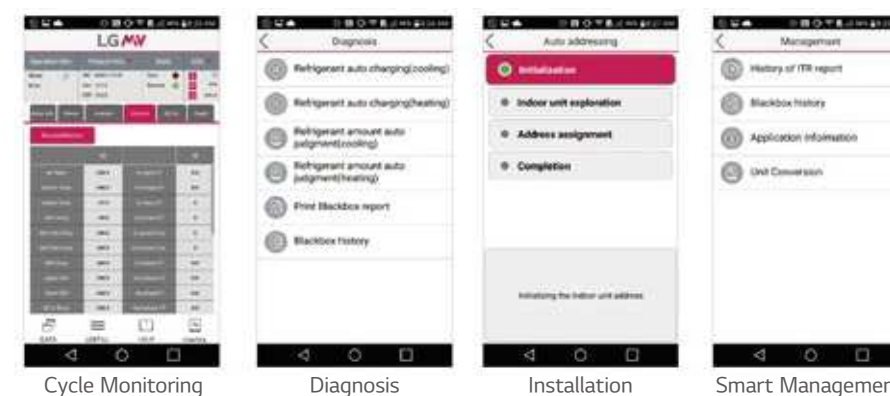

※ Search "Mobile LGMV" on Google or Apple store then download the app.  
 ※ Wi-Fi modem (PWFMD200) is required by option.

### Error Indicator

Contents	
01	Air temperature sensor of indoor unit
02	Inlet pipe temperature sensor of indoor unit
03	Communication error : Wired Remote Controller ↔ Indoor Unit
⋮	

→ A technician not only can check the cycle information with diagrams & graph, but also check easily the error status (troubleshooting guide) and take action immediately.

# ENHANCED APPLICATION

## Synchro function

Maximum 4 indoor units can be combined by using a branch kit and setting dip switch for one outdoor unit. It can be easily applied to various sites.

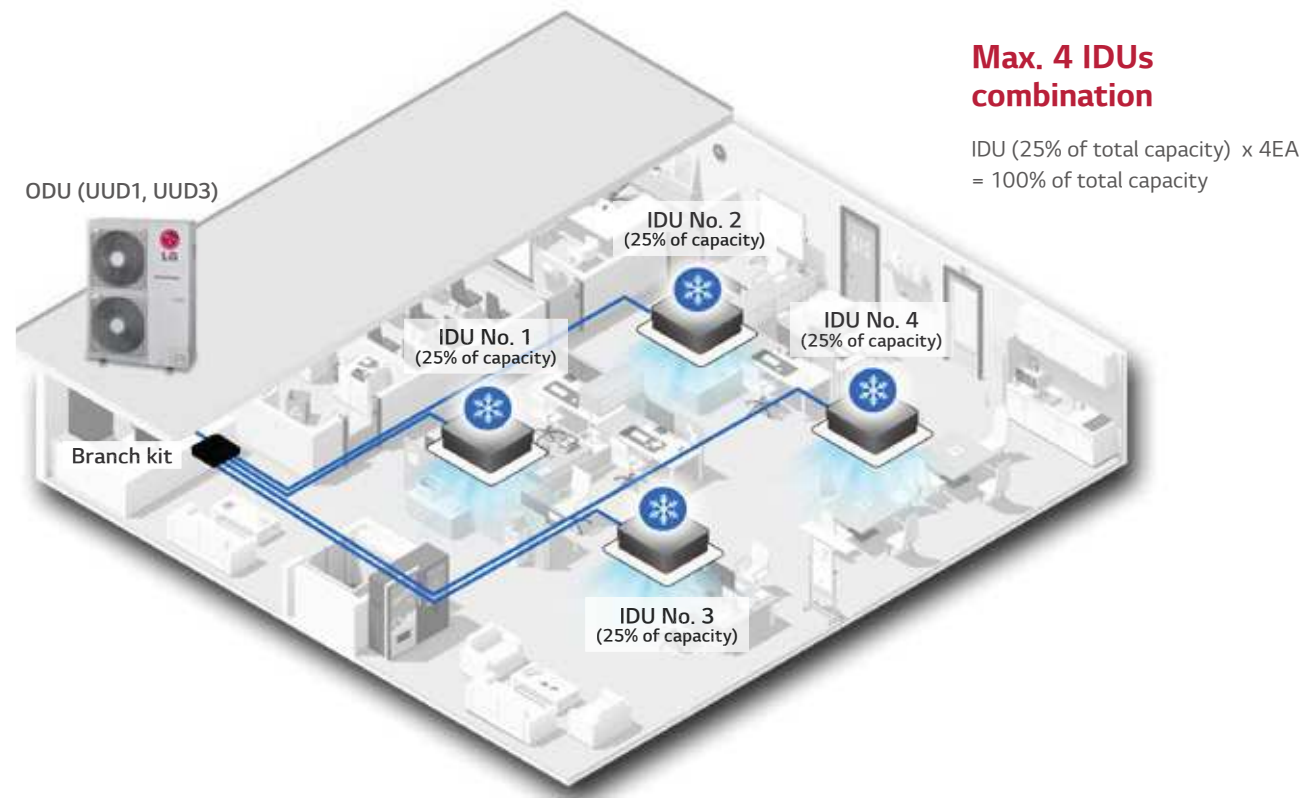

※ Combination table

Model	Duo		Trio		Quartet	
	Cassette	Duct	Cassette	Duct	Cassette	duct
UUD1, UUD3	CT18F x 2EA CT24F x 2EA UT30F x 2EA	CM18F x 2EA CM24F x 2EA UM30F x 2EA	CT12F x 3EA CT18F x 3EA	CL12F x 3EA CM18F x 3EA	CT12F x 4EA	CL12F x 4EA
Branch kit	PMUB11A		PMUB111A		PMUB1111A	
Dip switch						

Note

- Possible indoor units: Single CAC indoor unit series
  - Dry contact & Zone control & Auto changeover is not available which is connected with synchro.
  - When using synchro operation
    - Do not use wireless remote controller
    - Use only one wired remote controller in the indoor units.
    - Some Central controllers and some functions of central controller can not be available with synchro operation.
- Branch kits are required for operating Synchro models.

# ENHANCED APPLICATION

## Connection with AHU

Single split can be connected to AHU using communication kit.

**SIMPLE** **COMPLICATED**

Simple and space saving  
 Easy installation  
 Low maintenance cost

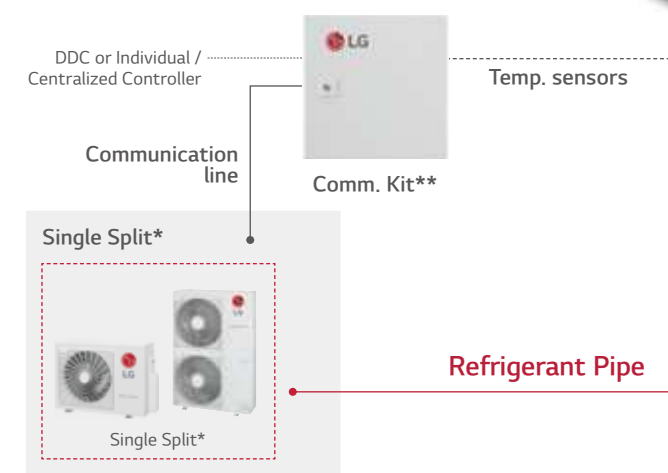
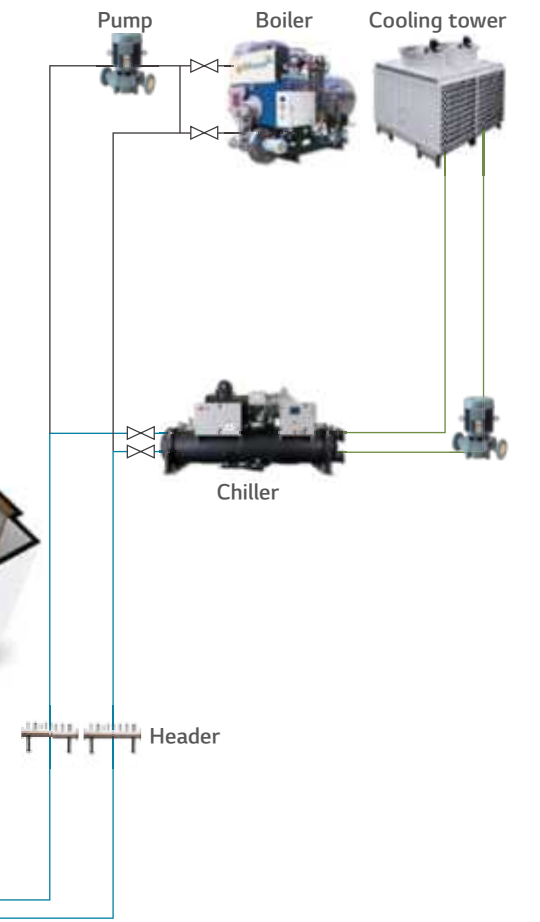
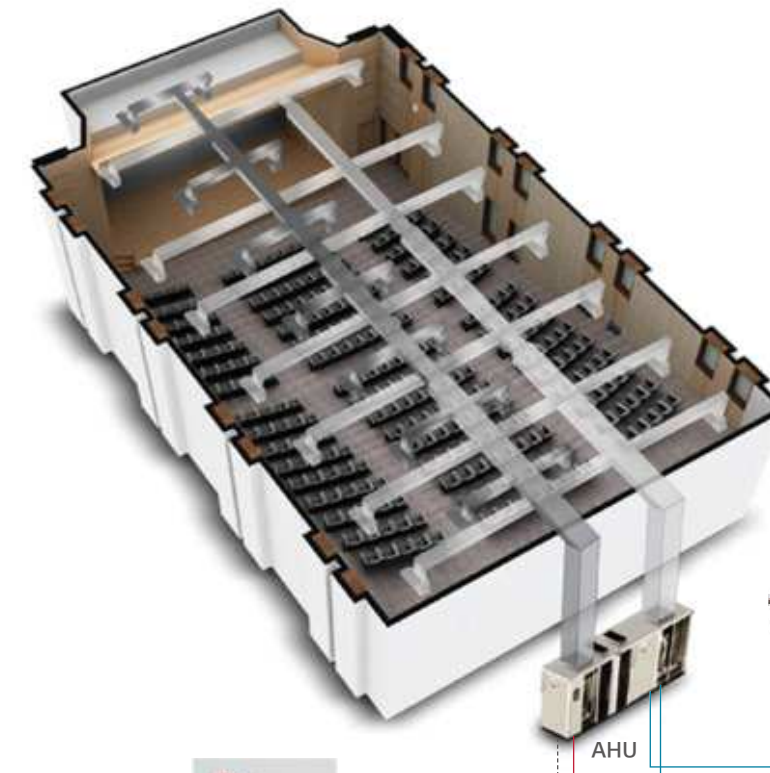

Complicated piping work

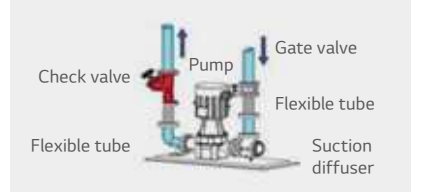

\* The single model can be applied only to UUB1, UUC1, UUD1, UUD3

\*\* Model name of communication kit  
 - RA air temperature control : PAHCMR000  
 - SA air temperature control : PAHCMS000

# CEILING MOUNTED CASSETTE



## NEW DESIGN

### 4-way air flow with new dual vane design

Innovative dual vane designs each of the best airflow over various spaces.



#### New types wind

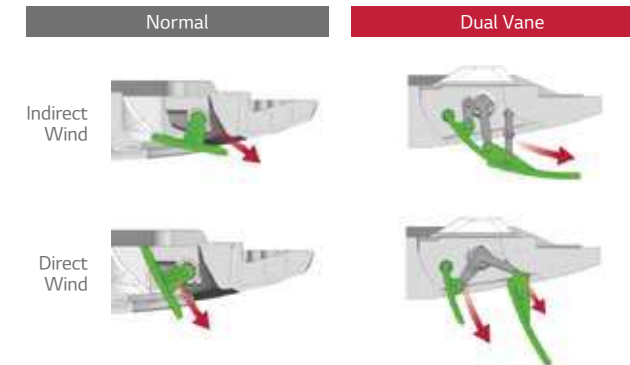

#### 6 air flow modes



### Brighter Color

Color enhancement allows cassette to blend in to most interior ceiling spaces.

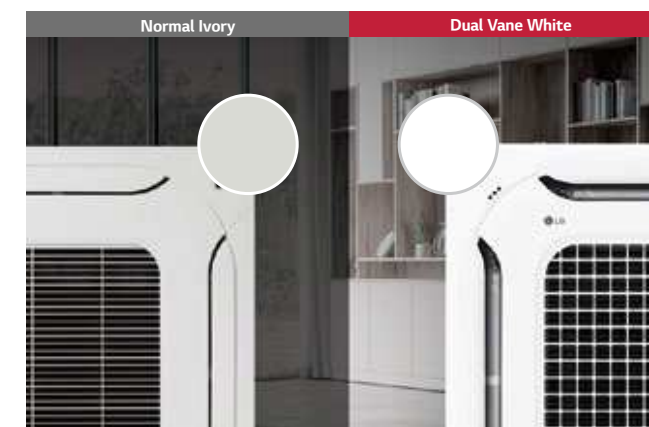

### Wide Design

Bigger inlet and outlet make faster cooling / heating airflow.

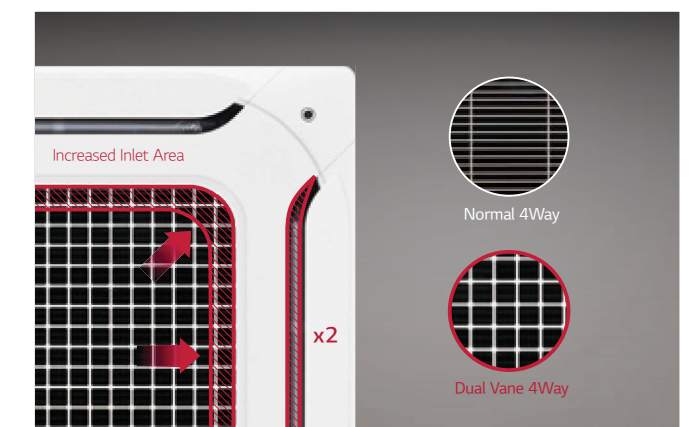



# NEW DESIGN

## Full 3D Turbo Fan

Full 3D Turbo fan decreases air resistance, so it makes High Efficient and reduces noise level.



## High Efficiency Heat Exchanger (HEX)

Highly integrated heat exchanger is applied to increase cooling and heating efficiency.

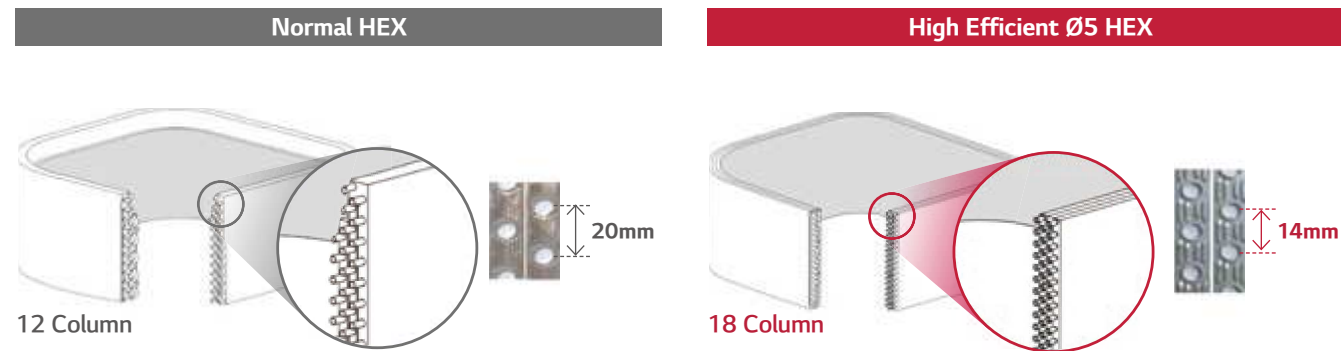

Tube Column	12 Column
Fin per Inch	21

※This specification can be different as per each model.

Tube Column	18 Column
Fin per Inch	22

# SMART

## Sensor reads temperature from ceiling to floor for heating

IDU provides the human oriented room temperature with sensing floor And calculating by floor and ceiling temperature by thermopile Sensor



※ Available only for products with floor temperature sensor.

## Human detecting Direct / Indirect airflow

Human sensing function finds users to provide their favorite airflow.

**Comfort Indirect**  
Prevent airflow to heading to user by sensing.



No touch  
Indirect airflow  
Comfort

**Follow user Direct**  
Prefer air flow to heading to user by sensing.



Direct airflow  
2°C  
Cooler

# SMART

## Human detecting ON/OFF Learning operation system

IDU senses people to switch ON/OFF for Max. 54% power saving.

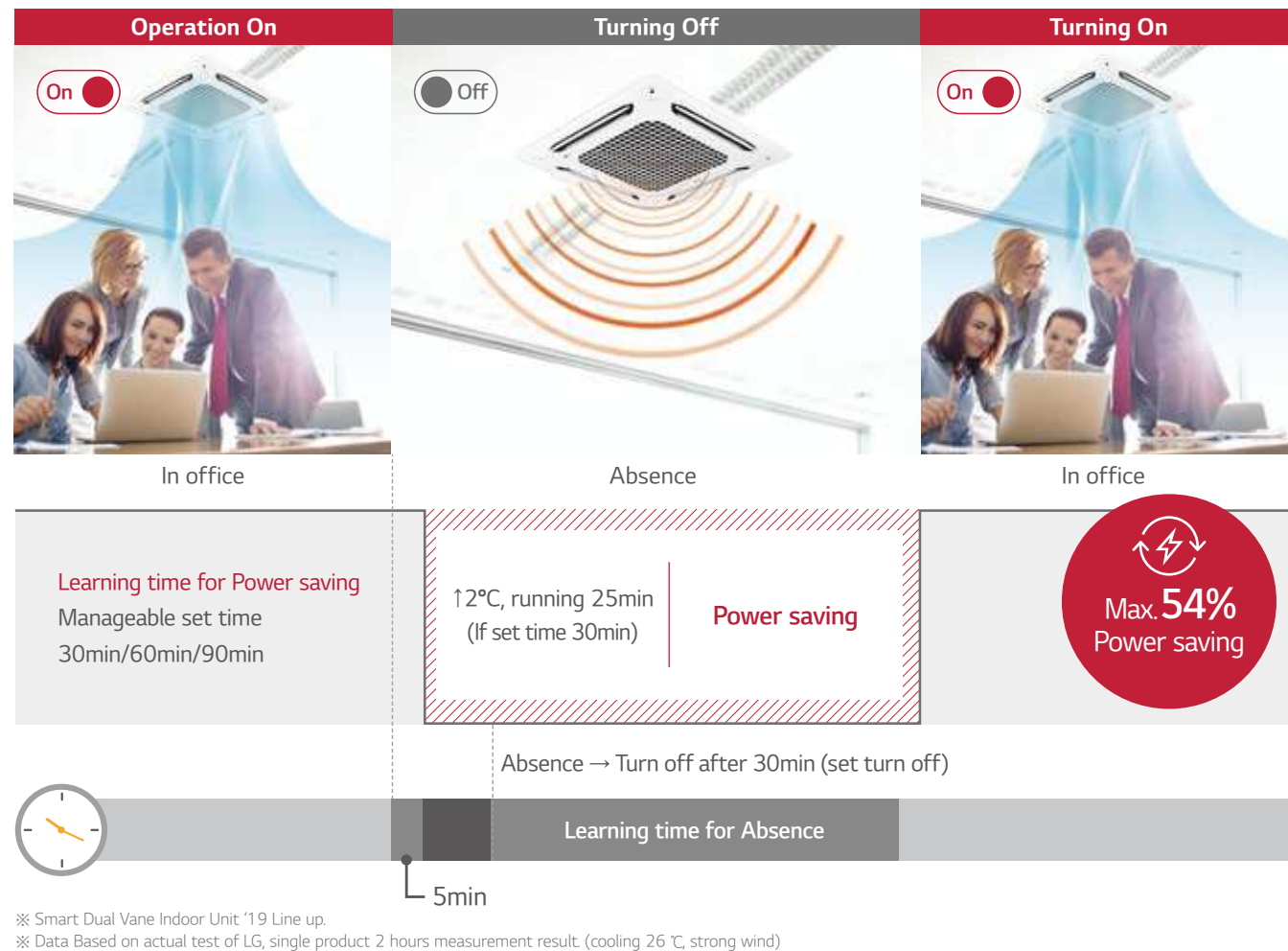

## Elevation Grill

4 lines of elevation grille contributes stable movement and convenient filter management.

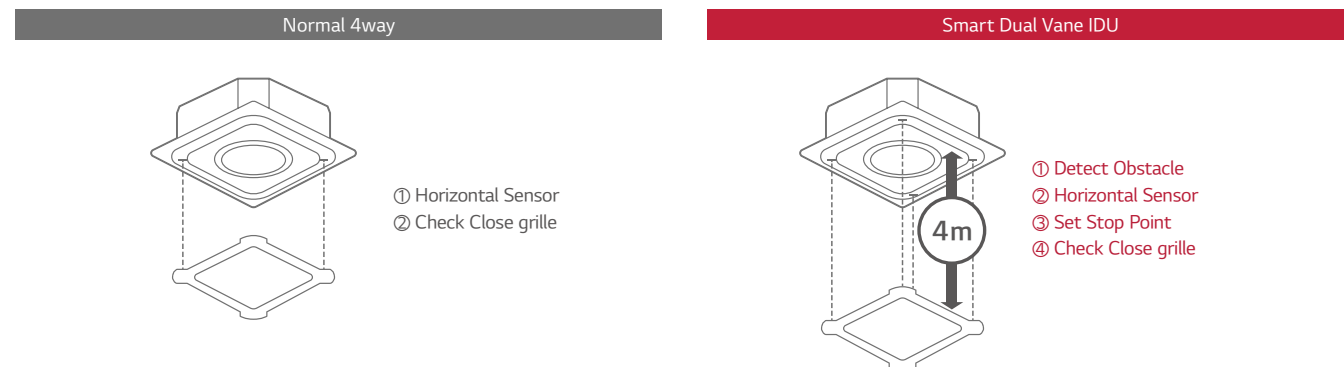

# SMART

## Everyday High performance of Air purifying

Air purifying function makes clean spaces for everyday.



## Convenient and Powerful 4 Steps Air purifying

Easy to manage air purifying system with one-touch air cleaning filter.

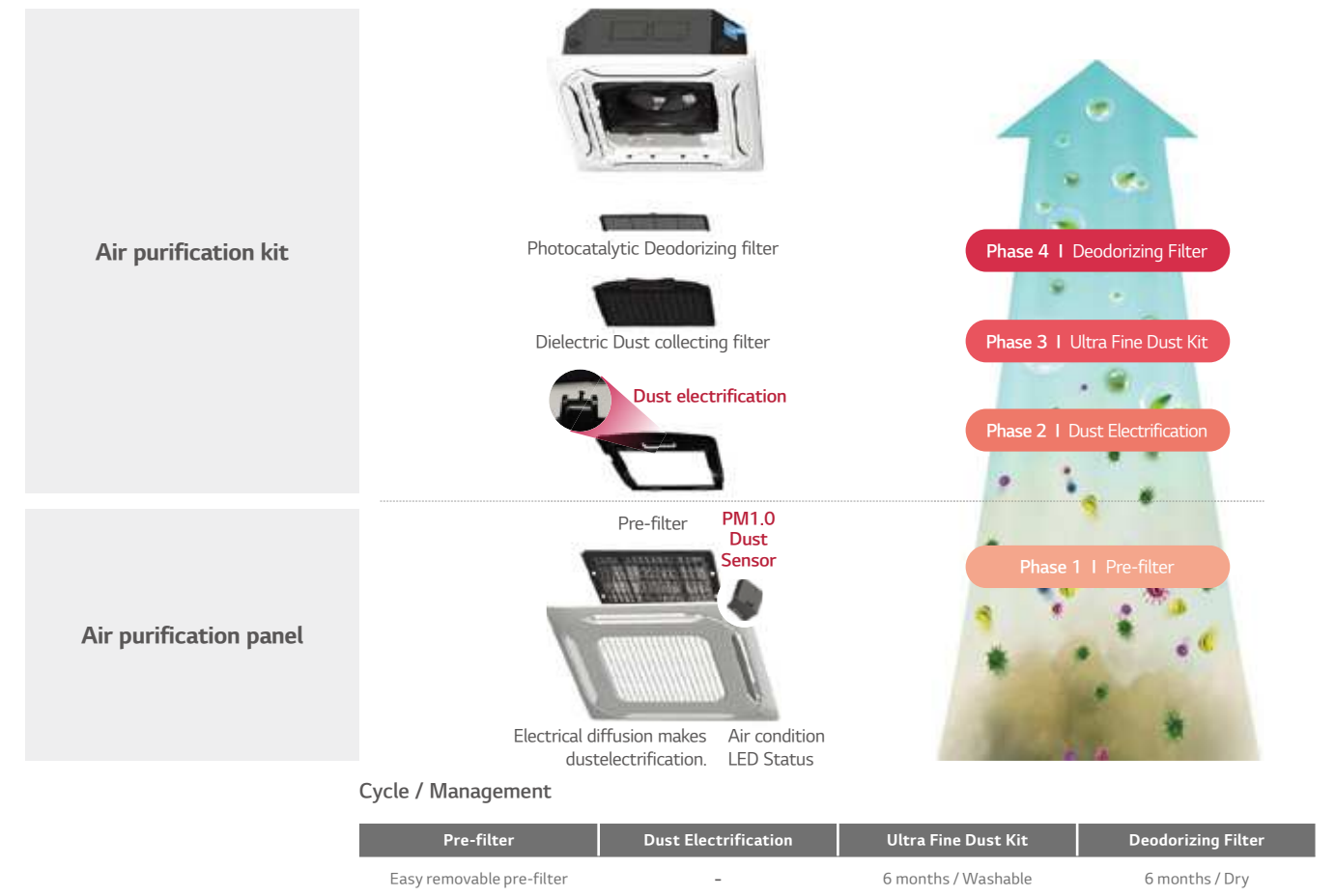

※ Available in case both Air Purification Kit (PTAFMP0) and Air purification panel (PT-AFGW0) are installed.

# SMART

## Various Display of Air purifying

Installed Wi-Fi leads unlimited boundary to control IDU and display air purifying status.

**① IDU LED**

Shows quality of Indoor air in real time

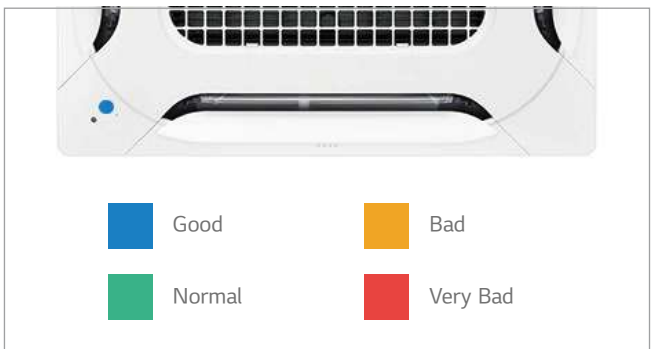

Good (Blue) | Bad (Orange)  
Normal (Green) | Very Bad (Red)

**② Remote controller**

Display Air status and Fine Dust Concentration



**③ Mobile**

Whenever & Wherever  
Check and Control Air status



## Pairing LG ThinQ

Anywhere! Anytime! Can connect to IDU with LG ThinQ

- ① Monitoring Air status Easy to check indoor air status
  - Ultra Fine / Extra Fine / Fine Dust
  - Day / Week /Month / Yearly
- ② Mobile Remote Control Remote control by using mobile phone
  - Control Mode / Temperature / Air flow etc.
- ③ Display Power Consumption Check power consumption of A/C
  - Check energy display
  - Set target energy consumption level



# CEILING MOUNTED CASSETTE



### H-INVERTER (R32)

UT09FH  
UT12FH  
UT18FH  
UT24FH  
UT30FH



UUA1.ULO    UUB1.U20    UUC1.U40



 LG participates in the ECP programme for EUROVENT AC program. Check ongoing validity of certification : [www.eurovent-certification.com](http://www.eurovent-certification.com)

COMBINATION				9	12	18	24	30
Capacity	Cooling	Min - Rated - Max	kW	1.6 / 2.5 / 4.0	1.6 / 3.4 / 4.8	2.0 / 5.0 / 6.0	2.7 / 6.8 / 8.3	3.2 / 8.0 / 9.5
	Heating	Min - Rated - Max	kW	1.7 / 3.2 / 4.5	1.7 / 4.1 / 5.8	2.3 / 5.8 / 7.0	3.2 / 7.9 / 9.9	3.6 / 9.0 / 10.7
Power Input (Set)	Cooling	Min - Rated - Max	kW	0.32 / 0.61 / 0.98	0.32 / 0.97 / 1.78	0.30 / 1.25 / 1.69	0.30 / 1.66 / 2.31	0.40 / 2.12 / 2.82
	Heating	Min - Rated - Max	kW	0.32 / 0.75 / 1.06	0.32 / 1.03 / 1.87	0.30 / 1.47 / 1.98	0.40 / 1.76 / 2.53	0.40 / 2.14 / 2.93
Running Current	Cooling	Rated	A	2.7	4.3	7.2	7.4	9.4
	Heating	Rated	A	3.3	4.6	7.7	7.8	9.5
EER / COP			kWh/kWh	4.10 / 4.30	3.50 / 4.00	4.00 / 3.95	4.10 / 4.48	3.77 / 4.20
SEER / SCOP			kWh/kWh	7.0 / 4.0	6.8 / 4.0	7.6 / 4.4	8.5 / 4.8	7.8 / 4.8
Pdesign	Cooling @ 35°C		kW	2.5	3.4	5.0	6.8	8
	Heating @ -10°C		kW	2.8	2.8	4.1	5.5	5.5
Seasonal Energy Label	Cooling / Heating			A++ / A+	A++ / A+	A++ / A+	A+++ / A++	A++ / A++
Annual Energy Consumption	Cooling / Heating		kWh	125 / 980	175 / 980	230 / 1,305	280 / 1,604	359 / 1,604
Dehumidification Rate			l/h	0.1	0.8	1.9	1.7	2.7
ODU Sound Pressure Level	Cooling / Heating	Rated	dB(A)	49 / 52	49 / 52	47 / 52	48 / 52	50 / 52
ODU Sound Power Level	Cooling	Rated	dB(A)	65	65	63	65	68
Piping Connections	Liquid		mm (inch)	Ø 6.35 (1/4)	Ø 6.35 (1/4)	Ø 6.35 (1/4)	Ø 9.52 (3/8)	Ø 9.52 (3/8)
	Gas		mm (inch)	Ø 9.52 (3/8)	Ø 9.52 (3/8)	Ø 12.7 (1/2)	Ø 15.88 (5/8)	Ø 15.88 (5/8)
	Connections Method		-	Flared	Flared	Flared	Flared	Flared
Operation Range (Outdoor)	Cooling	Min - Max	°C	-15 ~ 50	-15 ~ 50	-15 ~ 50	-20 ~ 50	-20 ~ 50
	Heating	Min - Max	°C	-20 ~ 18	-20 ~ 18	-20 ~ 18	-20 ~ 18	-20 ~ 18
INDOOR				<b>UT09FH.NQ0</b>	<b>UT12FH.NQ0</b>	<b>UT18FH.NB0</b>	<b>UT24FH.NA0</b>	<b>UT30FH.NA0</b>
Power Supply			Ø, V, Hz	1, 220-240, 50	1, 220-240, 50	1, 220-240, 50	1, 220-240, 50	1, 220-240, 50
Power Input (IDU)		H / M / L	W	30 / 26 / 22	30 / 26 / 22	33 / 26 / 22	43 / 35 / 28	43 / 35 / 28
Air Flow Rate		H / M / L	m³/min	11.0 / 10.0 / 9.3	11.0 / 10.0 / 9.3	17.0 / 15.5 / 14.0	23.8 / 21.4 / 19.0	23.8 / 21.4 / 19.0
Dimensions	Body	W x H x D	mm	570 x 256 x 570	570 x 256 x 570	840 x 204 x 840	840 x 288 x 840	840 x 288 x 840
Weight	Body		kg	13.9	13.9	21.1	25.3	25.3
Sound Pressure Level	Cooling	H / M / L	dB(A)	41 / 39 / 37	41 / 39 / 37	37 / 36 / 34	42 / 41 / 40	42 / 41 / 40
Sound Power Level	Cooling	Max.	dB(A)	54	54	52	56	56
Piping Connections	Drain	O.D. / I.D.	mm	Ø 32.0 / 25.0	Ø 32.0 / 25.0	Ø 32.0 / 25.0	Ø 32.0 / 25.0	Ø 32.0 / 25.0
Recommended Decoration Panel*	Model Name		-	PT-QAGW0	PT-QAGW0	PT-AFGW0	PT-AFGW0	PT-AFGW0
	Color		-	White	White	White	White	White
	Dimensions	Body	mm	620 x 34 x 620	620 x 34 x 620	950 x 35 x 950	950 x 35 x 950	950 x 35 x 950
	Weight	Body	kg	3.0	3.0	7.5	7.5	7.5
OUTDOOR				<b>UUA1.ULO</b>	<b>UUB1.U20</b>	<b>UUC1.U40</b>		
Power Supply			Ø, V, Hz	1, 220-240, 50	1, 220-240, 50	1, 220-240, 50		
Circuit Breaker		Min	A	15	20	25		
Power Supply Cable (included Earth)			No x mm²	3C x 2.5	3C x 2.5	3C x 2.5		
Dimensions	Net	W x H x D	mm	770 x 545 x 288	870 x 650 x 330	950 x 834 x 330		
Weight	Net		kg	33.3	44.5	57.7		
Compressor	Type		-	Twin Rotary	Twin Rotary	Twin Rotary		
	Type		-	R32	R32	R32		
	GWP (Global Warming Potential)		-	675	675	675		
	Refrigerant	Precharged Amount	kg	1.0	1.2	1.9		
Fan	t-CO <sub>2</sub> eq		-	0.675	0.81	1.283		
	Additional Charge (After 7.5m)		g/m	20	20	40		
	Air Flow Rate	Rated	m³/min x No.	28 x 1	50 x 1	58 x 1		
Total Piping Length		Min / Max	m	5 / 30	5 / 30	5 / 50		
Piping Elevation	IDU - ODU	Max	m	30	30	30		

\* Decoration panel can be selected as an optional accessory.

Note :

1. Due to our policy of innovation some specifications may be changed without notification.
2. Performances are based on the following conditions (It is accordance with EN14511)
  - Cooling : Indoor Ambient Temp. 27°CDB / 19°CWB, Outdoor Ambient Temp. 35°CDB / 24°CWB
  - Heating : Indoor Ambient Temp. 20°CDB / 15°CWB, Outdoor Ambient Temp. 7°CDB / 6°CWB
  - Interconnected Pipe is standard length and difference of Elevation (Outdoor - Indoor Unit) is 0m.
3. Sound Level Values are measured at Noise Measuring chamber accordance with standard. Therefore, these values depend on the ambient conditions and values are normally higher in actual operation
4. This product contains fluorinated greenhouse gases (R32)







# CASSETTE PANEL



## Model Name

PT-AAGWO  
PT-AEGWO  
PT-AFGWO  
PT-QAGWO

## Key Features

Model	Function					
	Dual Vane	Wi-Fi	Floor Temperature Sensor	Air Purification	Elevating Grille	Occupancy Sensor
PT-AAGWO	0	Optional	X	X	X	Optional
PT-AEGWO	0	Optional	X	X	0	Optional
PT-AFGWO	0	Optional	0	Optional	X	Optional

## Specification

Model	Suction Type	Color (RAL)	Gloss	Weight (kg)	Dimension (mm)		
					W	H	D
PT-AAGWO	Grid	White (RAL 9003)	-	7.1	950	35	950
PT-AEGWO	Grid	White (RAL 9003)	-	8.5	950	35	950
PT-AFGWO	Grid	White (RAL 9003)	-	7.5	950	35	950
PT-QAGWO	Grid	White (RAL 9003)	-	3.0	620	34	620

## Air Purification Kit

Model	Image	Model name	Dielectric Dust collecting filter	Photocatalytic Deodorizing filter	HVPS	Ionizer
Air cleaning kit		PTAFMPO	0	0	0	0

# CASSETTE COVER

Cover in case of exposed cassette installation.

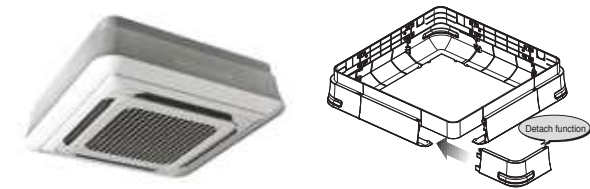

## Key Features

- Specially designed for indoor unit
- Covers the side area of cassette
- Gives elegant looks
- Light weight

## Specification

Model	Front Panel		Weight (kg)		Dimensions (mm)		
			NET	Gross	W	H	D
PTDCQ	PT-UQC	TR	5.0	7.2	907	907	268
		TQ	5.0	7.2	907	907	310

\* PTDCQ suitable for Dual Vane 4 Way CST (840 x 840) will be available later

## Model Name

PTDCQ / PTDCQ\*

## Applied Products

4 Way Cassette (for chassis TQ, TR)

## Included Parts

- Cover A, Cover B
- Cover C, Cover D
- Screws
- Installation Manual

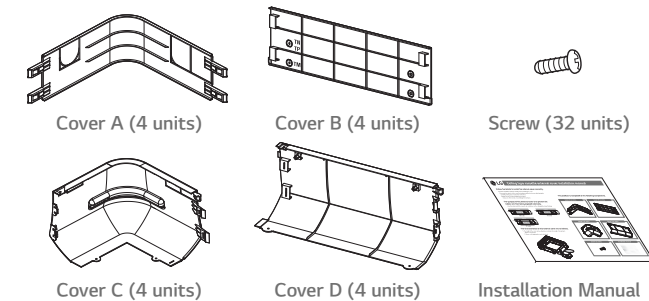

# CEILING CONCEALED DUCT



# CEILING CONCEALED DUCT

## External Static Pressure (ESP) Control

User has easy access to air volume selection via remote controller using the ESP control function. The BLDC motor can control fan speed and air volume. No additional accessories are necessary to control air flow.

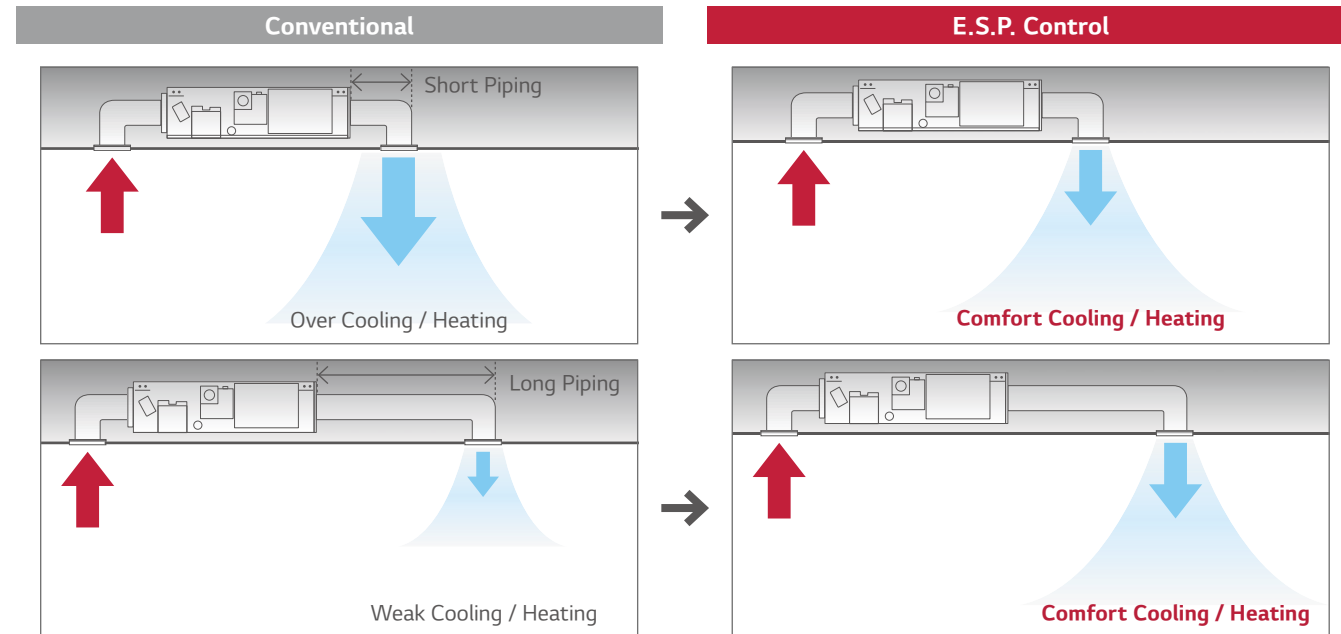

## High Head Drain Pump

High head drain pump automatically drains water up to a height of 700mm of drain-head height. It provides the perfect solution for draining of water. (Standard Inverter : Accessory (ABDPG) / Low-Static Duct : Included)

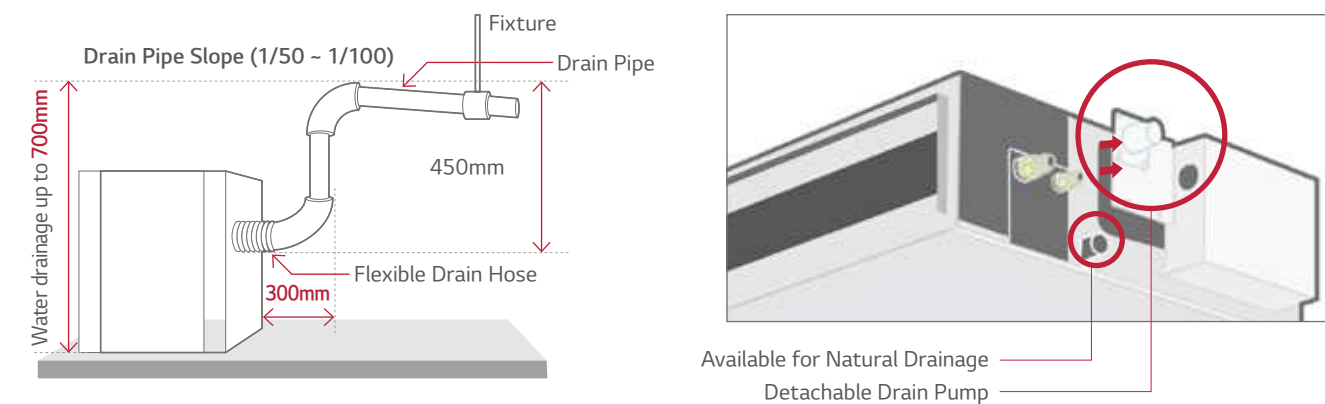

# CEILING CONCEALED DUCT

## Two Thermistors Control

The indoor temperature can be checked using the thermistors in the remote controller as well as from the indoor unit. There may be a significant difference between ceiling and floor air temperature. Two thermistors can optimise indoor air temperature for a more comfortable environment.

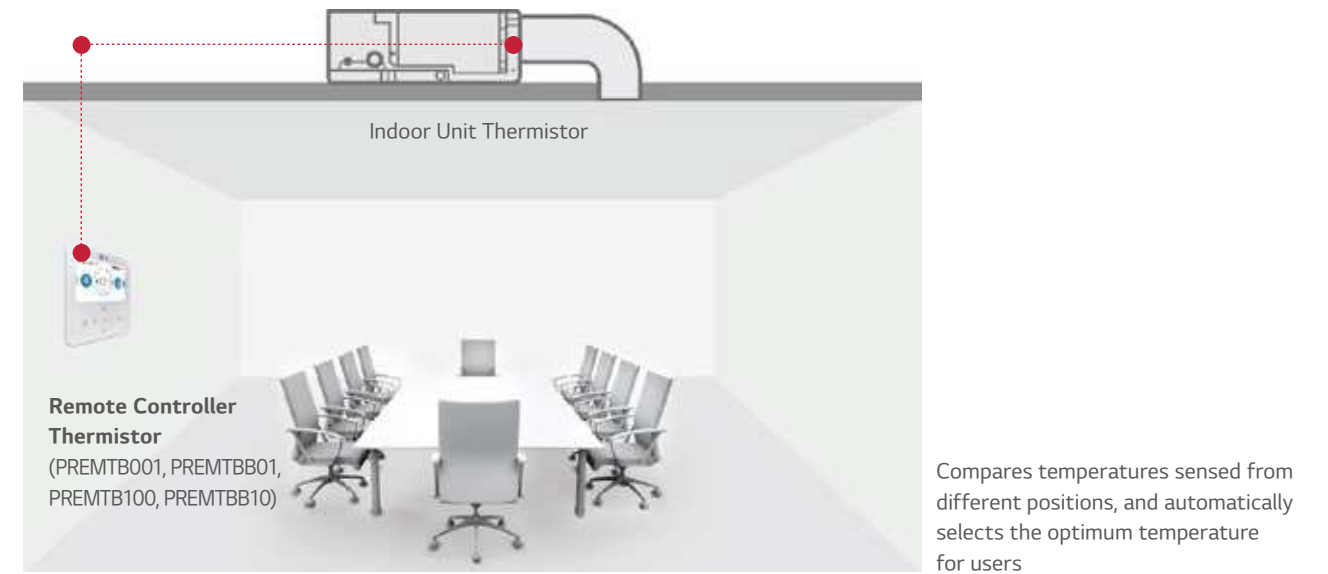

## Operation for Multiple Rooms

Using a spiral duct (Embedded or flexible type) and stream chamber, it is possible to operate cooling / heating for several rooms simultaneously. Also, zone control is available with zone controller accessory (ABZCA)

### Zone control features

- Controls different zones (up to 4 zones) by external thermostat (AC 24V)
- Maintain proper air volume of each zone
- Auto variation of dampers
- Auto control of fan speed and On / Off operation

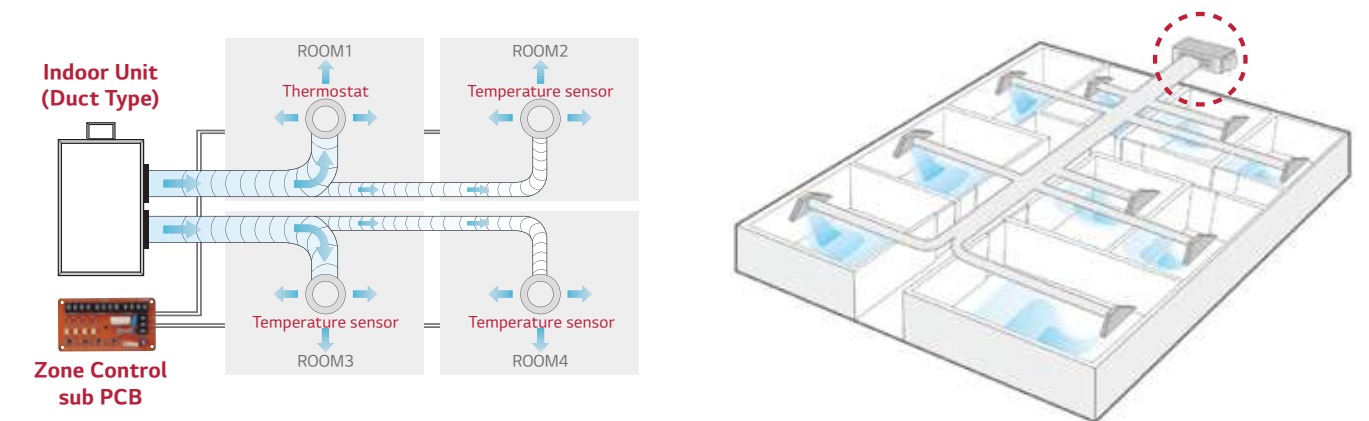



# CEILING CONCEALED DUCT

## Minimized Height and Depth

New Low Static ducts provide ideal solution for installation in limited space

### Low Static Duct

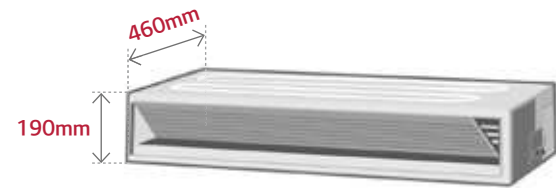

### Depth

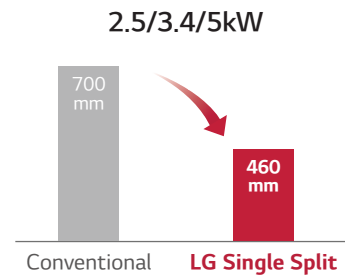

\*CL09FN50, CL12FN50, CL18FN60, UL12FH.N50 only

## Wide Operation Range

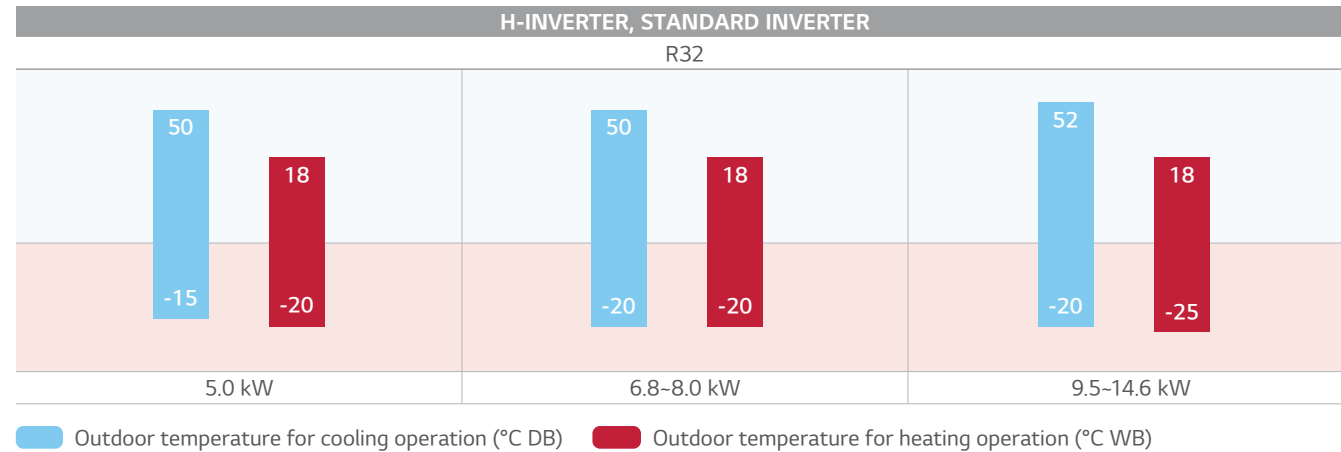

## Easy Service & Maintenance

Users are not required to disassemble the whole panel for maintenance; since panel is divided into 2 components; one for heat exchanger and the other for fan/motor. The user can easily detach and re-attach the filter in the available limited space.

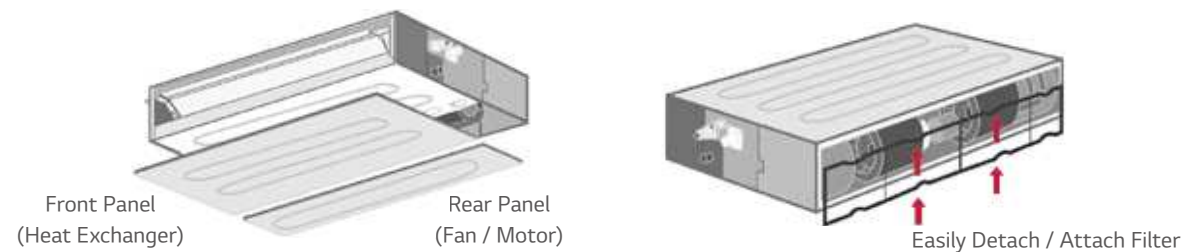

# CEILING CONCEALED DUCT (LOW STATIC PRESSURE)

## Quiet Operation

The noise level of low static ducts have been reduced, even though ESP has been increased.

	CL09F N50	CL12F N50	CL18F N60	CL24F N30
Sound Pressure (High / Medium / Low) dB (A)	35/30/27	35/30/27	34/31/29	39 / 35 / 32

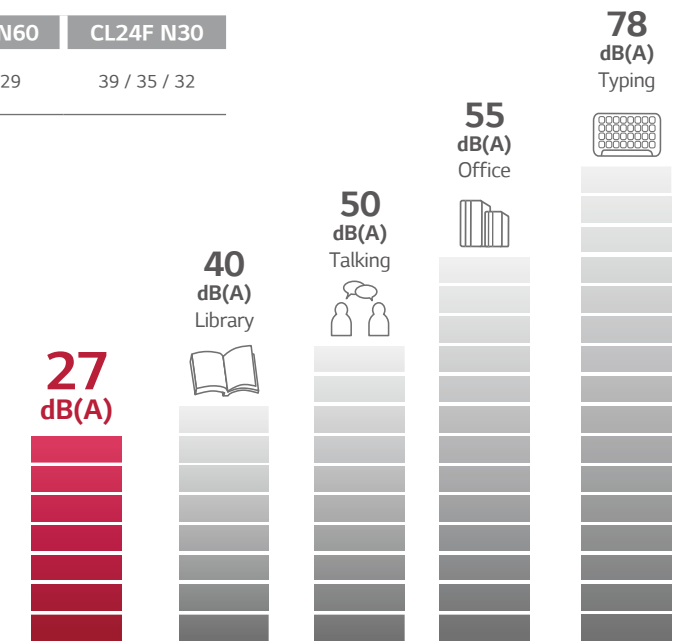

## Flexible Installation

Standard Inverter low static duct allows the air intake at the rear or bottom under installation condition.

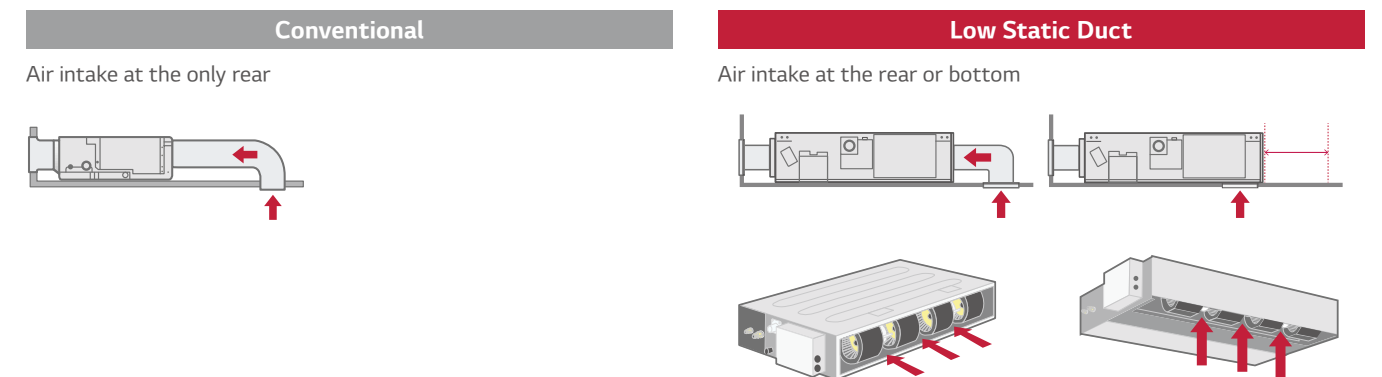

# CEILING CONCEALED DUCT



## H-INVERTER (R32)

LOW STATIC PRESSURE  
- UL12FH / UL18FH



LG participates in the ECP programme for EUROVENT AC program.  
Check ongoing validity of certification  
: www.eurovent-certification.com

UUA1.ULO UUB1.U20



COMBINATION				12	18
Capacity	Cooling	Min - Rated - Max	kW	1.5 / 3.4 / 4.7	2.0 / 5.0 / 6.0
	Heating	Min - Rated - Max	kW	1.8 / 4.0 / 4.9	2.3 / 5.8 / 7.0
Power Input (Set)	Cooling	Min - Rated - Max	kW	0.33 / 1.06 / 1.84	0.30 / 1.39 / 1.88
	Heating	Min - Rated - Max	kW	0.33 / 1.08 / 1.63	0.30 / 1.57 / 2.12
Running Current	Cooling	Rated	A	4.7	7.6
	Heating	Rated	A	4.8	8.1
EER / COP			kWh/kWh	3.20 / 3.70	3.60 / 3.70
SEER / SCOP			kWh/kWh	6.1 / 4.0	6.5 / 4.1
Pdesign	Cooling @ 35°C		kW	3.4	5
	Heating @ -10°C		kW	2.9	4.1
Seasonal Energy Label	Cooling / Heating			A++ / A+	A++ / A+
Annual Energy Consumption	Cooling / Heating		kWh	195 / 1,015	269 / 1,400
Dehumidification Rate			l/h	0.8	2.6
ODU Sound Pressure Level	Cooling / Heating	Rated	dB(A)	49 / 52	47 / 52
	Cooling	Rated	dB(A)	65	63
Piping Connections	Liquid		mm (inch)	φ 6.35 (1/4)	φ 6.35 (1/4)
	Gas		mm (inch)	φ 9.52 (3/8)	φ 12.7 (1/2)
	Connections Method			FLARED	Flared
Operation Range (Outdoor)	Cooling	Min - Max	°C	-15 - 50	-15 - 50
	Heating	Min - Max	°C	-20 - 18	-20 - 18

INDOOR				UL12FH.N50	UL18FH.N30
Power Supply			∅, V, Hz	1, 220-240, 50	1, 220-240, 50
Power Input (IDU)		H / M / L	W	21 / 15 / 13	140 / 125 / 100
Air Flow Rate		H / M / L	m³/min	11.5 / 9.5 / 8	18.5 / 15 / 11
Dimensions	Body	W x H x D	mm	900 x 190 x 460	1,100 x 190 x 700
Weight	Body		kg	18	26.0
Sound Pressure Level	Cooling	H / M / L	dB(A)	35 / 30 / 27	38 / 34 / 31
Sound Power Level	Cooling	Max.	dB(A)	55	56
Piping Connections	Drain	O.D. / I.D.	mm	φ 32.0 / 26.0	φ 32.0 / 26.0

OUTDOOR				UUA1.ULO	UUB1.U20
Power Supply			∅, V, Hz	1, 220-240, 50	1, 220-240, 50
Circuit Breaker		Min	A	15	20
Power Supply Cable (included Earth)			No x mm²	3C x 2.5	3C x 2.5
Dimensions	Net	W x H x D	mm	770 x 545 x 288	870 x 650 x 330
Weight	Net		kg	33.3	44.5
Compressor	Type			Twin Rotary	Twin Rotary
				R32	R32
Refrigerant	GWP (Global Warming Potential)			675	675
	Precharged Amount		kg	1.0	1.2
	t-CO <sub>2</sub> eq.			0.675	0.81
	Additional Charge (After 7.5m)		g/m	20	20
Fan	Air Flow Rate	Rated	m³/min x No.	28 x 1	50 x 1
Total Piping Length		Min / Max	m	5 / 30	5 / 30
Piping Elevation	IDU - ODU	Max	m	30	30

# CEILING CONCEALED DUCT



## H-INVERTER (R32)

MID STATIC PRESSURE  
- UM12FH / UM18FH / UM24FH / UM30FH



LG participates in the ECP programme for EUROVENT AC program.  
Check ongoing validity of certification  
: www.eurovent-certification.com

UUA1.ULO UUB1.U20 UUC1.U40



COMBINATION				12	18	24	30
Capacity	Cooling	Min - Rated - Max	kW	1.6 / 3.5 / 5.1	2.0 / 5.0 / 6.0	2.7 / 6.8 / 8.3	3.1 / 7.8 / 9.3
	Heating	Min - Rated - Max	kW	1.6 / 4.0 / 5.8	2.3 / 5.8 / 7.0	3.0 / 7.5 / 9.4	3.6 / 9.0 / 10.7
Power Input (Set)	Cooling	Min - Rated - Max	kW	0.32 / 1.03 / 1.93	0.30 / 1.26 / 1.70	0.40 / 1.84 / 2.56	0.50 / 2.25 / 2.99
	Heating	Min - Rated - Max	kW	0.32 / 0.98 / 1.85	0.30 / 1.49 / 2.01	0.40 / 1.75 / 2.52	0.50 / 2.27 / 3.11
Running Current	Cooling	Rated	A	4.6	7.3	8.2	10.0
	Heating	Rated	A	4.3	7.8	7.8	10.1
EER / COP			kWh/kWh	3.40 / 4.10	3.96 / 3.89	3.70 / 4.28	3.51 / 3.97
SEER / SCOP			kWh/kWh	6.1 / 3.9	6.6 / 4.2	6.8 / 4.3	6.6 / 4.3
Pdesign	Cooling @ 35°C		kW	3.5	5	6.8	7.8
	Heating @ -10°C		kW	2.8	4.4	5.4	5.4
Seasonal Energy Label	Cooling / Heating			A++ / A	A++ / A+	A++ / A+	A++ / A+
Annual Energy Consumption	Cooling / Heating		kWh	201 / 1,005	265 / 1,467	350 / 1,758	419 / 1,758
Dehumidification Rate			l/h	0.4	1.3	1.2	2.2
ODU Sound Pressure Level	Cooling / Heating	Rated	dB(A)	49 / 52	47 / 52	48 / 52	50 / 52
	Cooling	Rated	dB(A)	65	63	65	68
Piping Connections	Liquid		mm (inch)	φ 6.35 (1/4)	φ 6.35 (1/4)	φ 9.52 (3/8)	φ 9.52 (3/8)
	Gas		mm (inch)	φ 9.52 (3/8)	φ 12.7 (1/2)	φ 15.88 (5/8)	φ 15.88 (5/8)
	Connections Method			Flared	Flared	Flared	Flared
Operation Range (Outdoor)	Cooling	Min - Max	°C	-15 - 50	-15 - 50	-20 - 50	-20 - 50
	Heating	Min - Max	°C	-20 - 18	-20 - 18	-20 - 18	-20 - 18

INDOOR				UM12FH.N10	UM18FH.N10	UM24FH.N20	UM30FH.N20
Power Supply			∅, V, Hz	1, 220-240, 50	1, 220-240, 50	1, 220-240, 50	1, 220-240, 50
Power Input (IDU)		H / M / L	W	150 / 130 / 110	134 / 101 / 80	134 / 101 / 80	134 / 101 / 80
Air Flow Rate		H / M / L	m³/min	16.5 / 14.5 / 13	17.5 / 16 / 14	28 / 24 / 21	28 / 24 / 21
Dimensions	Body	W x H x D	mm	900 x 270 x 700	900 x 270 x 700	1,250 x 270 x 700	1,250 x 270 x 700
Weight	Body		kg	25.4	27.0	39.3	39.3
Sound Pressure Level	Cooling	H / M / L	dB(A)	34 / 32 / 30	35 / 34 / 32	34 / 33 / 32	34 / 33 / 32
Sound Power Level	Cooling	Max.	dB(A)	56	60	59	59
Piping Connections	Drain (Natural Drainage)	O.D. / I.D.	mm	φ 25.4 / 19.4	φ 25.4 / 19.4	φ 25.4 / 19.4	φ 25.4 / 19.4
	Drain (Using Drain Pump)	O.D. / I.D.	mm	φ 32.0 / 26.0	φ 32.0 / 26.0	φ 32.0 / 26.0	φ 32.0 / 26.0

OUTDOOR				UUA1.ULO	UUB1.U20	UUC1.U40
Power Supply			∅, V, Hz	1, 220-240, 50	1, 220-240, 50	1, 220-240, 50
Circuit Breaker		Min	A	15	20	25
Power Supply Cable (included Earth)			No x mm²	3C x 2.5	3C x 2.5	3C x 2.5
Dimensions	Net	W x H x D	mm	770 x 545 x 288	870 x 650 x 330	950 x 834 x 330
Weight	Net		kg	33.3	44.5	57.7
Compressor	Type			Twin Rotary	Twin Rotary	Twin Rotary
				R32	R32	R32
Refrigerant	GWP (Global Warming Potential)			675	675	675
	Precharged Amount		kg	1.0	1.2	1.9
	t-CO <sub>2</sub> eq.			0.675	0.81	1.283
	Additional Charge (After 7.5m)		g/m	20	20	40
Fan	Air Flow Rate	Rated	m³/min x No.	28 x 1	50 x 1	58 x 1
Total Piping Length		Min / Max	m	5 / 30	5 / 30	5 / 50
Piping Elevation	IDU - ODU	Max	m	30	30	30

# CEILING CONCEALED DUCT



## H-INVERTER (R32)

MID STATIC PRESSURE  
- UM36FH / UM42FH / UM48FH

UUD1.U30



LG participates in the ECP programme for EUROVENT AC program.  
Check ongoing validity of certification  
: www.eurovent-certification.com

COMBINATION				36	42	48
Capacity	Cooling	Min - Rated - Max	kW	3.8 / 9.5 / 12.8	4.8 / 12.0 / 14.4	5.4 / 13.4 / 16.1
	Heating	Min - Rated - Max	kW	4.3 / 10.8 / 13.7	5.4 / 13.5 / 16.2	6.2 / 15.5 / 17.8
Power Input (Set)	Cooling	Min - Rated - Max	kW	0.50 / 2.26 / 3.39	0.70 / 3.38 / 4.56	0.80 / 4.12 / 5.56
	Heating	Min - Rated - Max	kW	0.50 / 2.57 / 3.60	0.70 / 3.51 / 4.56	0.80 / 4.19 / 5.24
Running Current	Cooling	Rated	A	10.0	14.9	18.1
	Heating	Rated	A	11.3	15.3	18.4
EER / COP			kWh/kWh	4.20 / 4.20	3.55 / 3.85	3.25 / 3.70
SEER / SCOP			kWh/kWh	6.4 / 4.2	6.2 / 4.1	6.1 / 4.1
Pdesign	Cooling @ 35°C		kW	9.5	12	13.4
	Heating @ -10°C		kW	9.5	9.5	9.5
Seasonal Energy Label	Cooling / Heating			A++ / A+	A++ / A+	-
Annual Energy Consumption	Cooling / Heating		kWh	520 / 3,167	677 / 3,244	1,318 / 3,244
Dehumidification Rate			l/h	2.0	4.2	4.8
ODU Sound Pressure Level	Cooling / Heating	Rated	dB(A)	50 / 50	51 / 52	52 / 53
ODU Sound Power Level	Cooling	Rated	dB(A)	66	69	69
Piping Connections	Liquid		mm (inch)	φ 9.52 (3/8)	φ 9.52 (3/8)	φ 9.52 (3/8)
	Gas		mm (inch)	φ 15.88 (5/8)	φ 15.88 (5/8)	φ 15.88 (5/8)
	Connections Method			Flared	Flared	Flared
Operation Range (Outdoor)	Cooling	Min - Max	°C	-20 - 52	-20 - 52	-20 - 52
	Heating	Min - Max	°C	-25 - 18	-25 - 18	-25 - 18
<b>INDOOR</b>				<b>UM36FH.N30</b>	<b>UM42FH.N30</b>	<b>UM48FH.N30</b>
Power Supply			Ø, V, Hz	1, 220-240, 50	1, 220-240, 50	1, 220-240, 50
Power Input (IDU)		H / M / L	W	242 / 159 / 124	242 / 159 / 124	242 / 159 / 124
Air Flow Rate		H / M / L	m³/min	40 / 34 / 28	40 / 34 / 28	40 / 34 / 28
Dimensions	Body	W x H x D	mm	1,250 x 360 x 700	1,250 x 360 x 700	1,250 x 360 x 700
Weight	Body		kg	44.3	44.3	44.3
Sound Pressure Level	Cooling	H / M / L	dB(A)	39 / 38 / 36	39 / 38 / 36	39 / 38 / 36
Sound Power Level	Cooling	Max.	dB(A)	65	65	65
Piping Connections	Drain (Natural Drainage)	O.D. / I.D.	mm	φ 25.4 / 19.4	φ 25.4 / 19.4	φ 25.4 / 19.4
	Drain (Using Drain Pump)	O.D. / I.D.	mm	φ 32.0 / 26.0	φ 32.0 / 26.0	φ 32.0 / 26.0
<b>OUTDOOR</b>				<b>UUD1.U30</b>		
Power Supply			Ø, V, Hz	1, 220-240, 50		
Circuit Breaker		Min	A	40		
Power Supply Cable (included Earth)			No x mm²	3C x 6.0		
Dimensions	Net	W x H x D	mm	950 x 1,380 x 330		
Weight	Net		kg	85.0		
Compressor	Type			Inverter Scroll		
	Type			R32		
Refrigerant	GWP (Global Warming Potential)			675		
	Precharged Amount		kg	3.0		
	t-CO <sub>2</sub> eq.			2.025		
	Additional Charge (After 7.5m)		g/m	40		
Fan	Air Flow Rate	Rated	m³/min x No.	55 x 2		
Total Piping Length		Min / Max	m	5 / 85		
Piping Elevation	IDU - ODU	Max	m	30		

# CEILING CONCEALED DUCT



## H-INVERTER (R32)

MID STATIC PRESSURE  
- UM36FH / UM42FH / UM48FH

UUD3.U30



LG participates in the ECP programme for EUROVENT AC program.  
Check ongoing validity of certification  
: www.eurovent-certification.com



COMBINATION				36	42	48
Capacity	Cooling	Min - Rated - Max	kW	3.8 - 9.5 - 12.8	4.8 - 12.0 - 14.4	5.4 - 13.4 - 16.1
	Heating	Min - Rated - Max	kW	4.3 - 10.8 - 13.7	5.4 - 13.5 - 16.2	6.2 - 15.5 - 17.8
Power Input (Set)	Cooling	Min - Rated - Max	kW	0.50 - 2.26 - 3.39	0.70 - 3.38 - 4.56	0.80 - 4.12 - 5.56
	Heating	Min - Rated - Max	kW	0.50 - 2.57 - 3.60	0.70 - 3.51 - 4.56	0.80 - 4.19 - 5.24
Running Current	Cooling	Rated	A	3.8	5.3	6.5
	Heating	Rated	A	4.1	5.5	6.5
EER / COP			kWh/kWh	4.20 / 4.20	3.55 / 3.85	3.25 / 3.70
SEER / SCOP			kWh/kWh	6.4 / 4.2	6.2 / 4.1	6.1 / 4.1
Pdesign	Cooling @ 35°C		kW	9.5	12	13.4
	Heating @ -10°C		kW	9.5	9.5	9.5
Seasonal Energy Label	Cooling / Heating			A++ / A+	A++ / A+	-
Annual Energy Consumption	Cooling / Heating		kWh	520 / 3,167	677 / 3,244	1,318 / 3,244
Dehumidification Rate			l/h	2.0	4.2	4.8
ODU Sound Pressure Level	Cooling / Heating	Rated	dB(A)	50 / 50	51 / 52	52 / 53
ODU Sound Power Level	Cooling	Rated	dB(A)	66	69	69
Piping Connections	Liquid		mm (inch)	φ 9.52 (3/8)	φ 9.52 (3/8)	φ 9.52 (3/8)
	Gas		mm (inch)	φ 15.88 (5/8)	φ 15.88 (5/8)	φ 15.88 (5/8)
	Connections Method			Flared	Flared	Flared
Operation Range (Outdoor)	Cooling	Min - Max	°C	-20 - 52	-20 - 52	-20 - 52
	Heating	Min - Max	°C	-25 - 18	-25 - 18	-25 - 18
<b>INDOOR</b>				<b>UM36FH.N30</b>	<b>UM42FH.N30</b>	<b>UM48FH.N30</b>
Power Supply			Ø, V, Hz	1, 220-240, 50	1, 220-240, 50	1, 220-240, 50
Power Input (IDU)		H / M / L	W	242 / 159 / 124	242 / 159 / 124	242 / 159 / 124
Air Flow Rate		H / M / L	m³/min	40 / 34 / 28	40 / 34 / 28	40 / 34 / 28
Dimensions	Body	W x H x D	mm	1,250 x 360 x 700	1,250 x 360 x 700	1,250 x 360 x 700
Weight	Body		kg	44.3	44.3	44.3
Sound Pressure Level	Cooling	H / M / L	dB(A)	39 / 38 / 36	39 / 38 / 36	39 / 38 / 36
Sound Power Level	Cooling	Max.	dB(A)	65	65	65
Piping Connections	Drain (Natural Drainage)	O.D. / I.D.	mm	φ 25.4 / 19.4	φ 25.4 / 19.4	φ 25.4 / 19.4
	Drain (Using Drain Pump)	O.D. / I.D.	mm	φ 32.0 / 26.0	φ 32.0 / 26.0	φ 32.0 / 26.0
<b>OUTDOOR</b>				<b>UUD3.U30</b>		
Power Supply			Ø, V, Hz	3, 380-415, 50		
Circuit Breaker		Min	A	20		
Power Supply Cable (included Earth)			No x mm²	5C x 2.5		
Dimensions	Net	W x H x D	mm	950 x 1,380 x 330		
Weight	Net		kg	85.0		
Compressor	Type			Inverter Scroll		
	Type			R32		
Refrigerant	GWP (Global Warming Potential)			675		
	Precharged Amount		kg	3.0		
	t-CO <sub>2</sub> eq.			2.025		
	Additional Charge (After 7.5m)		g/m	40		
Fan	Air Flow Rate	Rated	m³/min x No.	55 x 2		
Total Piping Length		Min / Max	m	5 / 85		
Piping Elevation	IDU - ODU	Max	m	30		

# CEILING CONCEALED DUCT



## STANDARD INVERTER (R32)

LOW STATIC PRESSURE  
- CL09F / CL12F / CL18F / CL24F



LG participates in the ECP programme for EUROVENT AC program.  
Check ongoing validity of certification  
: www.eurovent-certification.com

UUA1.U10

UUB1.U20

UUC1.U40



COMBINATION				09	12	18	24
Capacity	Cooling	Min - Rated - Max	kW	1.5 / 2.5 / 3.2	1.5 / 3.4 / 4.7	2.0 / 5.0 / 5.8	2.7 / 6.8 / 7.8
	Heating	Min - Rated - Max	kW	1.8 / 3.2 / 4.0	1.8 / 4.0 / 4.9	2.3 / 5.8 / 6.7	3.0 / 7.5 / 9.0
Power Input (Set)	Cooling	Min - Rated - Max	kW	0.30 / 0.67 / 0.93	0.33 / 1.06 / 1.84	0.3 / 1.35 / 1.89	0.4 / 2.03 / 2.84
	Heating	Min - Rated - Max	kW	0.38 / 0.75 / 1.63	0.33 / 1.08 / 1.63	0.4 / 1.77 / 2.48	0.4 / 2.13 / 3.30
Running Current	Cooling	Rated	A	3.0	4.7	7.5	9.0
	Heating	Rated	A	3.3	4.8	8.3	9.4
EER / COP			kWh/kWh	3.80 / 4.30	3.20 / 3.70	3.71 / 3.28	3.35 / 3.52
SEER / SCOP			kWh/kWh	6.1 / 4.0	5.6 / 3.8	6.1 / 3.9	6.2 / 3.9
Pdesign	Cooling @ 35°C		kW	2.5	3.4	5	6.8
	Heating @ -10°C		kW	2.9	2.9	4.1	5.4
Seasonal Energy Label	Cooling / Heating		-	A++ / A+	A+ / A	A++ / A	A++ / A
Annual Energy Consumption	Cooling / Heating		kWh	143 / 1,015	213 / 1,068	287 / 1,472	384 / 1,938
Dehumidification Rate			l/h	0.2	0.8	1.6	2.5
ODU Sound Pressure Level	Cooling / Heating	Rated	dB(A)	49 / 52	49 / 52	47 / 52	48 / 52
ODU Sound Power Level	Cooling	Rated	dB(A)	65	65	63	65
Piping Connections	Liquid		mm (inch)	Φ 6.35 (1/4)	Φ 6.35 (1/4)	Φ 6.35 (1/4)	Φ 9.52 (3/8)
	Gas		mm (inch)	Φ 9.52 (3/8)	Φ 9.52 (3/8)	Φ 12.7 (1/2)	Φ 15.88 (5/8)
	Connections Method		-	Flared	Flared	Flared	Flared
Operation Range (Outdoor)	Cooling	Min - Max	°C	-15 - 50	-15 - 50	-15 - 50	-20 - 50
	Heating	Min - Max	°C	-20 - 18	-20 - 18	-20 - 18	-20 - 18

INDOOR				CL09F.N50	CL12F.N50	CL18F.N60	CL24F.N30
Power Supply			Ø, V, Hz	1, 220-240, 50	1, 220-240, 50	1, 220-240, 50	1, 220-240, 50
Power Input (IDU)		H / M / L	W	21 / 15 / 13	21 / 15 / 13	100 / 90 / 80	150 / 130 / 110
Air Flow Rate		H / M / L	m³/min	11.5 / 9.5 / 8	11.5 / 9.5 / 8	15 / 12 / 10	20 / 16 / 12
Dimensions	Body	W x H x D	mm	900 x 190 x 460	900 x 190 x 460	1,100 x 190 x 460	1,100 x 190 x 700
Weight	Body		kg	18.0	18.0	20.9	26.0
Sound Pressure Level	Cooling	H / M / L	dB(A)	35 / 30 / 27	35 / 30 / 27	34 / 31 / 29	39 / 35 / 32
Sound Power Level	Cooling	Max.	dB(A)	55	55	56	58
Piping Connections	Drain	O.D. / I.D.	mm	Φ 32.0 / 26.0	Φ 32.0 / 26.0	Φ 32.0 / 26.0	Φ 32.0 / 26.0

OUTDOOR				UUA1.U10	UUB1.U20	UUC1.U40
Power Supply			Ø, V, Hz	1, 220-240, 50	1, 220-240, 50	1, 220-240, 50
Circuit Breaker		Min	A	15	20	25
Power Supply Cable (included Earth)			No x mm²	3C x 2.5	3C x 2.5	3C x 2.5
Dimensions	Net	W x H x D	mm	770 x 545 x 288	870 x 650 x 330	950 x 834 x 330
Weight	Net		kg	33.3	44.5	57.7
Compressor	Type		-	Twin Rotary	Twin Rotary	Twin Rotary
Refrigerant	Type		-	R32	R32	R32
	GWP (Global Warming Potential)		-	675	675	675
	Precharged Amount		kg	1.0	1.2	1.9
	t-CO <sub>2</sub> eq.		-	0.675	0.81	1.283
	Additional Charge (After 7.5m)		g/m	20	20	40
Fan	Air Flow Rate	Rated	m³/min x No.	28 x 1	50 x 1	58 x 1
Total Piping Length		Min / Max	m	5 / 30	5 / 30	5 / 50
Piping Elevation	IDU - ODU	Max	m	30	30	30

# CEILING CONCEALED DUCT



## STANDARD INVERTER (R32)

MID STATIC PRESSURE  
- CM18F / CM24F / UM30F



LG participates in the ECP programme for EUROVENT AC program.  
Check ongoing validity of certification  
: www.eurovent-certification.com

UUB1.U20

UUC1.U40



COMBINATION				18	24	30
Capacity	Cooling	Min - Rated - Max	kW	2.0 / 5.0 / 5.8	2.7 / 6.8 / 8.0	3.1 / 7.8 / 9.0
	Heating	Min - Rated - Max	kW	2.3 / 5.8 / 6.7	3.0 / 7.5 / 9.0	3.6 / 9.0 / 10.1
Power Input (Set)	Cooling	Min - Rated - Max	kW	0.30 / 1.33 / 1.86	0.40 / 1.95 / 2.69	0.40 / 2.23 / 3.03
	Heating	Min - Rated - Max	kW	0.40 / 1.76 / 2.46	0.50 / 2.27 / 3.29	0.50 / 2.64 / 3.33
Running Current	Cooling	Rated	A	7.4	8.7	9.9
	Heating	Rated	A	8.3	10.1	11.7
EER / COP			kWh/kWh	3.75 / 3.30	3.49 / 3.31	3.50 / 3.41
SEER / SCOP			kWh/kWh	6.4 / 4.1	6.6 / 3.9	6.1 / 4.0
Pdesign	Cooling @ 35°C		kW	5	6.8	7.8
	Heating @ -10°C		kW	4.1	5.4	5.4
Seasonal Energy Label	Cooling / Heating		-	A++ / A+	A++ / A	A++ / A+
Annual Energy Consumption	Cooling / Heating		kWh	273 / 1,400	361 / 1,938	448 / 1,890
Dehumidification Rate			l/h	1.2	2.6	2.4
ODU Sound Pressure Level	Cooling / Heating	Rated	dB(A)	47 / 52	48 / 52	50 / 52
ODU Sound Power Level	Cooling	Rated	dB(A)	63	65	68
Piping Connections	Liquid		mm (inch)	Φ 6.35 (1/4)	Φ 9.52 (3/8)	Φ 9.52 (3/8)
	Gas		mm (inch)	Φ 12.7 (1/2)	Φ 15.88 (5/8)	Φ 15.88 (5/8)
	Connections Method		-	Flared	Flared	Flared
Operation Range (Outdoor)	Cooling	Min - Max	°C	-15 - 50	-20 - 50	-20 - 50
	Heating	Min - Max	°C	-20 - 18	-20 - 18	-20 - 18

INDOOR				CM18F.N10	CM24F.N10	UM30F.N10
Power Supply			Ø, V, Hz	1, 220-240, 50	1, 220-240, 50	1, 220-240, 50
Power Input (IDU)		H / M / L	W	150 / 130 / 110	180 / 150 / 130	220 / 200 / 180
Air Flow Rate		H / M / L	m³/min	16.5 / 14.5 / 13	18 / 16.5 / 14.5	22 / 20 / 18
Dimensions	Body	W x H x D	mm	900 x 270 x 700	900 x 270 x 700	900 x 270 x 700
Weight	Body		kg	24.6	24.6	26.2
Sound Pressure Level	Cooling	H / M / L	dB(A)	34 / 32 / 30	35 / 34 / 32	37 / 35 / 34
Sound Power Level	Cooling	Max.	dB(A)	59	60	62
Piping Connections	Drain (Natural Drainage)	O.D. / I.D.	mm	Φ 25.4 / 19.4	Φ 25.4 / 19.4	Φ 25.4 / 19.4
	Drain (Using Drain Pump)	O.D. / I.D.	mm	Φ 32.0 / 26.0	Φ 32.0 / 26.0	Φ 32.0 / 26.0

OUTDOOR				UUB1.U20	UUC1.U40
Power Supply			Ø, V, Hz	1, 220-240, 50	1, 220-240, 50
Circuit Breaker		Min	A	20	25
Power Supply Cable (included Earth)			No x mm²	3C x 2.5	3C x 2.5
Dimensions	Net	W x H x D	mm	870 x 650 x 330	950 x 834 x 330
Weight	Net		kg	44.5	57.7
Compressor	Type		-	Twin Rotary	Twin Rotary
Refrigerant	Type		-	R32	R32
	GWP (Global Warming Potential)		-	675	675
	Precharged Amount		kg	1.2	1.9
	t-CO <sub>2</sub> eq.		-	0.81	1.283
	Additional Charge (After 7.5m)		g/m	20	40
Fan	Air Flow Rate	Rated	m³/min x No.	50 x 1	58 x 1
Total Piping Length		Min / Max	m	5 / 30	5 / 50
Piping Elevation	IDU - ODU	Max	m	30	30

# CEILING CONCEALED DUCT



## STANDARD INVERTER (R32)

MID STATIC PRESSURE  
- UM36F / UM42F / UM48F / UM60F



LG participates in the ECP programme for EUROVENT AC program.  
Check ongoing validity of certification  
: www.eurovent-certification.com

UUD1.U30



COMBINATION				36	42	48	60
Capacity	Cooling	Min - Rated - Max	kW	3.8 / 9.5 / 12.5	4.8 / 12.0 / 14.0	5.4 / 13.4 / 15.7	5.8 / 14.6 / 15.8
	Heating	Min - Rated - Max	kW	4.3 / 10.8 / 13.4	5.4 / 13.5 / 15.8	6.2 / 15.5 / 17.5	6.7 / 16.8 / 18.1
Power Input (Set)	Cooling	Min - Rated - Max	kW	0.50 / 2.50 / 3.80	0.70 / 3.48 / 4.52	0.90 / 4.32 / 5.62	1.00 / 4.95 / 5.54
	Heating	Min - Rated - Max	kW	0.60 / 2.77 / 3.77	0.80 / 3.74 / 4.86	0.90 / 4.31 / 5.26	0.90 / 4.60 / 5.29
Running Current	Cooling	Rated	A	11.1	15.3	19.0	21.6
	Heating	Rated	A	12.6	16.4	18.4	20.4
EER / COP			kWh/kWh	3.80 / 3.90	3.45 / 3.61	3.10 / 3.60	2.95 / 3.65
SEER / SCOP			kWh/kWh	5.80 / 3.90	5.60 / 3.90	5.80 / 4.00	5.60 / 4.00
Pdesign	Cooling @ 35°C		kW	9.5	12.0	13.4	14.6
	Heating @ -10°C		kW	9.5	9.5	9.5	9.5
Seasonal Energy Label	Cooling / Heating		-	A+ / A	A+ / A	- / -	- / -
Annual Energy Consumption	Cooling / Heating		kWh	573 / 3,410	750 / 3,410	1,386 / 3,325	1,564 / 3,325
Dehumidification Rate			l/h	2.9	4.4	4.8	4.7
ODU Sound Pressure Level	Cooling / Heating	Rated	dB(A)	50 / 50	51 / 52	52 / 53	54 / 54
ODU Sound Power Level	Cooling	Rated	dB(A)	66	69	69	71
Piping Connections	Liquid		mm (inch)	φ 9.52 (3/8)	φ 9.52 (3/8)	φ 9.52 (3/8)	φ 9.52 (3/8)
	Gas		mm (inch)	φ 15.88 (5/8)	φ 15.88 (5/8)	φ 15.88 (5/8)	φ 15.88 (5/8)
	Connections Method		-	Flared	Flared	Flared	Flared
Operation Range (Outdoor)	Cooling	Min - Max	°C	-20 - 52	-20 - 52	-20 - 52	-20 - 52
	Heating	Min - Max	°C	-25 - 18	-25 - 18	-25 - 18	-25 - 18
<b>INDOOR</b>				<b>UM36F.N20</b>	<b>UM42F.N20</b>	<b>UM48F.N30</b>	<b>UM60F.N30</b>
Power Supply			Ø, V, Hz	1, 220-240, 50	1, 220-240, 50	1, 220-240, 50	1, 220-240, 50
Power Input (IDU)		H / M / L	W	183 / 134 / 101	266 / 200 / 145	242 / 159 / 124	342 / 287 / 242
Air Flow Rate		H / M / L	m <sup>3</sup> /min	32 / 28 / 24	38 / 33 / 28	40 / 34 / 28	50 / 45 / 40
Dimensions	Body	W x H x D	mm	1,250 x 270 x 700	1,250 x 270 x 700	1,250 x 360 x 700	1,250 x 360 x 700
Weight	Body		kg	38.5	38.5	43.5	43.5
Sound Pressure Level	Cooling	H / M / L	dB(A)	36 / 34 / 33	38 / 36 / 34	39 / 38 / 36	42 / 40 / 39
Sound Power Level	Cooling	Max.	dB(A)	60	62	65	66
Piping Connections	Drain (Natural Drainage)	O.D. / I.D.	mm	φ 25.4 / 19.4	φ 25.4 / 19.4	φ 25.4 / 19.4	φ 25.4 / 19.4
	Drain (Using Drain Pump)	O.D. / I.D.	mm	φ 32.0 / 26.0	φ 32.0 / 26.0	φ 32.0 / 26.0	φ 32.0 / 26.0
<b>OUTDOOR</b>				<b>UUD1.U30</b>			
Power Supply			Ø, V, Hz	1, 220-240, 50			
Circuit Breaker		Min	A	40			
Power Supply Cable (included Earth)			No x mm <sup>3</sup>	3C x 6.0			
Dimensions	Net	W x H x D	mm	950 x 1,380 x 330			
Weight	Net		kg	85			
Compressor	Type		-	Inverter Scroll			
Refrigerant	Type		-	R32			
	GWP (Global Warming Potential)		-	675			
	Precharged Amount		kg	3.0			
	t-CO <sub>2</sub> eq.		-	2.025			
	Additional Charge (After 7.5m)		g/m	40			
Fan	Air Flow Rate	Rated	m <sup>3</sup> /min x No.	55 x 2			
Total Piping Length		Min / Max	m	5 / 85			
Piping Elevation	IDU - ODU	Max	m	30			

# CEILING CONCEALED DUCT



## STANDARD INVERTER (R32)

MID STATIC PRESSURE  
- UM 36F / UM42F / UM48F / UM60F



LG participates in the ECP programme for EUROVENT AC program.  
Check ongoing validity of certification  
: www.eurovent-certification.com

UUD3.U30



COMBINATION				36	42	48	60
Capacity	Cooling	Min - Rated - Max	kW	3.8 / 9.5 / 12.5	4.8 / 12.0 / 14.0	5.4 / 13.4 / 15.7	5.8 / 14.6 / 15.8
	Heating	Min - Rated - Max	kW	4.3 / 10.8 / 13.4	5.4 / 13.5 / 15.8	6.2 / 15.5 / 17.5	6.7 / 16.8 / 18.1
Power Input (Set)	Cooling	Min - Rated - Max	kW	0.50 / 2.50 / 3.80	0.70 / 3.48 / 4.52	0.90 / 4.32 / 5.62	1.00 / 4.95 / 5.54
	Heating	Min - Rated - Max	kW	0.60 / 2.77 / 3.77	0.80 / 3.74 / 4.86	0.90 / 4.31 / 5.26	0.90 / 4.60 / 5.29
Running Current	Cooling	Rated	A	4.0	5.5	6.8	7.7
	Heating	Rated	A	4.5	5.9	6.5	7.2
EER / COP			kWh/kWh	3.80 / 3.90	3.45 / 3.61	3.10 / 3.60	2.95 / 3.65
SEER / SCOP			kWh/kWh	5.8 / 3.9	5.6 / 3.9	5.8 / 4.0	5.6 / 4.0
Pdesign	Cooling @ 35°C		kW	9.5	12	13.4	14.6
	Heating @ -10°C		kW	9.5	9.5	9.5	9.5
Seasonal Energy Label	Cooling / Heating		-	A+ / A	A+ / A	- / -	- / -
Annual Energy Consumption	Cooling / Heating		kWh	573 / 3,410	750 / 3,410	1,386 / 3,325	1,564 / 3,325
Dehumidification Rate			l/h	2.9	4.4	4.8	4.7
ODU Sound Pressure Level	Cooling / Heating	Rated	dB(A)	50 / 50	51 / 52	52 / 53	54 / 54
ODU Sound Power Level	Cooling	Rated	dB(A)	66	69	69	71
Piping Connections	Liquid		mm (inch)	φ 9.52 (3/8)	φ 9.52 (3/8)	φ 9.52 (3/8)	φ 9.52 (3/8)
	Gas		mm (inch)	φ 15.88 (5/8)	φ 15.88 (5/8)	φ 15.88 (5/8)	φ 15.88 (5/8)
	Connections Method		-	Flared	Flared	Flared	Flared
Operation Range (Outdoor)	Cooling	Min - Max	°C	-20 - 52	-20 - 52	-20 - 52	-20 - 52
	Heating	Min - Max	°C	-25 - 18	-25 - 18	-25 - 18	-25 - 18
<b>INDOOR</b>				<b>UM36F.N20</b>	<b>UM42F.N20</b>	<b>UM48F.N30</b>	<b>UM60F.N30</b>
Power Supply			Ø, V, Hz	1, 220-240, 50	1, 220-240, 50	1, 220-240, 50	1, 220-240, 50
Power Input (IDU)		H / M / L	W	183 / 134 / 101	266 / 200 / 145	242 / 159 / 124	342 / 287 / 242
Air Flow Rate		H / M / L	m <sup>3</sup> /min	32 / 28 / 24	38 / 33 / 28	40 / 34 / 28	50 / 45 / 40
Dimensions	Body	W x H x D	mm	1,250 x 270 x 700	1,250 x 270 x 700	1,250 x 360 x 700	1,250 x 360 x 700
Weight	Body		kg	38.5	38.5	43.5	43.5
Sound Pressure Level	Cooling	H / M / L	dB(A)	36 / 34 / 33	38 / 36 / 34	39 / 38 / 36	42 / 40 / 39
Sound Power Level	Cooling	Max.	dB(A)	60	62	65	66
Piping Connections	Drain (Natural Drainage)	O.D. / I.D.	mm	φ 25.4 / 19.4	φ 25.4 / 19.4	φ 25.4 / 19.4	φ 25.4 / 19.4
	Drain (Using Drain Pump)	O.D. / I.D.	mm	φ 32.0 / 26.0	φ 32.0 / 26.0	φ 32.0 / 26.0	φ 32.0 / 26.0
<b>OUTDOOR</b>				<b>UUD3.U30</b>			
Power Supply			Ø, V, Hz	3, 380-415, 50			
Circuit Breaker		Min	A	20			
Power Supply Cable (included Earth)			No x mm <sup>3</sup>	5C x 2.5			
Dimensions	Net	W x H x D	mm	950 x 1,380 x 330			
Weight	Net		kg	85			
Compressor	Type		-	Inverter Scroll			
Refrigerant	Type		-	R32			
	GWP (Global Warming Potential)		-	675			
	Precharged Amount		kg	3.0			
	t-CO <sub>2</sub> eq.		-	2.025			
	Additional Charge (After 7.5m)		g/m	40			
Fan	Air Flow Rate	Rated	m <sup>3</sup> /min x No.	55 x 2			
Total Piping Length		Min / Max	m	5 / 85			
Piping Elevation	IDU - ODU	Max	m	30			

# CEILING CONCEALED DUCT



## COMPACT INVERTER (R32)

LOW STATIC PRESSURE  
- CL18F / CL24F



LG participates in the ECP programme for EUROVENT AC program.  
Check ongoing validity of certification  
: www.eurovent-certification.com

UUA1.ULO      UUB1.U20



COMBINATION		18		24	
Capacity	Cooling	Min - Rated - Max	kW	1.8 / 4.7 / 5.1	2.7 / 6.8 / 7.5
	Heating	Min - Rated - Max	kW	2.1 / 5.2 / 5.7	3.0 / 7.5 / 8.6
Power Input (Set)	Cooling	Min - Rated - Max	kW	0.34 / 1.62 / 1.99	0.40 / 2.12 / 2.54
	Heating	Min - Rated - Max	kW	0.30 / 1.53 / 1.99	0.50 / 2.41 / 3.13
Running Current	Cooling	Rated	A	7.2	9.3
	Heating	Rated	A	6.8	10.5
EER / COP			kWh/kWh	2.90 / 3.40	3.21 / 3.11
SEER / SCOP			kWh/kWh	5.1 / 3.8	6.0 / 4.1
Pdesign	Cooling @ 35°C		kW	4.7	6.8
	Heating @ -10°C		kW	2.7	4.2
Seasonal Energy Label	Cooling / Heating			-	A+ / A+
Annual Energy Consumption	Cooling / Heating		kWh	323 / 995	397 / 1,434
Dehumidification Rate			l/h	1.5	2.4
ODU Sound Pressure Level	Cooling / Heating	Rated	dB(A)	49 / 52	48 / 53
ODU Sound Power Level	Cooling	Rated	dB(A)	65	65
Piping Connections	Liquid		mm (inch)	φ 6.35 (1/4)	φ 9.52 (3/8)
	Gas		mm (inch)	φ 12.7 (1/2)	φ 15.88 (5/8)
	Connections Method		-	Flared	Flared
Operation Range (Outdoor)	Cooling	Min - Max	°C	-10 - 50	-10 - 48
	Heating	Min - Max	°C	-10 - 18	-15 - 18

INDOOR				CL18F.N60		CL24F.N30	
Power Supply		Ø, V, Hz		1, 220-240, 50	1, 220-240, 50		
Power Input (IDU)	H / M / L	W		100 / 90 / 80	150 / 130 / 110		
Air Flow Rate	H / M / L	m³/min		15 / 12 / 10	20 / 16 / 12		
Dimensions	Body	W x H x D	mm	1,100 x 190 x 460	1,100 x 190 x 700		
Weight	Body		kg	20.9	26		
Sound Pressure Level	Cooling	H / M / L	dB(A)	34 / 31 / 29	39 / 35 / 32		
Sound Power Level	Cooling	Max.	dB(A)	56	58		
Piping Connections	Drain	O.D. / I.D.	mm	φ 32.0 / 26.0	φ 32.0 / 26.0		

OUTDOOR				UUA1.ULO		UUB1.U20	
Power Supply		Ø, V, Hz		1, 220-240, 50	1, 220-240, 50		
Circuit Breaker	Min	A		15	20		
Power Supply Cable (included Earth)		No x mm²		3C x 2.5	3C x 2.5		
Dimensions	Net	W x H x D	mm	770 x 545 x 288	870 x 650 x 330		
Weight	Net		kg	33.3	44.5		
Compressor	Type		-	Twin Rotary	Twin Rotary		
Refrigerant	Type		-	R32	R32		
	GWP (Global Warming Potential)		-	675	675		
	Precharged Amount		kg	1.0	1.2		
	t-CO <sub>2</sub> eq.		-	0.675	0.81		
	Additional Charge (After 7.5m)		g/m	20	40		
Fan	Air Flow Rate	Rated	m³/min x No.	28 x 1	50 x 1		
Total Piping Length		Min / Max	m	5 / 30	5 / 35		
Piping Elevation	IDU - ODU	Max	m	30	30		

# CEILING CONCEALED DUCT



## COMPACT INVERTER (R32)

MID STATIC PRESSURE  
- CM18F / CM24F / UM30F / UM36F



LG participates in the ECP programme for EUROVENT AC program.  
Check ongoing validity of certification  
: www.eurovent-certification.com

UUA1.ULO      UUB1.U20      UUC1.U40



COMBINATION		18		24		30		36	
Capacity	Cooling	Min - Rated - Max	kW	1.8 / 5.0 / 5.6	2.7 / 6.8 / 7.5	3.0 / 7.5 / 8.3	3.8 / 9.5 / 10.5		
	Heating	Min - Rated - Max	kW	2.2 / 5.5 / 6.7	3.0 / 7.4 / 8.5	3.2 / 8.0 / 8.8	4.3 / 10.8 / 11.5		
Power Input (Set)	Cooling	Min - Rated - Max	kW	0.35 / 1.67 / 1.92	0.50 / 2.34 / 2.81	0.50 / 2.57 / 3.08	0.60 / 3.16 / 3.86		
	Heating	Min - Rated - Max	kW	0.32 / 1.58 / 1.77	0.40 / 2.17 / 2.82	0.50 / 2.25 / 2.93	0.60 / 3.03 / 3.48		
Running Current	Cooling	Rated	A	7.4	10.3	11.0	14.0		
	Heating	Rated	A	7.0	9.7	9.7	13.4		
EER / COP			kWh/kWh	3.00 / 3.50	2.91 / 3.41	2.92 / 3.56	3.01 / 3.57		
SEER / SCOP			kWh/kWh	6.1 / 3.8	5.8 / 4.1	5.6 / 3.9	5.9 / 4.0		
Pdesign	Cooling @ 35°C		kW	5	6.8	7.5	9.5		
	Heating @ -10°C		kW	2.8	4.1	4.3	5.5		
Seasonal Energy Label	Cooling / Heating			-	A++ / A+	A+ / A+	A+ / A+		
Annual Energy Consumption	Cooling / Heating		kWh	287 / 1,032	410 / 1,400	469 / 1,544	564 / 1,924		
Dehumidification Rate			l/h	1.2	2.5	2.6	3.2		
ODU Sound Pressure Level	Cooling / Heating	Rated	dB(A)	49 / 52	48 / 53	50 / 54	54 / 56		
ODU Sound Power Level	Cooling	Rated	dB(A)	65	65	67	70		
Piping Connections	Liquid		mm (inch)	φ 6.35 (1/4)	φ 9.52 (3/8)	φ 9.52 (3/8)	φ 9.52 (3/8)		
	Gas		mm (inch)	φ 12.7 (1/2)	φ 15.88 (5/8)	φ 15.88 (5/8)	φ 15.88 (5/8)		
	Connections Method		-	Flared	Flared	Flared	Flared		
Operation Range (Outdoor)	Cooling	Min - Max	°C	-10 - 50	-10 - 48	-10 - 48	-20 - 50		
	Heating	Min - Max	°C	-10 - 18	-15 - 18	-15 - 18	-15 - 18		

INDOOR				CM18F.N10		CM24F.N10		UM30F.N10		UM36F.N20	
Power Supply		Ø, V, Hz		1, 220-240, 50	1, 220-240, 50	1, 220-240, 50	1, 220-240, 50	1, 220-240, 50	1, 220-240, 50		
Power Input (IDU)	H / M / L	W		150 / 130 / 110	180 / 150 / 130	220 / 200 / 180	183 / 134 / 101				
Air Flow Rate	H / M / L	m³/min		16.5 / 14.5 / 13	18 / 16.5 / 14.5	22 / 20 / 18	32 / 28 / 24				
Dimensions	Body	W x H x D	mm	900 x 270 x 700	900 x 270 x 700	900 x 270 x 700	1,250 x 270 x 700				
Weight	Body		kg	24.6	24.6	26.2	38.5				
Sound Pressure Level	Cooling	H / M / L	dB(A)	34 / 32 / 30	35 / 34 / 32	37 / 35 / 34	36 / 34 / 33				
Sound Power Level	Cooling	Max.	dB(A)	59	60	62	60				
Piping Connections	Drain(Natural Drainage)	O.D. / I.D.	mm	φ 25.4 / 19.4	φ 25.4 / 19.4	φ 25.4 / 19.4	φ 25.4 / 19.4				
	Drain(Using Drain Pump)	O.D. / I.D.	mm	φ 32.0 / 26.0	φ 32.0 / 26.0	φ 32.0 / 26.0	φ 32.0 / 26.0				

OUTDOOR				UUA1.ULO		UUB1.U20		UUC1.U40	
Power Supply		Ø, V, Hz		1, 220-240, 50	1, 220-240, 50	1, 220-240, 50	1, 220-240, 50		
Circuit Breaker	Min	A		15	20	25			
Power Supply Cable (included Earth)		No x mm²		3C x 2.5	3C x 2.5	3C x 2.5			
Dimensions	Net	W x H x D	mm	770 x 545 x 288	870 x 650 x 330	950 x 834 x 330			
Weight	Net		kg	33.3	44.5	57.7			
Compressor	Type		-	Twin Rotary	Twin Rotary	Twin Rotary			
Refrigerant	Type		-	R32	R32	R32			
	GWP (Global Warming Potential)		-	675	675	675			
	Precharged Amount		kg	1	1.2	1.9			
	t-CO <sub>2</sub> eq.		-	0.675	0.81	1.283			
	Additional Charge (After 7.5m)		g/m	20	40	40			
Fan	Air Flow Rate	Rated	m³/min x No.	28 x 1	50 x 1	58 x 1			
Total Piping Length		Min / Max	m	5 / 30	5 / 35	5 / 50			
Piping Elevation	IDU - ODU	Max	m	30	30	30			

# CEILING CONCEALED DUCT



## STANDARD INVERTER (R410A)

### HIGH STATIC PRESSURE - UB70 / UB85



LG participates in the ECP programme for EUROVENT AC program.  
Check ongoing validity of certification  
: www.eurovent-certification.com



### UU70W



### UU85W



INDOOR				UB70.N94	UB85.N94
Capacity	Cooling	Min / Nom / Max	kW	7.6 / 19.0 / 20.9	9.2 / 23.0 / 25.3
	Heating	Min / Nom / Max	kW	9.0 / 22.4 / 24.6	10.8 / 27.0 / 29.7
Low Temperature Capacity	Heating -7°C	Max	kW	18.0	24.0
		Nom	kW	6.69	8.19
Power Input (Set)	Heating	Nom	kW	6.4	8.31
		Min / Max (Nom ESP)	W	550 / 760	610 / 920
Running Current	Cooling / Heating	Nom	A	11.5 / 10.7	13.5 / 13.6
Power Supply			Ø, V, Hz	1, 220-240, 50	1, 220-240, 50
EER				2.84	2.81
COP				3.50	3.25
SEER				4.60	4.80
SCOP				3.53	3.51
Pdesign (@ -10°C)			kW	13.4	18.5
Seasonal Energy Label	Cooling / Heating			-	-
Annual Energy Consumption	Cooling / Heating		kWh	-	-
		Liquid	mm (inch)	Ø9.52 (3/8)	Ø12.7 (1/2)
Piping Connection	Gas		mm (inch)	Ø25.4 (1/1)	Ø22.2 (7/8)
	Drain	O.D. / I.D.	mm	32 / 25	32 / 25
		High / Medium / Low	m³/min	70.0 / 65.0 / 60.0	80.0 / 72.0 / 64.0
Air Flow Rate					
Sound Pressure	Cooling	High / Medium / Low	dB(A)	43 / 41 / 40	43 / 41 / 40
Sound Power	Cooling	Max	dB(A)	73	75
Dehumidification Rate			l/h	1.81 (4.2)	5.14 (11.9)
Dimensions	Body	W x H x D	mm	1,563 x 460 x 688	1,563 x 460 x 688
Net Weight	Body		kg	90.0	90.0
External Static Pressure		Min / Max	mmAq(Pa)	6 / 25 (60 / 250)	6 / 25 (60 / 250)
OUTDOOR				UU70W.U34	UU85W.U74
Compressor	Type			Hermetically Sealed Scroll	Hermetically Sealed Scroll
Airflow Rate		Nom	m³/min	110	190
Sound Pressure	Cooling	Nom	dB(A)	55	59
	Heating	Nom	dB(A)	58	60
Sound Power	Cooling	Max	dB(A)	75	75
Dimensions	W x H x D		mm	950 x 1,380 x 330	1,090 x 1,625 x 380
Net Weight			kg	110	144.0
Refrigerant	Type			R410A	R410A
	Charge		g	5,200	5,500
	Additional Charge		g/m	70	70
	GWP			2087.5	2087.5
	TCO2eq			10.9	11.5
Operation Range (Outdoor)	Cooling	Min / Max	°C DB	-20 / 48	-20 / 48
	Heating	Min / Max	°C WB	-18 / 18	-18 / 18
Power Supply			Ø, V, Hz	3, 380-415, 50	3, 380-415, 50
Power Supply Cable			No. x mm²	5C x 2.5	5C x 2.5
Transmission Cable			No. x mm²	4C x 1.0	4C x 1.0
Circuit Breaker			A	30	30
Piping Length Total		Min / Max	m	5 / 7.5	5 / 7.5
Piping Elevation Difference	IDU - ODU	Max	m	30	30
Piping Connection	Liquid		mm (inch)	Ø9.53 (3/8)	Ø12.7 (1/2)
	Gas		mm (inch)	Ø25.4 (1/1)	Ø22.2 (7/8)

Note :

- Due to our policy of innovation some specifications may be changed without notification.
- Performances are based on the following conditions (It is accordance with EN14511)
  - Cooling : Indoor Ambient Temp. 27°CDB / 19°CWB, Outdoor Ambient Temp. 35°CDB / 24°CWB
  - Heating : Indoor Ambient Temp. 20°CDB / 15°CWB, Outdoor Ambient Temp. 7°CDB / 6°CWB
  - Interconnected Pipe is standard length and difference of Elevation (Outdoor - Indoor Unit) is 0m.
- Sound Level Values are measured at Noise Measuring chamber accordance with standard. Therefore, these values depend on the ambient conditions and values are normally higher in actual operation
- This product contains fluorinated greenhouse gases (R410A)

# CEILING SUSPENDED UNIT



# CEILING SUSPENDED UNIT

## Differentiated Design

Modern elegance design with V-shape and black vane is appropriate for any commercial space. It received iF Design Award.



## Powerful Cooling & Heating

High ceiling mode provides powerful cooling and heating up to 4.2m in height from floor, 15m away from ceiling.



With enlarged outlet space, optimized the Air flow Path and improved Heat Exchanger's performance

### • Outlet Space

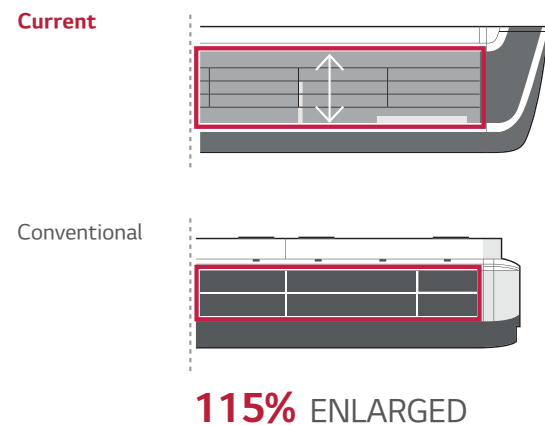

**115% ENLARGED**

### • Optimized the Air flow Path

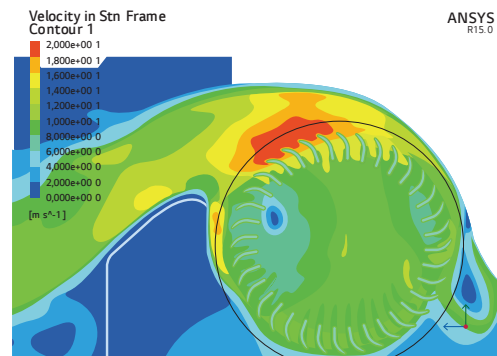

**105% IMPROVED**

# CEILING SUSPENDED UNIT

## One Touch & 2 Piece Filter

Easy in / out filter structure as well as a simplified two-piece filter, which slides out for easy cleaning and maintenance.

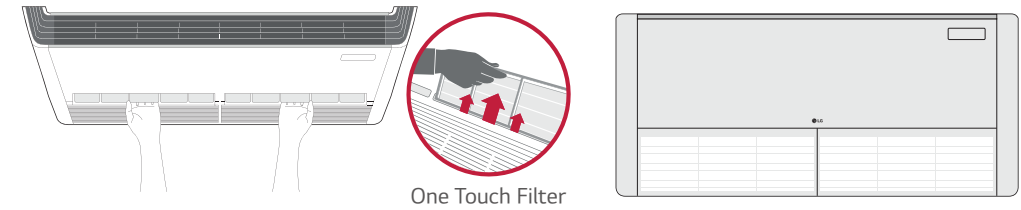

## Two Thermistors Control

Users can purchase a wired remote controller that includes a second thermistor, allowing for temperature checks from multiple locations.

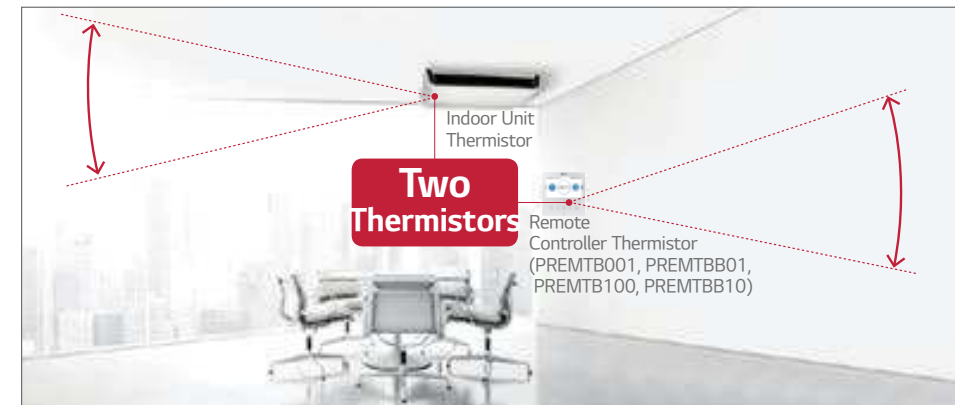

## Easy installation

Installation speed and ease is improved by reducing the total number of screws used and placing the screws on the easily accessible front panel.

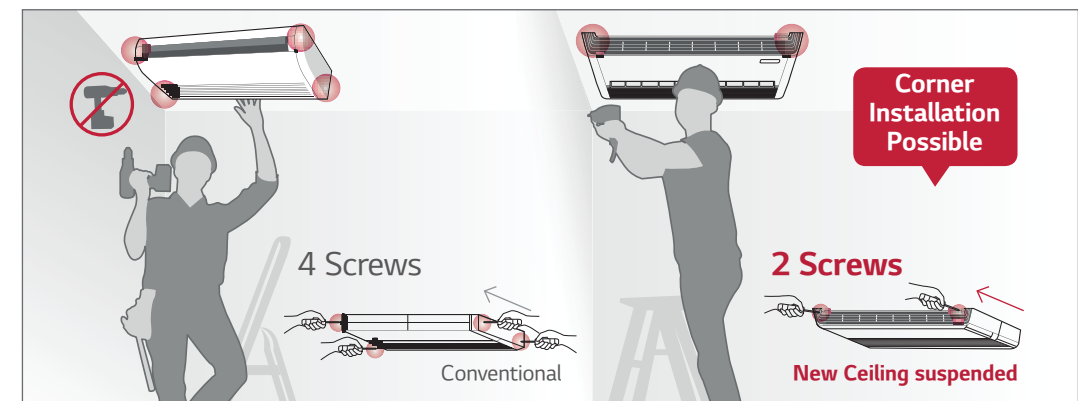



## CEILING SUSPENDED UNIT



## H-INVERTER (R32)

UV18FH / UV24FH / UV30FH



LG participates in the ECP programme for EUROVENT AC program.  
Check ongoing validity of certification  
: www.eurovent-certification.com

UUB1.U20

UUC1.U40



COMBINATION				18	24	30
Capacity	Cooling	Min - Rated - Max	kW	2.0 / 5.0 / 6.0	2.7 / 6.8 / 8.3	3.2 / 8.0 / 9.5
	Heating	Min - Rated - Max	kW	2.3 / 5.8 / 7.0	3.0 / 7.5 / 9.4	3.6 / 8.9 / 10.6
Power Input (Set)	Cooling	Min - Rated - Max	kW	0.30 / 1.28 / 1.73	0.40 / 1.80 / 2.50	0.50 / 2.35 / 3.13
	Heating	Min - Rated - Max	kW	0.30 / 1.58 / 2.13	0.40 / 1.82 / 2.62	0.50 / 2.39 / 3.27
Running Current	Cooling	Rated	A	7.3	8	10.4
	Heating	Rated	A	8	8.1	10.6
EER / COP			kWh/kWh	3.90 / 3.67	3.77 / 4.11	3.41 / 3.72
SEER / SCOP			kWh/kWh	7.6 / 4.4	7.9 / 4.6	7.2 / 4.6
Pdesign	Cooling @ 35°C		kW	5	6.8	8
	Heating @ -10°C		kW	4.3	5.4	5.4
Seasonal Energy Label	Cooling / Heating			A++ / A+	A++ / A++	A++ / A++
Annual Energy Consumption	Cooling / Heating		kWh	230 / 1,368	301 / 1,644	389 / 1,644
Dehumidification Rate			l/h	1.9	2.0	2.8
ODU Sound Pressure Level	Cooling / Heating	Rated	dB(A)	47 / 52	48 / 52	50 / 52
ODU Sound Power Level	Cooling	Rated	dB(A)	63	65	68
Piping Connections	Liquid		mm (inch)	φ 6.35 (1/4)	φ 9.52 (3/8)	φ 9.52 (3/8)
	Gas		mm (inch)	φ 12.7 (1/2)	φ 15.88 (5/8)	φ 15.88 (5/8)
Connections Method				Flared	Flared	Flared
Operation Range (Outdoor)	Cooling	Min - Max	°C	-15 - 50	-20 - 50	-20 - 50
	Heating	Min - Max	°C	-20 - 18	-20 - 18	-20 - 18

INDOOR				UV18FH.N10	UV24FH.N20	UV30FH.N20
Power Supply			Ø, V, Hz	1, 220-240, 50	1, 220-240, 50	1, 220-240, 50
Power Input (IDU)		H / M / L	W	17 / 15 / 13	35 / 32 / 27	35 / 32 / 27
Air Flow Rate		H / M / L	m <sup>3</sup> / min	12.5 / 11 / 10	23 / 21 / 19	23 / 21 / 19
Dimensions	Body	W x H x D	mm	1,200 x 235 x 690	1,600 x 235 x 690	1,600 x 235 x 690
Weight	Body		kg	28.7	37.4	37.4
Sound Pressure Level	Cooling	H / M / L	dB (A)	41 / 39 / 38	43 / 42 / 40	43 / 42 / 40
Sound Power Level	Cooling	Max.	dB (A)	55	60	60
Piping Connections	Drain(Natural Drainage)	O.D. / I.D.	mm	φ 25.0 / 20.5	φ 25.0 / 20.5	φ 25.0 / 20.5
	Drain(Using Drain Pump)	O.D. / I.D.	mm	φ 32.0 / 26.0	φ 32.0 / 26.0	φ 32.0 / 26.0

OUTDOOR				UUB1.U20	UUC1.U40
Power Supply			Ø, V, Hz	1, 220-240, 50	1, 220-240, 50
Circuit Breaker		Min	A	20	25
Power Supply Cable (included Earth)			No x mm <sup>3</sup>	3C x 2.5	3C x 2.5
Dimensions	Net	W x H x D	mm	870 x 650 x 330	950 x 834 x 330
Weight	Net		kg	44.5	57.7
Compressor	Type			Twin Rotary	Twin Rotary
	Type			R32	R32
Refrigerant	GWP (Global Warming Potential)			675	675
	Precharged Amount		kg	1.2	1.9
	t-CO <sub>2</sub> eq.			0.81	1.283
	Additional Charge (After 7.5m)		g / m	20	40
Fan	Air Flow Rate	Rated	m <sup>3</sup> / min x No.	50 x 1	58 x 1
Total Piping Length		Min / Max	m	5 / 30	5 / 50
Piping Elevation	IDU - ODU	Max	m	30	30

Note :

- Due to our policy of innovation some specifications may be changed without notification.
- Performances are based on the following conditions (It is accordance with EN14511)
  - Cooling : Indoor Ambient Temp. 27°CDB / 19°CWB, Outdoor Ambient Temp. 35°CDB / 24°CWB
  - Heating : Indoor Ambient Temp. 20°CDB / 15°CWB, Outdoor Ambient Temp. 7°CDB / 6°CWB
  - Interconnected Pipe is standard length and difference of Elevation (Outdoor - Indoor Unit) is 0m.
- Sound Level Values are measured at Noise Measuring chamber accordance with standard. Therefore, these values depend on the ambient conditions and values are normally higher in actual operation
- This product contains fluorinated greenhouse gases (R32)

## CEILING SUSPENDED UNIT



## H-INVERTER (R32)

UV36FH / UV42FH



LG participates in the ECP programme for EUROVENT AC program.  
Check ongoing validity of certification  
: www.eurovent-certification.com

UUD1.U30



COMBINATION				36	42
Capacity	Cooling	Min - Rated - Max	kW	3.8 - 9.5 - 12.8	4.8 - 12.1 - 14.5
	Heating	Min - Rated - Max	kW	4.3 - 10.8 - 13.7	5.4 - 13.5 - 16.2
Power Input (Set)	Cooling	Min - Rated - Max	kW	0.5 - 2.50 - 3.75	0.7 - 3.64 - 4.91
	Heating	Min - Rated - Max	kW	0.5 - 2.54 - 3.56	0.8 - 3.75 - 4.88
Running Current	Cooling	Rated	A	11.1	16
	Heating	Rated	A	11.4	16.5
EER / COP			kWh/kWh	3.80 / 4.25	3.32 / 3.60
SEER / SCOP			kWh/kWh	6.70 / 4.30	6.60 / 4.30
Pdesign	Cooling @ 35°C		kW	9.5	12.1
	Heating @ -10°C		kW	9.5	9.5
Seasonal Energy Label	Cooling / Heating			A++ / A+	- / -
Annual Energy Consumption	Cooling / Heating		kWh	496 / 3,093	1,100 / 3,093
Dehumidification Rate			l/h	3.6	5.52
ODU Sound Pressure Level	Cooling / Heating	Rated	dB(A)	50 / 50	51 / 52
ODU Sound Power Level	Cooling	Rated	dB(A)	66	69
Piping Connections	Liquid		mm (inch)	φ 9.52 (3/8)	φ 9.52 (3/8)
	Gas		mm (inch)	φ 15.88 (5/8)	φ 15.88 (5/8)
Connections Method				Flared	Flared
Operation Range (Outdoor)	Cooling	Min - Max	°C	-20 - 52	-20 - 52
	Heating	Min - Max	°C	-25 - 18	-25 - 18

INDOOR				UV36FH.N20	UV42FH.N20
Power Supply			Ø, V, Hz	1, 220-240, 50	1, 220-240, 50
Power Input (IDU)		H / M / L	W	59 / 40 / 28	59 / 40 / 28
Air Flow Rate		H / M / L	m <sup>3</sup> / min	30 / 25 / 20	30 / 25 / 20
Dimensions	Body	W x H x D	mm	1,600 x 235 x 690	1,600 x 235 x 690
Weight	Body		kg	37.4	37.4
Sound Pressure Level	Cooling	H / M / L	dB (A)	48 / 44 / 40	48 / 44 / 40
Sound Power Level	Cooling	Max.	dB (A)	62	62
Piping Connections	Drain(Natural Drainage)	O.D. / I.D.	mm	φ 25.0 / 20.5	φ 25.0 / 20.5
Piping Connections	Drain(Using Drain Pump)	O.D. / I.D.	mm	φ 32.0 / 26.0	φ 32.0 / 26.0

OUTDOOR				UUD1.U30
Power Supply			Ø, V, Hz	1, 220-240, 50
Circuit Breaker		Min	A	40
Power Supply Cable (included Earth)			No x mm <sup>3</sup>	3C x 6.0
Dimensions	Net	W x H x D	mm	950 x 1,380 x 330
Weight	Net		kg	85
Compressor	Type			Inverter Scroll
	Type			R32
Refrigerant	GWP (Global Warming Potential)			675
	Precharged Amount		kg	3.0
	t-CO <sub>2</sub> eq.			2.025
	Additional Charge (After 7.5m)		g/m	40
Fan	Air Flow Rate	Rated	m <sup>3</sup> / min x No.	55 x 2
Total Piping Length		Min / Max	m	5 / 85
Piping Elevation	IDU - ODU	Max	m	30

Note :

- Due to our policy of innovation some specifications may be changed without notification.
- Performances are based on the following conditions (It is accordance with EN14511)
  - Cooling : Indoor Ambient Temp. 27°CDB / 19°CWB, Outdoor Ambient Temp. 35°CDB / 24°CWB
  - Heating : Indoor Ambient Temp. 20°CDB / 15°CWB, Outdoor Ambient Temp. 7°CDB / 6°CWB
  - Interconnected Pipe is standard length and difference of Elevation (Outdoor - Indoor Unit) is 0m.
- Sound Level Values are measured at Noise Measuring chamber accordance with standard. Therefore, these values depend on the ambient conditions and values are normally higher in actual operation
- This product contains fluorinated greenhouse gases (R32)

# CEILING SUSPENDED UNIT



## H-INVERTER (R32)

UV36FH / UV42FH



LG participates in the ECP programme for EUROVENT AC program.  
Check ongoing validity of certification  
: www.eurovent-certification.com



UUD3.U30



COMBINATION				36	42
Capacity	Cooling	Min - Rated - Max	kW	3.8 / 9.5 / 12.8	4.8 / 12.1 / 14.5
	Heating	Min - Rated - Max	kW	4.3 / 10.8 / 13.7	5.4 / 13.5 / 16.2
Power Input (Set)	Cooling	Min - Rated - Max	kW	0.50 / 2.50 / 3.75	0.70 / 3.64 / 4.91
	Heating	Min - Rated - Max	kW	0.50 / 2.54 / 3.56	0.80 / 3.75 / 4.88
Running Current	Cooling	Rated	A	4.0	5.7
	Heating	Rated	A	4.1	5.9
EER / COP			kWh/kWh	3.80 / 4.25	3.32 / 3.60
SEER / SCOP			kWh/kWh	6.7 / 4.3	6.6 / 4.3
Pdesign	Cooling @ 35°C		kW	9.5	12.1
	Heating @ -10°C		kW	9.5	9.5
Seasonal Energy Label	Cooling / Heating			A++ / A+	- / -
Annual Energy Consumption	Cooling / Heating		kWh	496 / 3,093	1,100 / 3,093
Dehumidification Rate			l/h	3.6	5.5
ODU Sound Pressure Level	Cooling / Heating	Rated	dB(A)	50 / 50	51 / 52
ODU Sound Power Level	Cooling	Rated	dB(A)	66	69
Piping Connections	Liquid		mm (inch)	φ 9.52 (3/8)	φ 9.52 (3/8)
	Gas		mm (inch)	φ 15.88 (5/8)	φ 15.88 (5/8)
Connections Method				Flared	Flared
Operation Range (Outdoor)	Cooling	Min - Max	°C	-20 - 52	-20 - 52
	Heating	Min - Max	°C	-25 - 18	-25 - 18
INDOOR				UV36FH.N20	UV42FH.N20
Power Supply			∅, V, Hz	1, 220-240, 50	1, 220-240, 50
Power Input (IDU)		H / M / L	W	59 / 40 / 28	59 / 40 / 28
Air Flow Rate		H / M / L	m <sup>3</sup> /min	30 / 25 / 20	30 / 25 / 20
Dimensions	Body	W x H x D	mm	1,600 x 235 x 690	1,600 x 235 x 690
Weight	Body		kg	37.4	37.4
Sound Pressure Level	Cooling	H / M / L	dB (A)	48 / 44 / 40	48 / 44 / 40
Sound Power Level	Cooling	Max.	dB (A)	62	62
Piping Connections	Drain(Natural Drainage)	O.D. / I.D.	mm	φ 25.0 / 20.5	φ 25.0 / 20.5
	Drain(Using Drain Pump)	O.D. / I.D.	mm	φ 32.0 / 26.0	φ 32.0 / 26.0
OUTDOOR				UUD3.U30	
Power Supply			∅, V, Hz	3, 380-415, 50	
Circuit Breaker		Min	A	20	
Power Supply Cable (included Earth)			No x mm <sup>3</sup>	5C x 2.5	
Dimensions	Net	W x H x D	mm	950 x 1,380 x 330	
Weight	Net		kg	85	
Compressor	Type			Inverter Scroll	
	Type			R32	
Refrigerant	GWP (Global Warming Potential)			675	
	Precharged Amount		kg	3.0	
	t-CO <sub>2</sub> eq.			2.025	
	Additional Charge (After 7.5m)		g/m	40	
Fan	Air Flow Rate	Rated	m <sup>3</sup> /min x No.	55 x 2	
Total Piping Length		Min / Max	m	5 / 85	
Piping Elevation	IDU - ODU	Max	m	30	

- Note :
- Due to our policy of innovation some specifications may be changed without notification.
  - Performances are based on the following conditions (It is accordance with EN14511)
    - Cooling : Indoor Ambient Temp. 27°CDB / 19°CWB, Outdoor Ambient Temp. 35°CDB / 24°CWB
    - Heating : Indoor Ambient Temp. 20°CDB / 15°CWB, Outdoor Ambient Temp. 7°CDB / 6°CWB
    - Interconnected Pipe is standard length and difference of Elevation (Outdoor - Indoor Unit) is 0m.
  - Sound Level Values are measured at Noise Measuring chamber accordance with standard. Therefore, these values depend on the ambient conditions and values are normally higher in actual operation
  - This product contains fluorinated greenhouse gases (R32)

# CEILING SUSPENDED UNIT



## STANDARD INVERTER (R32)

UV18F / UV24F / UV30F



LG participates in the ECP programme for EUROVENT AC program.  
Check ongoing validity of certification  
: www.eurovent-certification.com

UUB1.U20

UUC1.U40



COMBINATION				18	24	30
Capacity	Cooling	Min - Rated - Max	kW	2.0 / 5.0 / 5.8	2.7 / 6.7 / 8.0	3.1 / 7.7 / 8.8
	Heating	Min - Rated - Max	kW	2.3 / 5.8 / 6.7	3.0 / 7.5 / 9.0	3.4 / 8.6 / 9.6
Power Input (Set)	Cooling	Min - Rated - Max	kW	0.30 / 1.33 / 1.86	0.40 / 1.99 / 2.69	0.50 / 2.25 / 3.08
	Heating	Min - Rated - Max	kW	0.40 / 1.76 / 2.46	0.40 / 2.2 / 3.08	0.50 / 2.5 / 3.20
Running Current	Cooling	Rated	A	7.5	8.8	10.0
	Heating	Rated	A	8.3	9.8	11.1
EER / COP			kWh/kWh	3.75 / 3.29	3.37 / 3.41	3.42 / 3.44
SEER / SCOP			kWh/kWh	6.6 / 4.3	7.2 / 4.2	6.8 / 4.4
Pdesign	Cooling @ 35°C		kW	5	6.7	7.7
	Heating @ -10°C		kW	4.2	4.9	5.4
Seasonal Energy Label	Cooling / Heating			A++ / A+	A++ / A+	A++ / A+
Annual Energy Consumption	Cooling / Heating		kWh	265 / 1,368	326 / 1,633	396 / 1,718
Dehumidification Rate			l/h	1.8	2.7	3.0
ODU Sound Pressure Level	Cooling / Heating	Rated	dB(A)	47 / 52	48 / 52	50 / 52
ODU Sound Power Level	Cooling	Rated	dB(A)	63	65	68
Piping Connections	Liquid		mm (inch)	φ 6.35 (1/4)	φ 9.52 (3/8)	φ 9.52 (3/8)
	Gas		mm (inch)	φ 12.7 (1/2)	φ 15.88 (5/8)	φ 15.88 (5/8)
Connections Method				Flared	Flared	Flared
Operation Range (Outdoor)	Cooling	Min - Max	°C	-15 - 50	-20 - 50	-20 - 50
	Heating	Min - Max	°C	-20 - 18	-20 - 18	-20 - 18
INDOOR				UV18F.N10	UV24F.N10	UV30F.N10
Power Supply			∅, V, Hz	1, 220-240, 50	1, 220-240, 50	1, 220-240, 50
Power Input (IDU)		H / M / L	W	17 / 15 / 13	33 / 26 / 19	47 / 40 / 33
Air Flow Rate		H / M / L	m <sup>3</sup> /min	13 / 12 / 11	16 / 15 / 14	19 / 17.5 / 16
Dimensions	Body	W x H x D	mm	1,200 x 235 x 690	1,200 x 235 x 690	1,200 x 235 x 690
Weight	Body		kg	27.3	28	28
Sound Pressure Level	Cooling	H / M / L	dB(A)	42 / 40 / 39	46 / 45 / 43	46 / 44 / 43
Sound Power Level	Cooling	Max.	dB(A)	55	61	62
Piping Connections	Drain(Natural Drainage)	O.D. / I.D.	mm	φ 25.0 / 20.5	φ 25.0 / 20.5	φ 25.0 / 20.5
	Drain(Using Drain Pump)	O.D. / I.D.	mm	φ 32.0 / 26.0	φ 32.0 / 26.0	φ 32.0 / 26.0
OUTDOOR				UUB1.U20	UUC1.U40	
Power Supply			∅, V, Hz	1, 220-240, 50		
Circuit Breaker		Min	A	20		
Power Supply Cable (included Earth)			No x mm <sup>3</sup>	3C x 2.5		
Dimensions	Net	W x H x D	mm	870 x 650 x 330		
Weight	Net		kg	44.5		
Compressor	Type			Twin Rotary		
	Type			R32		
Refrigerant	GWP (Global Warming Potential)			675		
	Precharged Amount		kg	1.2		
	t-CO <sub>2</sub> eq.			0.81		
	Additional Charge (After 7.5m)		g/m	20		
Fan	Air Flow Rate	Rated	m <sup>3</sup> /min x No.	50 x 1		
Total Piping Length		Min / Max	m	5 / 30		
Piping Elevation	IDU - ODU	Max	m	30		

- Note :
- Due to our policy of innovation some specifications may be changed without notification.
  - Performances are based on the following conditions (It is accordance with EN14511)
    - Cooling : Indoor Ambient Temp. 27°CDB / 19°CWB, Outdoor Ambient Temp. 35°CDB / 24°CWB
    - Heating : Indoor Ambient Temp. 20°CDB / 15°CWB, Outdoor Ambient Temp. 7°CDB / 6°CWB
    - Interconnected Pipe is standard length and difference of Elevation (Outdoor - Indoor Unit) is 0m.
  - Sound Level Values are measured at Noise Measuring chamber accordance with standard. Therefore, these values depend on the ambient conditions and values are normally higher in actual operation
  - This product contains fluorinated greenhouse gases (R32)

# CEILING SUSPENDED UNIT



## STANDARD INVERTER (R32)

UV36F / UV42F / UV48F / UV60F



LG participates in the ECP programme for EUROVENT AC program.  
Check ongoing validity of certification  
: www.eurovent-certification.com

UUD1.U30



COMBINATION				36	42	48	60	
Capacity	Cooling	Min - Rated - Max	kW	3.8 - 9.5 - 12.5	4.8 - 12.1 - 14.2	5.4 - 13.4 - 15.7	5.8 - 14.4 - 15.6	
	Heating	Min - Rated - Max	kW	4.3 - 10.8 - 13.4	5.4 - 13.5 - 15.8	6.2 - 15.5 - 17.5	6.7 - 16.8 - 18.1	
Power Input (Set)	Cooling	Min - Rated - Max	kW	0.50 - 2.65 - 4.03	0.80 - 3.90 - 5.07	0.90 - 4.50 - 5.85	1.10 - 5.33 - 5.97	
	Heating	Min - Rated - Max	kW	0.50 - 2.60 - 3.54	0.80 - 3.75 - 4.88	0.90 - 4.77 - 5.82	1.10 - 5.60 - 6.44	
Running Current	Cooling	Rated	A	11.7	17.0	19.7	23.6	
	Heating	Rated	A	11.4	16.5	20.6	24.6	
EER / COP				kWh/kWh	3.59 / 4.15	3.10 / 3.60	2.98 / 3.25	2.70 / 3.00
SEER / SCOP				kWh/kWh	6.3 / 4.1	6.3 / 4.1	5.9 / 4.1	5.7 / 4.1
Pdesign	Cooling @ 35°C			kW	9.5	12.1	13.4	14.4
	Heating @ -10°C			kW	9.5	9.5	9.5	9.5
Seasonal Energy Label	Cooling / Heating		-	A++ / A+	- / -	- / -	- / -	
Annual Energy Consumption	Cooling / Heating		kWh	528 / 3,244	1,152 / 3,244	1,363 / 3,244	1,516 / 3,244	
Dehumidification Rate			l/h	3.6	5.5	6.3	7.1	
ODU Sound Pressure Level	Cooling / Heating	Rated	dB(A)	50 / 50	51 / 52	52 / 53	54 / 54	
ODU Sound Power Level	Cooling	Rated	dB(A)	66	69	69	71	
Piping Connections	Liquid			mm (inch)	φ 9.52 (3/8)	φ 9.52 (3/8)	φ 9.52 (3/8)	φ 9.52 (3/8)
	Gas			mm (inch)	φ 15.88 (5/8)	φ 15.88 (5/8)	φ 15.88 (5/8)	φ 15.88 (5/8)
	Connections Method			-	Flared	Flared	Flared	Flared
Operation Range (Outdoor)	Cooling	Min - Max	°C	-20 - 52	-20 - 52	-20 - 52	-20 - 52	
	Heating	Min - Max	°C	-25 - 18	-25 - 18	-25 - 18	-25 - 18	
INDOOR				UV36F.N20	UV42F.N20	UV48F.N20	UV60F.N20	
Power Supply			Ø, V, Hz	1, 220-240, 50	1, 220-240, 50	1, 220-240, 50	1, 220-240, 50	
Power Input (IDU)	H / M / L		W	50 / 35 / 28	50 / 35 / 28	59 / 40 / 28	59 / 40 / 28	
Air Flow Rate	H / M / L		m <sup>3</sup> /min	28 / 24 / 20	28 / 24 / 20	30 / 25 / 20	30 / 25 / 20	
Dimensions	Body	W x H x D	mm	1,600 x 235 x 690	1,600 x 235 x 690	1,600 x 235 x 690	1,600 x 235 x 690	
Weight	Body			kg	36.7	36.7	36.7	
Sound Pressure Level	Cooling	H / M / L	dB(A)	46 / 43 / 40	46 / 43 / 40	48 / 44 / 40	48 / 44 / 40	
Sound Power Level	Cooling	Max.	dB(A)	62	62	63	63	
Piping Connections	Drain(Natural Drainage)	O.D. / I.D.	mm	φ 25.0 / 20.5	φ 25.0 / 20.5	φ 25.0 / 20.5	φ 25.0 / 20.5	
	Drain(Using Drain Pump)	O.D. / I.D.	mm	φ 32.0 / 26.0	φ 32.0 / 26.0	φ 32.0 / 26.0	φ 32.0 / 26.0	
OUTDOOR				UUD1.U30				
Power Supply			Ø, V, Hz	1, 220-240, 50				
Circuit Breaker	Min		A	40				
Power Supply Cable (included Earth)			No x mm <sup>3</sup>	3C x 6.0				
Dimensions	Net	W x H x D	mm	950 x 1,380 x 330				
Weight	Net			kg	85			
Compressor	Type			Inverter Scroll				
	Type			R32				
Refrigerant	GWP (Global Warming Potential)			675				
	Precharged Amount			3.0				
	t-CO <sub>2</sub> eq.			2.025				
	Additional Charge (After 7.5m)			40				
Fan	Air Flow Rate	Rated	m <sup>3</sup> /min x No.	55 x 2				
Total Piping Length	Min / Max		m	5 / 85				
Piping Elevation	IDU - ODU	Max	m	30				

Note :

- Due to our policy of innovation some specifications may be changed without notification.
- Performances are based on the following conditions (It is accordance with EN14511)
  - Cooling : Indoor Ambient Temp. 27°CDB / 19°CWB, Outdoor Ambient Temp. 35°CDB / 24°CWB
  - Heating : Indoor Ambient Temp. 20°CDB / 15°CWB, Outdoor Ambient Temp. 7°CDB / 6°CWB
  - Interconnected Pipe is standard length and difference of Elevation (Outdoor - Indoor Unit) is 0m.
- Sound Level Values are measured at Noise Measuring chamber accordance with standard. Therefore, these values depend on the ambient conditions and values are normally higher in actual operation
- This product contains fluorinated greenhouse gases (R32)

# CEILING SUSPENDED UNIT



## STANDARD INVERTER (R32)

UV36F / UV42F / UV48F / UV60F



LG participates in the ECP programme for EUROVENT AC program.  
Check ongoing validity of certification  
: www.eurovent-certification.com

UUD3.U30



COMBINATION				36	42	48	60	
Capacity	Cooling	Min - Rated - Max	kW	3.8 - 9.5 - 12.5	4.8 - 12.1 - 14.2	5.4 - 13.4 - 15.7	5.8 - 14.4 - 15.6	
	Heating	Min - Rated - Max	kW	4.3 - 10.8 - 13.4	5.4 - 13.5 - 15.8	6.2 - 15.5 - 17.5	6.7 - 16.8 - 18.1	
Power Input (Set)	Cooling	Min - Rated - Max	kW	0.50 - 2.65 - 4.03	0.80 - 3.90 - 5.07	0.90 - 4.50 - 5.85	1.10 - 5.33 - 5.97	
	Heating	Min - Rated - Max	kW	0.50 - 2.60 - 3.54	0.80 - 3.75 - 4.88	0.90 - 4.77 - 5.82	1.10 - 5.60 - 6.44	
Running Current	Cooling	Rated	A	4.2	6.1	7.0	8.2	
	Heating	Rated	A	4.1	5.9	7.3	8.5	
EER / COP				kWh/kWh	3.59 / 4.15	3.10 / 3.60	2.98 / 3.25	2.70 / 3.00
SEER / SCOP				kWh/kWh	6.3 / 4.1	6.3 / 4.1	5.9 / 4.1	5.7 / 4.1
Pdesign	Cooling @ 35°C			kW	9.5	12.1	13.4	14.4
	Heating @ -10°C			kW	9.5	9.5	9.5	9.5
Seasonal Energy Label	Cooling / Heating		-	A++ / A+	- / -	- / -	- / -	
Annual Energy Consumption	Cooling / Heating		kWh	528 / 3,244	1,152 / 3,244	1,363 / 3,244	1,516 / 3,244	
Dehumidification Rate			l/h	3.6	5.5	6.3	7.1	
ODU Sound Pressure Level	Cooling / Heating	Rated	dB(A)	50 / 50	51 / 52	52 / 53	54 / 54	
ODU Sound Power Level	Cooling	Rated	dB(A)	66	69	69	71	
Piping Connections	Liquid			mm (inch)	φ 9.52 (3/8)	φ 9.52 (3/8)	φ 9.52 (3/8)	φ 9.52 (3/8)
	Gas			mm (inch)	φ 15.88 (5/8)	φ 15.88 (5/8)	φ 15.88 (5/8)	φ 15.88 (5/8)
	Connections Method			-	Flared	Flared	Flared	Flared
Operation Range (Outdoor)	Cooling	Min - Max	°C	-20 - 52	-20 - 52	-20 - 52	-20 - 52	
	Heating	Min - Max	°C	-25 - 18	-25 - 18	-25 - 18	-25 - 18	
INDOOR				UV36F.N20	UV42F.N20	UV48F.N20	UV60F.N20	
Power Supply			Ø, V, Hz	1, 220-240, 50	1, 220-240, 50	1, 220-240, 50	1, 220-240, 50	
Power Input (IDU)	H / M / L		W	50 / 35 / 28	50 / 35 / 28	59 / 40 / 28	59 / 40 / 28	
Air Flow Rate	H / M / L		m <sup>3</sup> /min	28 / 24 / 20	28 / 24 / 20	30 / 25 / 20	30 / 25 / 20	
Dimensions	Body	W x H x D	mm	1,600 x 235 x 690	1,600 x 235 x 690	1,600 x 235 x 690	1,600 x 235 x 690	
Weight	Body			kg	36.7	36.7	36.7	
Sound Pressure Level	Cooling	H / M / L	dB(A)	46 / 43 / 40	46 / 43 / 40	48 / 44 / 40	48 / 44 / 40	
Sound Power Level	Cooling	Max.	dB(A)	62	62	63	63	
Piping Connections	Drain(Natural Drainage)	O.D. / I.D.	mm	φ 25.0 / 20.5	φ 25.0 / 20.5	φ 25.0 / 20.5	φ 25.0 / 20.5	
	Drain(Using Drain Pump)	O.D. / I.D.	mm	φ 32.0 / 26.0	φ 32.0 / 26.0	φ 32.0 / 26.0	φ 32.0 / 26.0	
OUTDOOR				UUD3.U30				
Power Supply			Ø, V, Hz	3, 380-415, 50				
Circuit Breaker	Min		A	20				
Power Supply Cable (included Earth)			No x mm <sup>3</sup>	5C x 2.5				
Dimensions	Net	W x H x D	mm	950 x 1,380 x 330				
Weight	Net			kg	85			
Compressor	Type			Inverter Scroll				
	Type			R32				
Refrigerant	GWP (Global Warming Potential)			675				
	Precharged Amount			3.0				
	t-CO <sub>2</sub> eq.			2.025				
	Additional Charge (After 7.5m)			40				
Fan	Air Flow Rate	Rated	m <sup>3</sup> /min x No.	55 x 2				
Total Piping Length	Min / Max		m	5 / 85				
Piping Elevation	IDU - ODU	Max	m	30				

Note :

- Due to our policy of innovation some specifications may be changed without notification.
- Performances are based on the following conditions (It is accordance with EN14511)
  - Cooling : Indoor Ambient Temp. 27°CDB / 19°CWB, Outdoor Ambient Temp. 35°CDB / 24°CWB
  - Heating : Indoor Ambient Temp. 20°CDB / 15°CWB, Outdoor Ambient Temp. 7°CDB / 6°CWB
  - Interconnected Pipe is standard length and difference of Elevation (Outdoor - Indoor Unit) is 0m.
- Sound Level Values are measured at Noise Measuring chamber accordance with standard. Therefore, these values depend on the ambient conditions and values are normally higher in actual operation
- This product contains fluorinated greenhouse gases (R32)

# CEILING SUSPENDED UNIT



## COMPACT INVERTER (R32)

UV18F / UV24F / UV30F / UV36F



LG participates in the ECP programme for EUROVENT AC program.  
Check ongoing validity of certification  
: [www.eurovent-certification.com](http://www.eurovent-certification.com)

UUA1.U10

UUB1.U20

UUC1.U40



COMBINATION				18	24	30	36
Capacity	Cooling	Min - Rated - Max	kW	1.8 / 5.0 / 5.5	2.7 / 6.8 / 7.5	3.0 / 7.5 / 8.3	3.8 / 9.5 / 10.5
	Heating	Min - Rated - Max	kW	2.2 / 5.3 / 5.8	2.9 / 7.3 / 8.4	3.2 / 8.0 / 8.8	4.1 / 10.3 / 11.5
Power Input (Set)	Cooling	Min - Rated - Max	kW	0.32 / 1.62 / 1.93	0.40 / 2.06 / 2.47	0.50 / 2.42 / 2.90	0.70 / 3.28 / 3.87
	Heating	Min - Rated - Max	kW	0.30 / 1.44 / 1.86	0.40 / 2.23 / 2.90	0.50 / 2.48 / 3.22	0.60 / 2.78 / 3.45
Running Current	Cooling	Rated	A	7.2	9.0	10.6	14.6
	Heating	Rated	A	6.4	9.7	10.8	12.3
EER / COP			kWh/kWh	3.10 / 3.70	3.30 / 3.28	3.10 / 3.23	2.90 / 3.70
SEER / SCOP			kWh/kWh	6.6 / 4.6	6.6 / 4.2	6.6 / 4.3	6.1 / 4.2
Pdesign	Cooling @ 35°C		kW	5	6.8	7.5	9.5
	Heating @ -10°C		kW	2.9	4.3	4.4	5.5
Seasonal Energy Label	Cooling / Heating		-	A++ / A++	A++ / A+	A++ / A+	A++ / A+
Annual Energy Consumption	Cooling / Heating		kWh	265 / 883	361 / 1,433	398 / 1,433	545 / 1,833
Dehumidification Rate			l/h	1.7	2.4	2.8	3.6
ODU Sound Pressure Level	Cooling / Heating	Rated	dB(A)	49 / 52	48 / 53	50 / 54	54 / 56
ODU Sound Power Level	Cooling	Rated	dB(A)	65	65	67	70
Piping Connections	Liquid		mm (inch)	φ 6.35 (1/4)	φ 9.52 (3/8)	φ 9.52 (3/8)	φ 9.52 (3/8)
	Gas		mm (inch)	φ 12.7 (1/2)	φ 15.88 (5/8)	φ 15.88 (5/8)	φ 15.88 (5/8)
Connections Method			-	Flared	Flared	Flared	Flared
Operation Range (Outdoor)	Cooling	Min - Max	°C	-10 - 50	-10 - 48	-10 - 48	-20 - 50
	Heating	Min - Max	°C	-10 - 18	-15 - 18	-15 - 18	-15 - 18
INDOOR				UV18F.N10	UV24F.N10	UV30F.N10	UV36F.N20
Power Supply			Ø, V, Hz	1, 220-240, 50	1, 220-240, 50	1, 220-240, 50	1, 220-240, 50
Power Input (IDU)		H / M / L	W	17 / 15 / 13	33 / 26 / 19	47 / 40 / 33	50 / 35 / 28
Air Flow Rate		H / M / L	m <sup>3</sup> / min	13 / 12 / 11	16 / 15 / 14	19 / 17.5 / 16	28 / 24 / 20
Dimensions	Body	W x H x D	mm	1,200 x 235 x 690	1,200 x 235 x 690	1,200 x 235 x 690	1,600 x 235 x 690
Weight	Body		kg	27.3	28	28	36.7
Sound Pressure Level	Cooling	H / M / L	dB(A)	42 / 40 / 39	46 / 45 / 43	46 / 44 / 43	46 / 43 / 40
Sound Power Level	Cooling	Max.	dB(A)	55	61	62	62
Piping Connections	Drain(Natural Drainage)	O.D. / I.D.	mm	φ 25.0 / 20.5	φ 25.0 / 20.5	φ 25.0 / 20.5	φ 25.0 / 20.5
	Drain(Using Drain Pump)	O.D. / I.D.	mm	φ 32.0 / 26.0	φ 32.0 / 26.0	φ 32.0 / 26.0	φ 32.0 / 26.0
OUTDOOR				UUA1.U10	UUB1.U20	UUC1.U40	
Power Supply			Ø, V, Hz	1, 220-240, 50	1, 220-240, 50	1, 220-240, 50	
Circuit Breaker		Min	A	15	20	25	
Power Supply Cable (included Earth)			No x mm <sup>3</sup>	3C x 2.5	3C x 2.5	3C x 2.5	
Dimensions	Net	W x H x D	mm	770 x 545 x 288	870 x 650 x 330	950 x 834 x 330	
Weight	Net		kg	33.3	44.5	57.7	
Compressor	Type		-	Twin Rotary	Twin Rotary	Twin Rotary	
	Type		-	R32	R32	R32	
Refrigerant	GWP (Global Warming Potential)		-	675	675	675	
	Precharged Amount		kg	1.0	1.2	1.9	
	t-CO <sub>2</sub> eq.		-	0.675	0.81	1.283	
Additional Charge (After 7.5m)			g/m	20	40	40	
Fan	Air Flow Rate	Rated	m <sup>3</sup> /min x No.	28 x 1	50 x 1	58 x 1	
Total Piping Length		Min / Max	m	5 / 30	5 / 35	5 / 50	
Piping Elevation	IDU - ODU	Max	m	30	30	30	

Note :

- Due to our policy of innovation some specifications may be changed without notification.
- Performances are based on the following conditions (It is accordance with EN14511)
  - Cooling : Indoor Ambient Temp. 27°CDB / 19°CWB, Outdoor Ambient Temp. 35°CDB / 24°CWB
  - Heating : Indoor Ambient Temp. 20°CDB / 15°CWB, Outdoor Ambient Temp. 7°CDB / 6°CWB
  - Interconnected Pipe is standard length and difference of Elevation (Outdoor - Indoor Unit) is 0m.
- Sound Level Values are measured at Noise Measuring chamber accordance with standard. Therefore, these values depend on the ambient conditions and values are normally higher in actual operation
- This product contains fluorinated greenhouse gases (R32)

# CONSOLE



# CONSOLE

## Optimised Air Flow for Cooling & Heating

During cooling operation, the vane adjusts upwards to direct air flow toward the ceiling. During heating operation, the van directs the air flow toward the floor to balance out the room temperature. A wireless controller is included with the indoor console unit.

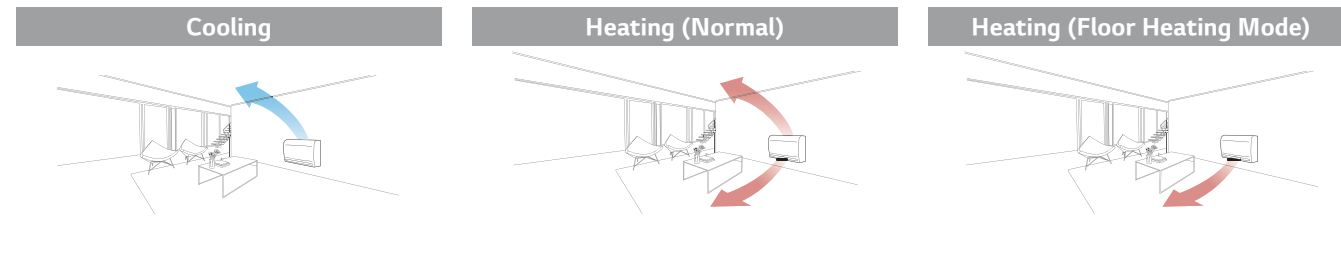

## Quick Floor Heating

Console air conditioners portray high speed and powerful performance. Using the floor heating mode, console air conditioners provide floor heating at a faster pace in order to reach desired temperature more quickly.

	Company A	Electric Heater	LG	LG Floor Heating Mode
	Vertical			
	Horizontal			
<b>Lead Time for Heating (13°C - 21°C)</b>	12 minutes 30 seconds	50 minutes	<b>9 minutes 30 seconds</b>	<b>8 minutes 40 seconds</b>

(Test Condition :Target Temp 23°C, Indoor Room : 13°C~, Outdoor Room : 7°C)

## 5-Step Vane Control

There are 5 different stages to control air flow direction.

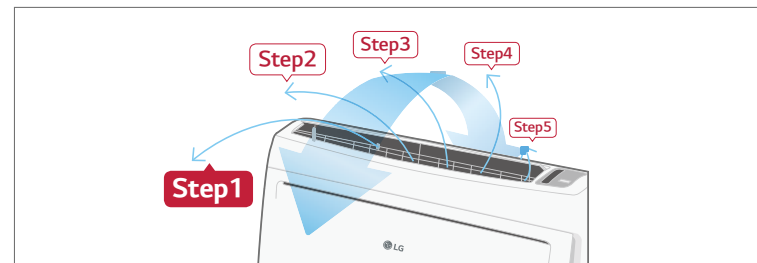

## Easy Installation and Service

### 6 Different Ways to Install Piping

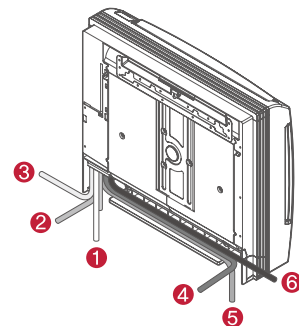

### Easy Slide-type PCB

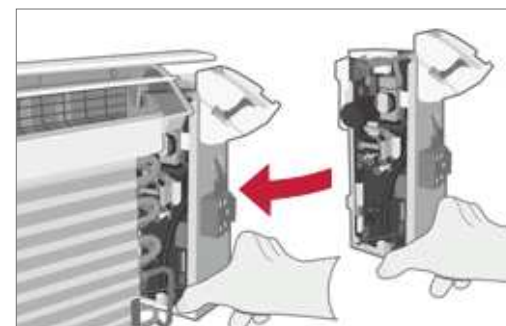

# CONSOLE



## STANDARD INVERTER (R32)

UQ09F  
UQ12F  
UQ18F

UUA1.ULO UUB1.U20



LG participates in the ECP programme for EUROVENT AC program. Check ongoing validity of certification : www.eurovent-certification.com



COMBINATION				9	12	18
Capacity	Cooling	Min - Rated - Max	kW	1.5 / 2.6 / 3.4	1.5 / 3.5 / 4.0	2.0 / 5.0 / 5.8
	Heating	Min - Rated - Max	kW	1.6 / 3.1 / 3.9	1.6 / 4.0 / 4.3	2.0 / 4.9 / 5.4
Power Input (Set)	Cooling	Min - Rated - Max	kW	0.30 / 0.65 / 0.91	0.30 / 1.00 / 1.46	0.40 / 1.75 / 2.45
	Heating	Min - Rated - Max	kW	0.30 / 0.74 / 1.08	0.30 / 1.05 / 1.58	0.30 / 1.56 / 2.11
Running Current	Cooling	Rated	A	2.9	4.4	8.3
	Heating	Rated	A	3.3	4.7	8.0
EER / COP			kWh/kWh	4.00 / 4.20	3.50 / 3.80	2.85 / 3.14
SEER / SCOP			kWh/kWh	6.5 / 4.0	6.4 / 4.0	5.8 / 3.8
Pdesign	Cooling @ 35°C		kW	2.6	3.5	5
	Heating @ -10°C		kW	2.8	3	3.8
Seasonal Energy Label	Cooling / Heating			A++ / A+	A++ / A+	A+ / A
Annual Energy Consumption	Cooling / Heating		kWh	140 / 980	191 / 1,050	302 / 1,396
Dehumidification Rate			l/h	0.7	1.3	2.4
ODU Sound Pressure Level	Cooling / Heating	Rated	dB(A)	49 / 52	49 / 52	47 / 52
ODU Sound Power Level	Cooling	Rated	dB(A)	65	65	63
Piping Connections	Liquid		mm (inch)	φ 6.35 (1/4)	φ 6.35 (1/4)	φ 6.35 (1/4)
	Gas		mm (inch)	φ 9.52 (3/8)	φ 9.52 (3/8)	φ 12.7 (1/2)
	Connections Method			Flared	Flared	Flared
Operation Range (Outdoor)	Cooling	Min - Max	°C	-15 - 50	-15 - 50	-15 - 50
	Heating	Min - Max	°C	-20 - 18	-20 - 18	-20 - 18
INDOOR				UQ09F.NAO	UQ12F.NAO	UQ18F.NAO
Power Supply			∅, V, Hz	1, 220-240, 50	1, 220-240, 50	1, 220-240, 50
Power Input (IDU)		H / M / L	W	37 / 30 / 25	37 / 30 / 25	44 / 39 / 35
Air Flow Rate		H / M / L	m³/min	8.5 / 6.7 / 5.0	8.5 / 6.7 / 5.0	10.1 / 8.6 / 7.2
Dimensions	Body	W x H x D	mm	700 x 600 x 210	700 x 600 x 210	700 x 600 x 210
Weight	Body		kg	16.3	16.3	16.3
Sound Pressure Level	Cooling	H / M / L	dB(A)	38 / 32 / 27	38 / 32 / 27	44 / 39 / 35
Sound Power Level	Cooling	Max.	dB(A)	59	59	60
Piping Connections	Drain	O.D. / I.D.	mm	φ 16.7 / 12.2	φ 16.7 / 12.2	φ 16.7 / 12.2
OUTDOOR				UUA1.ULO	UUB1.U20	
Power Supply			∅, V, Hz	1, 220-240, 50	1, 220-240, 50	
Circuit Breaker		Min	A	15	20	
Power Supply Cable (included Earth)			No x mm²	3C x 2.5	3C x 2.5	
Dimensions	Net	W x H x D	mm	770 x 545 x 288	870 x 650 x 330	
Weight	Net		kg	33.3	44.5	
Compressor	Type			Twin Rotary	Twin Rotary	
				R32	R32	
Refrigerant	GWP (Global Warming Potential)			675	675	
	Precharged Amount		kg	1.0	1.2	
	t-CO <sub>2</sub> eq.			0.675	0.81	
	Additional Charge (After 7.5m)		g/m	20	20	
Fan	Air Flow Rate	Rated	m³/min x No.	28 x 1	50 x 1	
Total Piping Length		Min / Max	m	5 / 30	5 / 30	
Piping Elevation	IDU - ODU	Max	m	30	30	

Note :

- Due to our policy of innovation some specifications may be changed without notification.
- Performances are based on the following conditions (It is accordance with EN14511)
  - Cooling : Indoor Ambient Temp. 27°CDB / 19°CWB, Outdoor Ambient Temp. 35°CDB / 24°CWB
  - Heating : Indoor Ambient Temp. 20°CDB / 15°CWB, Outdoor Ambient Temp. 7°CDB / 6°CWB
  - Interconnected Pipe is standard length and difference of Elevation (Outdoor - Indoor Unit) is 0m.
- Sound Level Values are measured at Noise Measuring chamber accordance with standard. Therefore, these values depend on the ambient conditions and values are normally higher in actual operation
- This product contains fluorinated greenhouse gases (R32)

# FLOOR STANDING UNIT



SINGLE SPLIT KEY FEATURES

## FLOOR STANDING UNIT

### Stylish Design

The new LG floor standing air conditioner which is Red Dot design award winner 2013, is ideal for modern interiors in your home or office.



reddot design award  
winner 2013

COMMERCIAL

SINGLE SPLIT

### Quick Response

Offering powerful cooling, the commercial air conditioning system can reach a set temperature in a shorter period of time. Meanwhile, the Power Heating function provides the optimal airflow angle, guaranteeing a faster heating performance.

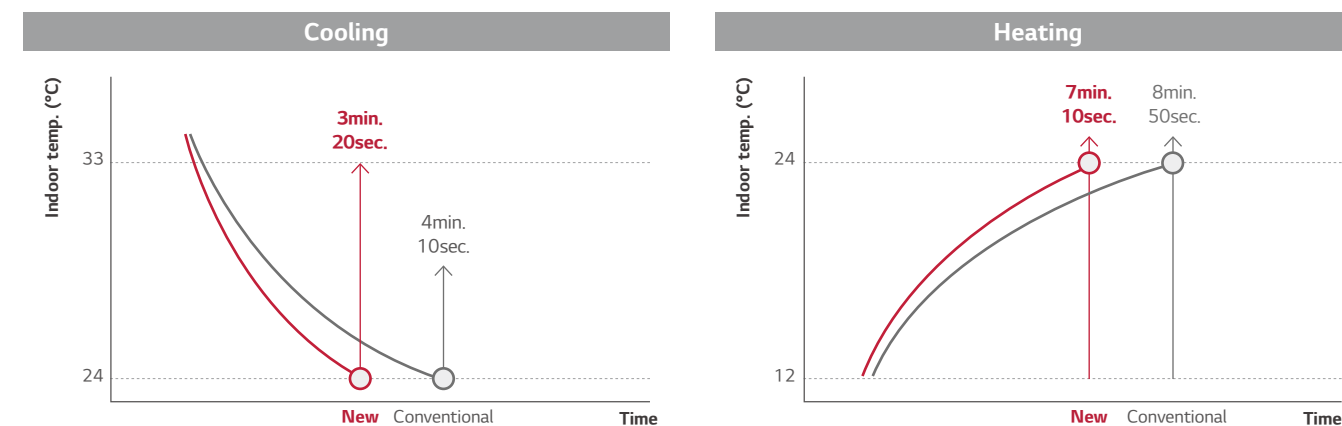

### Powerful Air Flow

The new LG floor standing air conditioner is efficient for using in large areas due to its powerful cooling and heating operation. The powerful air speed and volume means the air flow can reach up to 20m away from the air conditioner.

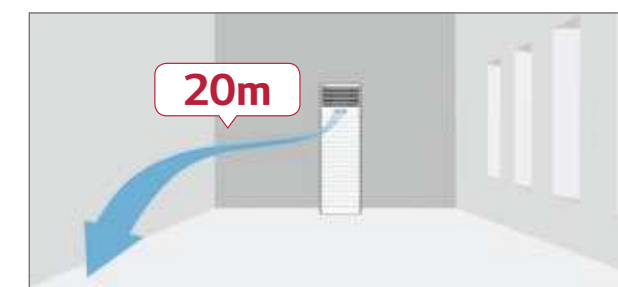

# FLOOR STANDING UNIT



## STANDARD INVERTER (R410A)

### UP48



LG participates in the ECP programme for EUROVENT AC program. Check ongoing validity of certification : [www.eurovent-certification.com](http://www.eurovent-certification.com)

### UU48W



### UU49W



INDOOR				UP48.NT2	UP49.NT2
Capacity	Cooling	Min / Nom / Max	kW	6.0 / 13.4 / 15.2	6.0 / 13.4 / 15.2
	Heating	Min / Nom / Max	kW	6.0 / 15.5 / 17.1	6.0 / 15.5 / 17.1
Low Temperature Capacity	Heating -7°C	Max	kW	16.0	16.0
Power Input (Set)	Cooling	Nom	kW	4.2	4.2
	Heating	Nom	kW	4.5	4.5
Power Input (Indoor)		Nom	W	200	200
Running Current	Cooling / Heating	Nom	A	18.1 / 19.5	5.76 / 6.20
Power Supply			Ø, V, Hz	1, 220-240, 50	1, 220-240, 50
EER				3.21	3.21
COP				3.41	3.41
SEER				5.05	5.05
SCOP				3.51	3.51
Pdesign (@ -10°C)			kW	11.5	11.5
Seasonal Energy Label	Cooling / Heating			-	-
Annual Energy Consumption	Cooling / Heating		kWh	-	-
Piping Connection	Liquid		mm (inch)	Ø9.52 (3/8)	Ø9.52 (3/8)
	Gas		mm (inch)	Ø15.88 (5/8)	Ø15.88 (5/8)
	Drain	O.D. / I.D.	mm	32 / 25	32 / 25
Air Flow Rate		High / Medium / Low	m³/min	31 / 27 / 23	31 / 27 / 23
Sound Pressure	Cooling	High / Medium / Low	dB(A)	52 / 49 / 45	52 / 49 / 45
Sound Power	Cooling	Max	dB(A)	65	59
Dehumidification Rate			l/h	5.0	5.0
Dimensions	Body	W x H x D	mm	590 x 1,840 x 460	590 x 1,840 x 460
Net Weight	Body		kg	50.0	50.0
OUTDOOR				UU48W.U32	UU49W.U32
Compressor	Type			Twin Rotary	Twin Rotary
Airflow Rate		Nom	m³/min	110	110
Sound Pressure	Cooling	Nom	dB(A)	52	52
	Heating	Nom	dB(A)	54	54
Sound Power	Cooling	Max	dB(A)	72	68
Dimensions	W x H x D		mm	950 x 1,380 x 330	950 x 1,380 x 330
Net Weight			kg	92.0	96.0
Refrigerant	Type			R410A	R410A
	Charge		g	3,400	3,400
	Additional Charge		g/m	40	40
	GWP			2087.5	2087.5
	TCO2eq			7.1	7.1
Operation Range (Outdoor)	Cooling	Min / Max	°C DB	-15 / 48	-15 / 48
	Heating	Min / Max	°C WB	-18 / 18	-18 / 18
Power Supply			Ø, V, Hz	1, 220-240, 50	3, 380-415, 50
Power Supply Cable			No. x mm²	3C x 5.0	5C x 5.0
Transmission Cable			No. x mm²	4C x 0.75	4C x 0.75
Circuit Breaker			A	40	20
Piping Length Total		Min / Max	m	5 / 75	5 / 75
Piping Elevation Difference	IDU - ODU	Max	m	30	30
Piping Connection	Liquid		mm (inch)	Ø9.52 (3/8)	Ø9.52 (3/8)
	Gas		mm (inch)	Ø15.88 (5/8)	Ø15.88 (5/8)

Note :

- Due to our policy of innovation some specifications may be changed without notification.
- Performances are based on the following conditions (It is accordance with EN14511)
  - Cooling : Indoor Ambient Temp. 27°CDB / 19°CWB, Outdoor Ambient Temp. 35°CDB / 24°CWB
  - Heating : Indoor Ambient Temp. 20°CDB / 15°CWB, Outdoor Ambient Temp. 7°CDB / 6°CWB
  - Interconnected Pipe is standard length and difference of Elevation (Outdoor - Indoor Unit) is 0m.
- Sound Level Values are measured at Noise Measuring chamber accordance with standard. Therefore, these values depend on the ambient conditions and values are normally higher in actual operation
- This product contains fluorinated greenhouse gases (R410A)

# WALL MOUNTED UNIT



# WALL MOUNTED UNIT

## Wide Operational Range

Ideal and comprehensive solution for server rooms, machine rooms and kitchens.

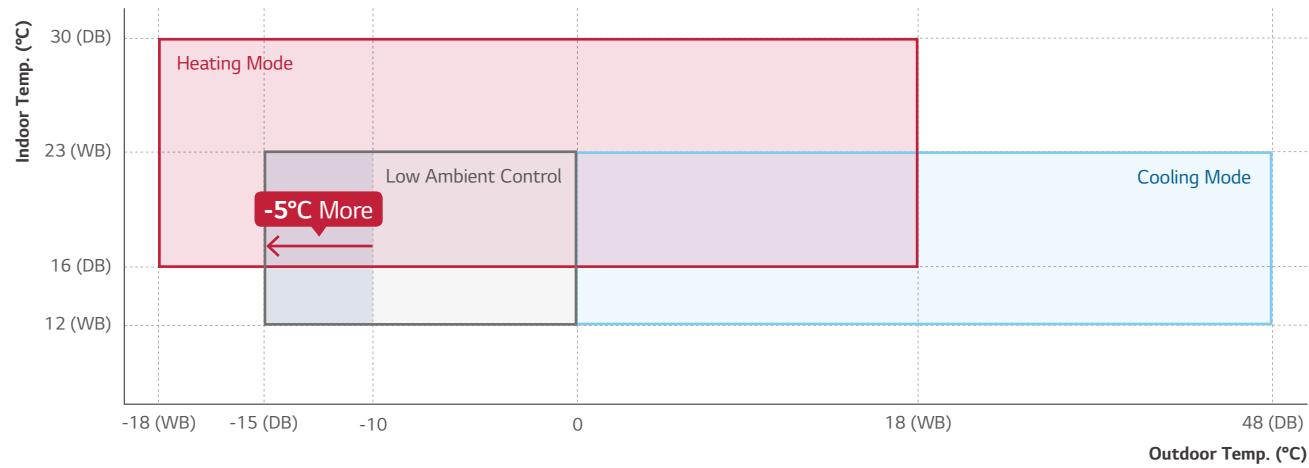

## Easy Installation

### Detachable Bottom Cover

The bottom cover is detachable when needed, making installation easier. Disassembly or additional support of the unit is unnecessary. Installation can be completed by one individual with LG's patented support tool.

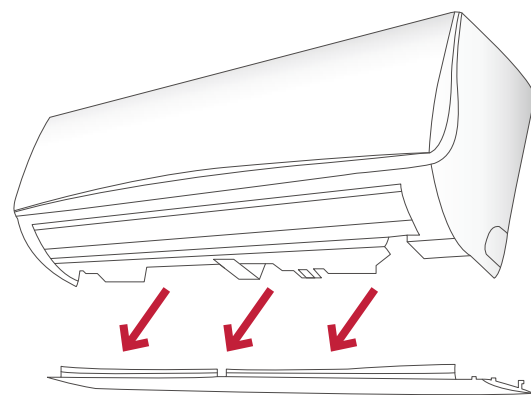

### Installation Support Clip

A support clip creates adequate space between the wall and the unit for easier installation.

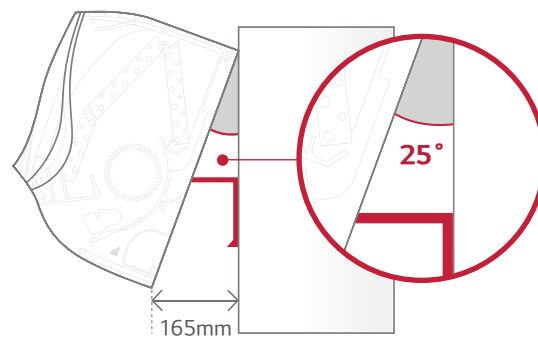

# WALL MOUNTED UNIT

## High Energy Efficiency

New wall mounted units provide good seasonal energy efficiency connected with Standard Inverter outdoor units.

	8.0kW	9.5kW
SEER	7.0 (A++)	6.1 (A++)
SCOP	4.3 (A+)	3.85 (A+)

## Powerful Cooling & Heating

### 20m Windblast

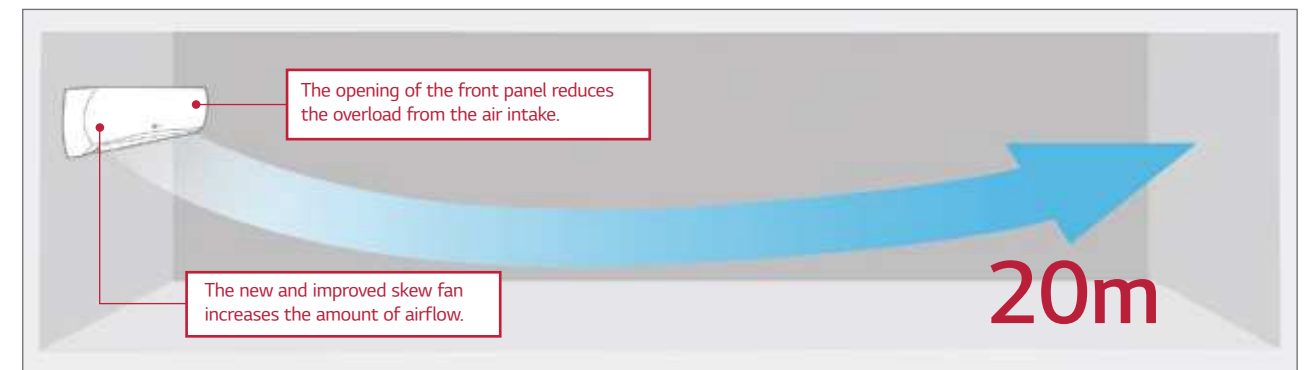

### Optimised Airflow

Direction of horizontal vane can be adjusted from step 1 to step 6 with full auto swing. This function can cool and heat specific areas much faster.

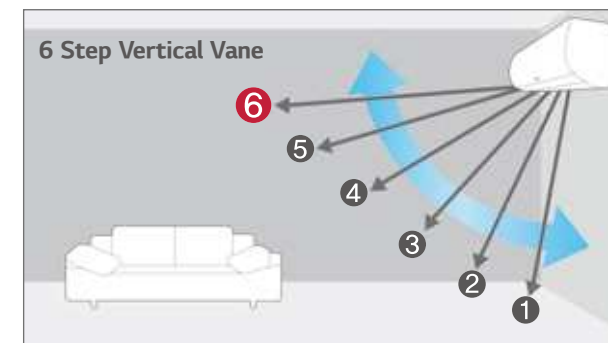

### Quick Cooling & Heating

Jet cooling and heating disperses air evenly at high speed to secure an optimally cooled or heated room in just 3 minutes.





## WALL MOUNTED UNIT



## STANDARD INVERTER (R32)

US30F / US36F



LG participates in the ECP programme for EUROVENT AC program.  
Check ongoing validity of certification  
: www.eurovent-certification.com

UUC1.U40



UUD1.U30



UUD3.U30



COMBINATION				30	36	36
Capacity	Cooling	Min - Rated - Max	kW	3.2 / 8.0 / 9.0	3.8 / 9.5 / 12.5	3.8 / 9.5 / 12.5
	Heating	Min - Rated - Max	kW	3.6 / 9.0 / 10.0	4.3 / 10.8 / 13.4	4.3 / 10.8 / 13.4
Power Input (Set)	Cooling	Min - Rated - Max	kW	0.50 / 2.28 / 3.17	0.30 / 2.57 / 3.91	0.30 / 2.57 / 3.91
	Heating	Min - Rated - Max	kW	0.50 / 2.5 / 3.20	0.50 / 2.77 / 3.77	0.50 / 2.77 / 3.77
Running Current	Cooling	Rated	A	10.1	11.4	4.1
	Heating	Rated	A	11.1	12.2	4.4
EER / COP			kWh/kWh	3.51 / 3.60	3.70 / 3.90	3.70 / 3.90
SEER / SCOP			kWh/kWh	7.0 / 4.3	6.10 / 3.85	6.10 / 3.85
Pdesign	Cooling @ 35°C			kW	8	9.5
	Heating @ -10°C			kW	5.4	8.7
Seasonal Energy Label	Cooling / Heating		-	A++ / A+	A++ / A	A++ / A
Annual Energy Consumption	Cooling / Heating		kWh	400 / 1,758	545 / 3,164	545 / 3,164
Dehumidification Rate			l/h	2.9	3.8	3.8
ODU Sound Pressure Level	Cooling / Heating	Rated	dB(A)	50 / 52	50 / 50	50 / 50
	Cooling	Rated	dB(A)	68	66	66
Piping Connections	Liquid			mm (inch)	φ 9.52 (3/8)	φ 9.52 (3/8)
	Gas			mm (inch)	φ 15.88 (5/8)	φ 15.88 (5/8)
Connections Method				-	Flared	Flared
Operation Range (Outdoor)	Cooling	Min - Max	°C	-20 - 50	-20 - 52	-20 - 52
	Heating	Min - Max	°C	-20 - 18	-25 - 18	-25 - 18

INDOOR			US30F.NR0	US36F.NR0	US36F.NR0
Power Supply			∅, V, Hz	1, 220-240, 50	1, 220-240, 50
Power Input (IDU)	H / M / L		W	47 / 42 / 36	65 / 47 / 42
Air Flow Rate	H / M / L		m³/min	21 / 17 / 13	25 / 21 / 17
Dimensions	Body W x H x D		mm	1,200 x 360 x 265	1,200 x 360 x 265
Weight	Body		kg	18.3	18.3
Sound Pressure Level	Cooling	H / M / L	dB(A)	46.0 / 42.0 / 38.0	51.0 / 46.0 / 42.0
Sound Power Level	Cooling	Max.	dB(A)	62	65
Piping Connections	Drain	O.D. / I.D.	mm	φ 21.5 / 16.0	φ 21.5 / 16.0

OUTDOOR			UUC1.U40	UUD1.U30	UUD3.U30
Power Supply			∅, V, Hz	1, 220-240, 50	3, 380-415, 50
Circuit Breaker	Min		A	25	40
Power Supply Cable (included Earth)			No x mm³	3C x 2.5	3C x 6.0
Dimensions	Net W x H x D		mm	950 x 834 x 330	950 x 1,380 x 330
Weight	Net		kg	57.7	85
Compressor	Type			-	Twin Rotary
	Type			-	R32
	GWP (Global Warming Potential)			-	675
	Precharged Amount			kg	1.9
Refrigerant	t-CO <sub>2</sub> eq.			-	1.283
	Additional Charge (After 7.5m)			g/m	40
	Air Flow Rate	Rated	m³/min x No.	58 x 1	55 x 2
Total Piping Length	Min / Max		m	5 / 50	5 / 85
Piping Elevation	IDU - ODU	Max	m	30	30

Note :

- Due to our policy of innovation some specifications may be changed without notification.
- Performances are based on the following conditions (It is accordance with EN14511)
  - Cooling : Indoor Ambient Temp. 27°CDB / 19°CWB, Outdoor Ambient Temp. 35°CDB / 24°CWB
  - Heating : Indoor Ambient Temp. 20°CDB / 15°CWB, Outdoor Ambient Temp. 7°CDB / 6°CWB
  - Interconnected Pipe is standard length and difference of Elevation (Outdoor - Indoor Unit) is 0m.
- Sound Level Values are measured at Noise Measuring chamber accordance with standard. Therefore, these values depend on the ambient conditions and values are normally higher in actual operation
- This product contains fluorinated greenhouse gases (R32)

## WALL MOUNTED UNIT



## COMPACT INVERTER (R32)

US30F / US36F



LG participates in the ECP programme for EUROVENT AC program.  
Check ongoing validity of certification  
: www.eurovent-certification.com

UUB1.U20



UUC1.U40



COMBINATION				30	36
Capacity	Cooling	Min - Rated - Max	kW	3.0 / 7.5 / 8.3	3.8 / 9.5 / 10.6
	Heating	Min - Rated - Max	kW	3.1 / 7.7 / 8.5	4.3 / 10.8 / 11.5
Power Input (Set)	Cooling	Min - Rated - Max	kW	0.50 / 2.31 / 2.77	0.60 / 3.06 / 3.67
	Heating	Min - Rated - Max	kW	0.40 / 2.14 / 2.78	0.60 / 3.0 / 3.72
Running Current	Cooling	Rated	A	10.1	13.6
	Heating	Rated	A	9.3	13.3
EER / COP			kWh/kWh	3.25 / 3.60	3.10 / 3.60
SEER / SCOP			kWh/kWh	6.8 / 4.1	6.4 / 4.1
Pdesign	Cooling @ 35°C			kW	7.5
	Heating @ -10°C			kW	4.3
Seasonal Energy Label	Cooling / Heating		-	A++ / A+	A++ / A+
Annual Energy Consumption	Cooling / Heating		kWh	386 / 1,468	520 / 1,980
Dehumidification Rate			l/h	3.0	3.5
ODU Sound Pressure Level	Cooling / Heating	Rated	dB(A)	50 / 54	54 / 56
	Cooling	Rated	dB(A)	67	70
Piping Connections	Liquid			mm (inch)	φ 9.52 (3/8)
	Gas			mm (inch)	φ 15.88 (5/8)
Connections Method				-	Flared
Operation Range (Outdoor)	Cooling	Min - Max	°C	-10 - 48	-20 - 50
	Heating	Min - Max	°C	-15 - 18	-15 - 18

INDOOR			US30F.NR0	US36F.NR0
Power Supply			∅, V, Hz	1, 220-240, 50
Power Input (IDU)	H / M / L		W	47 / 42 / 36
Air Flow Rate	H / M / L		m³/min	21 / 17 / 13
Dimensions	Body W x H x D		mm	1,200 x 360 x 265
Weight	Body		kg	18.3
Sound Pressure Level	Cooling	H / M / L	dB(A)	46.0 / 42.0 / 38.0
Sound Power Level	Cooling	Max.	dB(A)	62
Piping Connections	Drain	O.D. / I.D.	mm	φ 21.5 / 16.0

OUTDOOR			UUB1.U20	UUC1.U40
Power Supply			∅, V, Hz	1, 220-240, 50
Circuit Breaker	Min		A	20
Power Supply Cable (included Earth)			No x mm³	3C x 2.5
Dimensions	Net W x H x D		mm	870 x 650 x 330
Weight	Net		kg	44.5
Compressor	Type			-
	Type			-
	GWP (Global Warming Potential)			-
	Precharged Amount			kg
Refrigerant	t-CO <sub>2</sub> eq.			-
	Additional Charge (After 7.5m)			g/m
	Air Flow Rate	Rated	m³/min x No.	50 x 1
Total Piping Length	Min / Max		m	5 / 35
Piping Elevation	IDU - ODU	Max	m	30

Note :

- Due to our policy of innovation some specifications may be changed without notification.
- Performances are based on the following conditions (It is accordance with EN14511)
  - Cooling : Indoor Ambient Temp. 27°CDB / 19°CWB, Outdoor Ambient Temp. 35°CDB / 24°CWB
  - Heating : Indoor Ambient Temp. 20°CDB / 15°CWB, Outdoor Ambient Temp. 7°CDB / 6°CWB
  - Interconnected Pipe is standard length and difference of Elevation (Outdoor - Indoor Unit) is 0m.
- Sound Level Values are measured at Noise Measuring chamber accordance with standard. Therefore, these values depend on the ambient conditions and values are normally higher in actual operation
- This product contains fluorinated greenhouse gases (R32)

# AHU SOLUTION



## AHU COMBINATION

### Air Handling Applications

Economically feasible solution for pair application with air handling units.

#### Return/Room Air Temperature Control

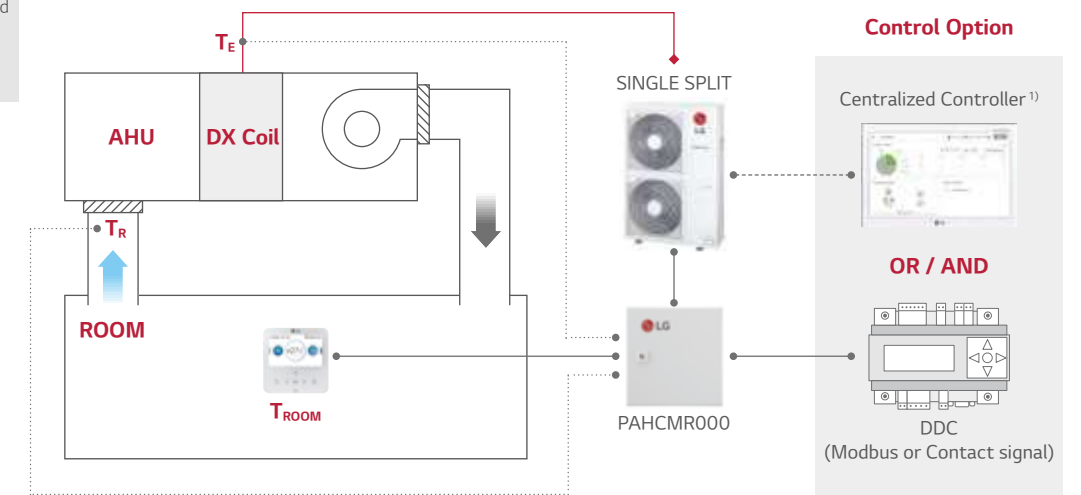
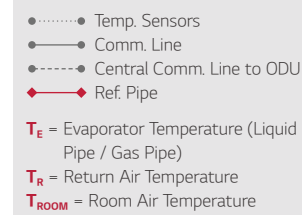

#### Discharge Air Temperature Control

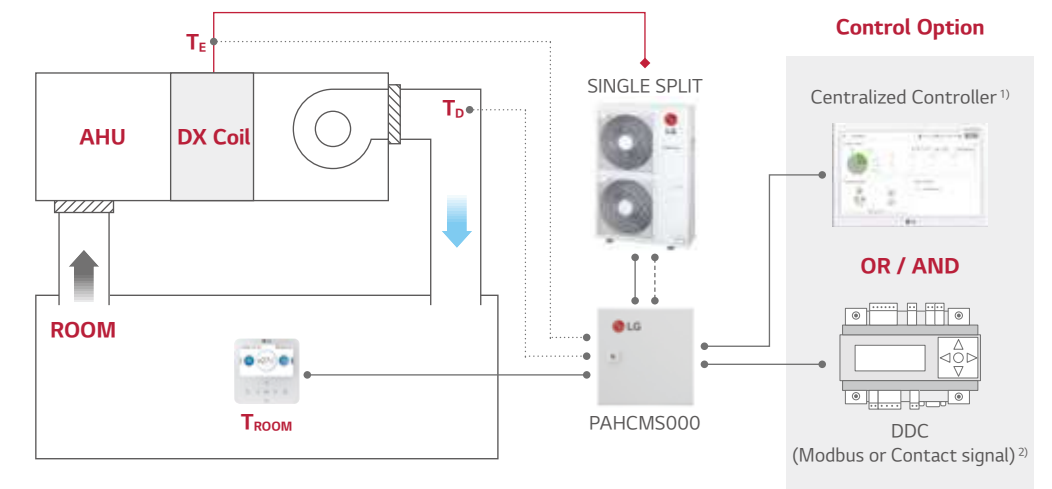
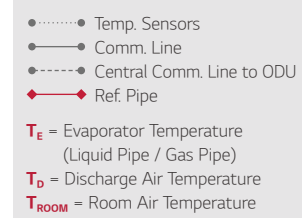

1) PI485(PMNF14A1) is required for using centralized controller  
 2) In case of applying DDC with contact signal, discharge air temperature should be measured and controlled by DDC  
 3) For more detail, please refer to the PDB of AHU Communication Kit

# AHU COMBINATION

## COMMUNICATION KIT

PAHCMR000  
PAHCMS000



## Specifications

MODEL	COMBINATION		DESCRIPTION	DIMENSIONS (MM)		
	OUTDOOR UNIT	CENTRALIZED CONTROLLER		W	H	D
PAHCMR000	Single Split	•	Return / Room air temperature control by DDC or LG individual / centralized controller	300	300	155
PAHCMS000	Single Split	•	Discharge air temperature control by DDC or LG individual / centralized controller	380	300	155

## Function list for Communication kit

FUNCTION LIST*	PAHCMR000	PAHCMS000	NOTE
Comm. Kit Operation	On / Off	On / Off	
Operation Mode <sup>1)</sup>	Cooling / Heating	Cooling / Heating	
Return (room) Air Temperature	16-30°C	-	
Control			
Discharge Air Temperature <sup>2)</sup>	-	16-30°C	Available in case of using DDC with Modbus or LG Control system
Fan Speed <sup>3)</sup>	Low / Middle / High	Low / Middle / High	It may not be possible depending on the particular condition
Forced Thermal On / Off	On / Off	-	Available in case of using DDC with contact signal
Capacity Control	-	•	Available in case of using DDC with Modbus or contact signal
Monitor			
Comm. Kit Operation	On / Off	On / Off	
Operation Mode <sup>1)</sup>	Cooling / Heating	Cooling / Heating	Available in case of using DDC with Modbus or LG Control system
Fan Speed	Low / Middle / High	Low / Middle / High	
Error Alarm	•	•	
Compressor On / Off	On / Off	On / Off	Available in case of using DDC with Modbus or LG individual controller PAHCMR000 doesn't provide this in case of using DDC with contact signal

1) Available operation mode can be varied depending on the setting of AHU Communication Kit.

2) This range may differ depending on the type of controller

3) To control and monitor the fan speed, DO ports for the fan speed status have to be connected with the fan unit

\* Some of functions may not be possible depending on the setting of AHU Communication Kit. For more details of condition, please refer to the product data book

## Combination Table

Model Name	R32				R410A	
	UUA1.U10	UUB1.U20	UUC1.U40	UUD1.U30 UUD3.U30	UU70W.U34	UU85W.U74
Capacity Index	9 - 18	18 - 30	24 - 36	36 - 60	70	85
Range	2.5 - 5.0	5.0 - 8.0	6.8 - 10.0	10.0 - 14.6	20.0	25.0
PAHCMR000	X	0	0	0	0	0
PAHCMS000	X	0	0	0	0	0

# ACCESSORIES



# LG WI-FI MODEM

Users can control air conditioners using Android or iOS-enabled smartphones.

PWFMDD200



## Features

- Access LG air conditioner anytime and from anywhere with Wi-Fi equipped device
- LG's exclusive Home Appliances control app(ThinQ) is available
- Simple operation for various functions
  - On/Off
  - Fan Speed
  - Energy Monitoring <sup>1)</sup>
  - Operation Mode
  - Vane Control <sup>2)</sup>
  - Filter Management
  - Current/Set Temperature
  - Reservation (Sleep, Weekly On/Off)
  - Error check



MODEL NAME	PWFMDD200
Size (W x H x D, mm)	48 x 68 x 14
Interfaceable Products	Single Indoor unit <sup>3)</sup>
Connection Type	Indoor unit 1:1
Communication Frequency	2.4 GHz
Wireless Standards	IEEE 802.11b/g/n
Mobile Application	LG Smart ThinQ (Android v4.1(Jellybean) or higher, iPhone iOS 9.0 or higher)
Optional Extension Cable	PWYREW000 (10m extension)

\* Functionality may be different according to each IDU model  
 \* User interface of application shall be revised for its design and contents improvement  
 \* Application is optimized for smartphone use, so it may not be well functioning with tablet devices  
 1) LG Centralized controller and PDI installation is required for this function  
 2) Vane Control may not be possible according to the type of Indoor unit  
 3) For the compatibility with Indoor unit, please contact regional office

## Overview

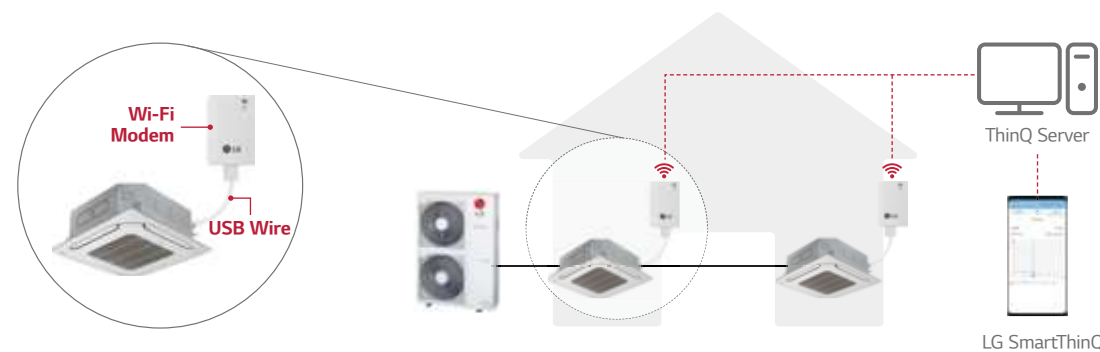

\* Search "LG Smart ThinQ" on Google market or Appstore then download the app.  
 \* Internet service with Wi-Fi connection has to be available

# ACCESSORIES

## Standard Wired Remote Controller



Model Name	PREMTB100 PREMTBB10	PREMTB001 PREMTBB01
Operation Mode	On/Off, Fan Speed Control, Temperature Setting	
Mode Change	Cooling / Heating / Auto / Dehumidification / Fan	
Auto Swing / Vane Control	•	•
Reservation	Simple / Sleep / On, Off / Weekly / Holiday	
Time Display	•	•
Electrical Failure Compensation	•	•
Child Lock	•	•
Operation Status LED	•	•
Indoor Temperature Display	•	•
Wireless Remote Controller Receiver	-	•
Size (W x H x D, mm)	120 x 120 x 16	120 x 121 x 16
Backlight	•	•

\* Refer to each model PDB for applicable models.

## Remote Controller



PQWRHQ0FDB

## PI 485



PMNFP14A1

Power : Single phase AC 220V 50/60Hz  
 Max. no of the indoor units that can be connected: 64 UNITS  
 Model applied : RAC / Multi / Single / Thermo V

\* Refer to each product PDB for applicable models

## Dry Contact



MODEL	PDRYCB000	PDRYCB400	PDRYCB300/320 <sup>1)</sup>	PDRYCB500
Contact Point	1 Control Point	2 Control Point	8 Control Point	Modbus RTU
Power Input	AC 220V from outside power source	DC 5V & 12V from indoor unit PCB	DC 5V & 12V from indoor unit PCB	DC 5V & 12 V from indoor unit PDB
Voltage / Non Voltage Input		•	•	
On / Off Control	•	•	•	•
Lock / Unlock	•	•	•	
Fan Speed Setting				•
Thermo Off		•	•	
Energy Saving		•		
Temperature Setting		•	•	•
Error Monitoring	•	•	•	•
Operation Monitoring	•	•	•	•

\* Refer to each product PDB for applicable models  
 1) Available April 2020. Can use a universal input port with PDRYCB320 model.

# CEILING CASSETTE

H-INVERTER (R32)

## UT09FH.NQ0 / UT12FH.NQ0

(Unit : mm)

Part Name
1 Gas Pipe Connection
2 Liquid Pipe Connection
3 Drain Pipe Connection
4 Power and Communication cable routing hole
5 Wired remote controller wire routing hole
6 Air Intake
7 Air Outlet
8 Decoration Panel (Accessory)
9 Decoration Corner Cover
10 Decoration Coner Display Cover
11 Flexible Drain Hose
12 Fresh air Intake Hole

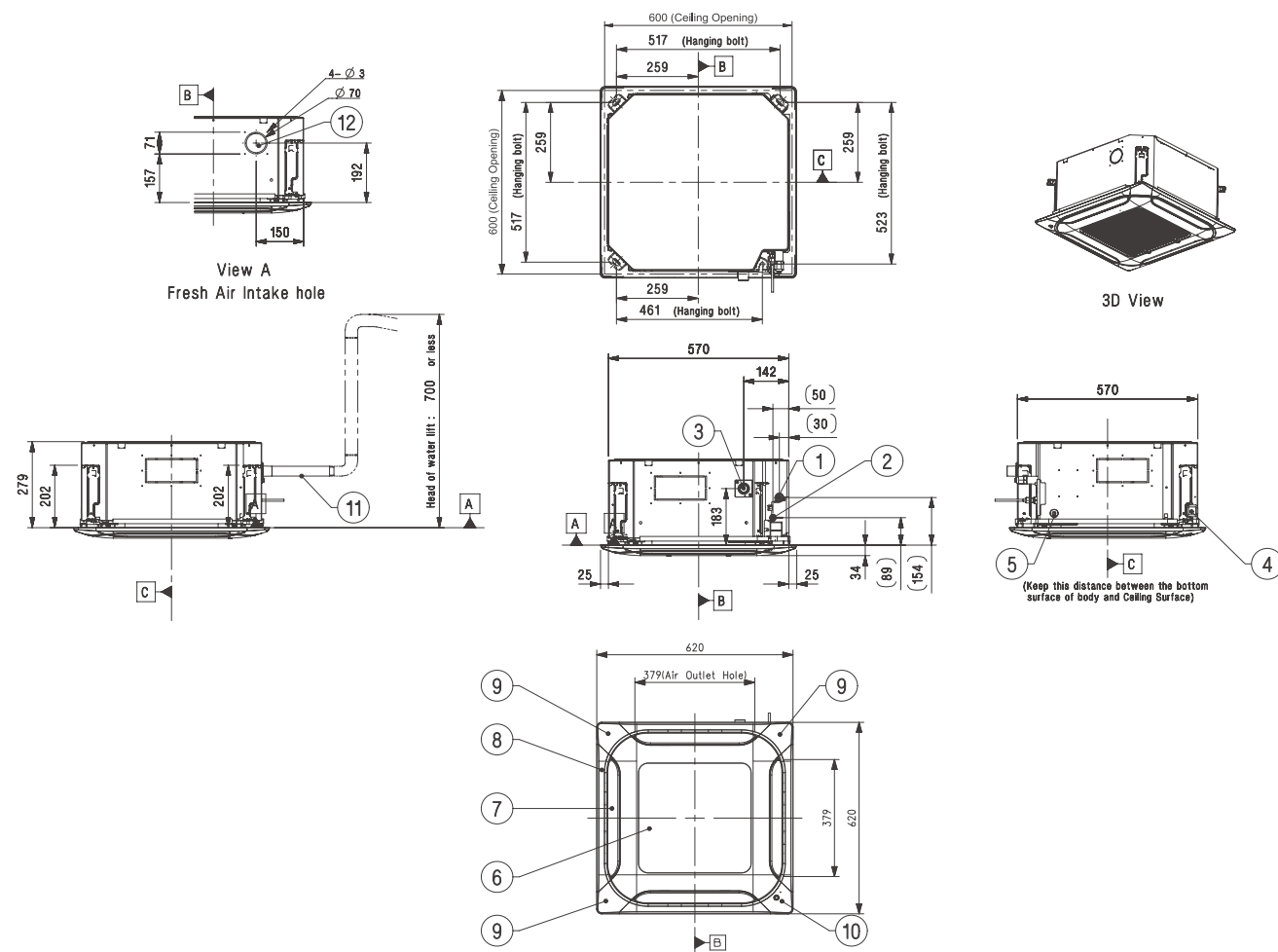

# CEILING CASSETTE

H-INVERTER (R32)

## UT18FH.NB0

(Unit : mm)

Part Name
1 Gas Pipe Connection
2 Liquid Pipe Connection
3 Drain Pipe Connection
4 Power and Communication cable routing hole
5 Wired remote controller wire routing hole
6 Air Inlet
7 Air Outlet
8 Decoration Panel (Accessory)
9 Decoration Corner Cover
10 Flexible Drain Hose
11 Fresh air Intake Hole

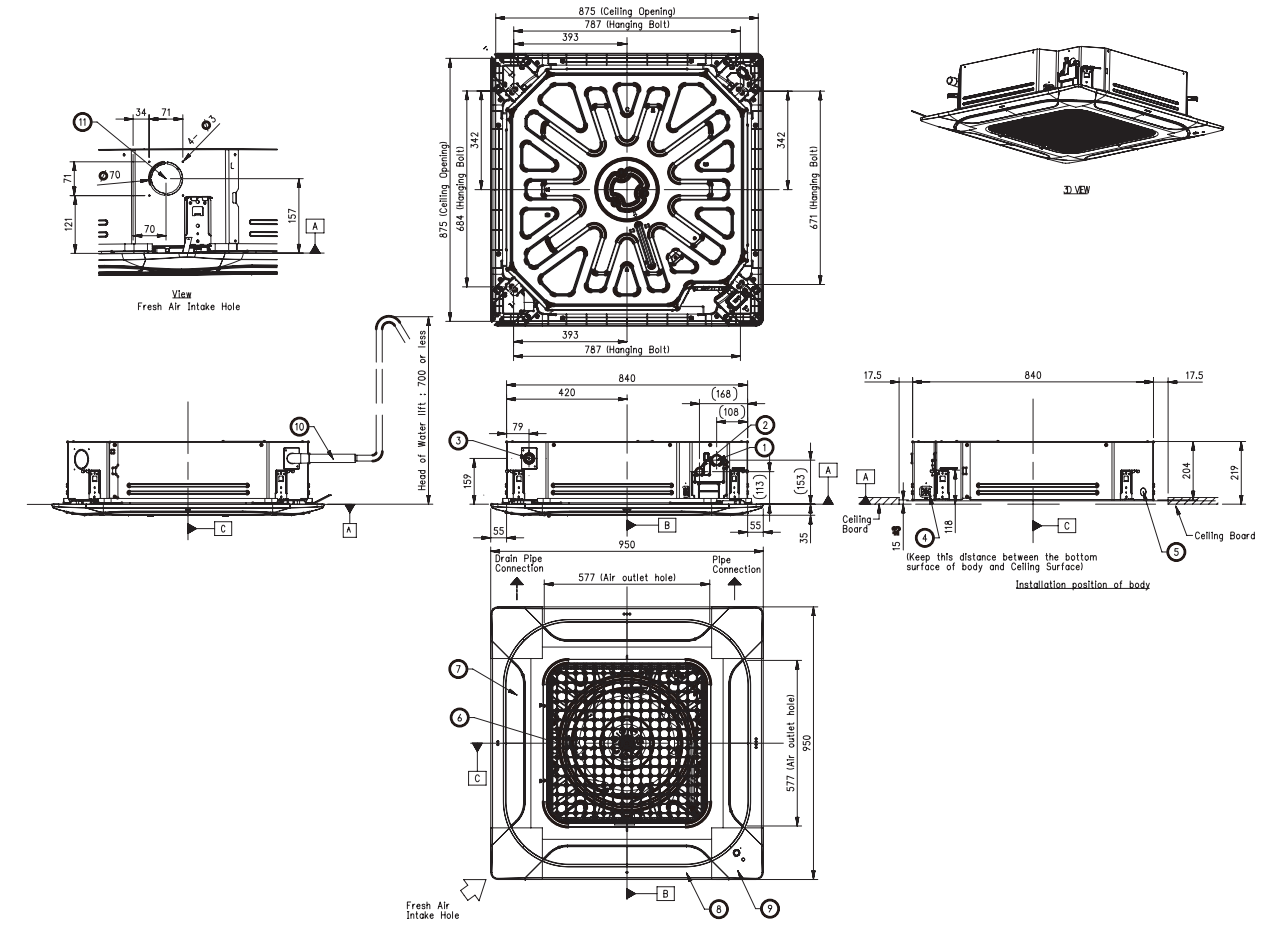

# CEILING CASSETTE

H-INVERTER (R32)

UT24FH.NA0 / UT30FH.NA0 / UT36FH.NA0 / UT42FH.NA0  
UT48FH.NA0 / UT60FH.NA0

(Unit : mm)

Part Name	Part Name
1	Gas Pipe Connection
2	Liquid Pipe Connection
3	Drain Pipe Connection
4	Power and Communication cable routing hole
5	Wired remote controller wire routing hole
6	Air Inlet
7	Air Outlet
8	Decoration Panel (Accessory)
9	Decoration Corner Cover
10	Flexible Drain Hose
11	Fresh air Intake Hole

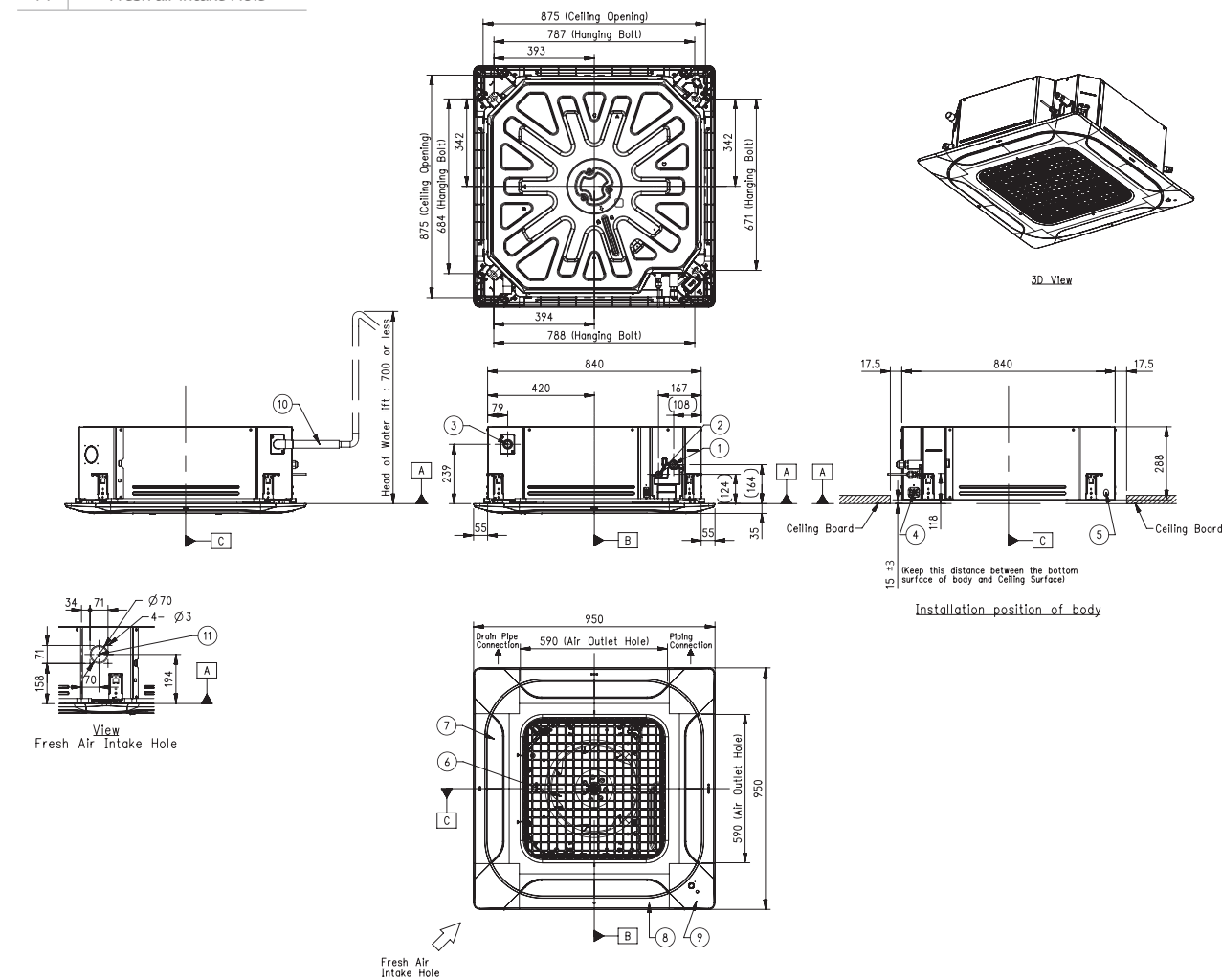

# CEILING CASSETTE

STANDARD INVERTER (R32)

CT09F.NR0 / CT12F.NR0

(Unit : mm)

Part Name	Part Name
1	Gas Pipe Connection
2	Liquid Pipe Connection
3	Drain Pipe Connection
4	Power and Communication Cable Routing Hole
5	Wired Remote Controller Wire Routing Hole
6	Air Intake
7	Air Outlet
8	Decoration Panel (Accessory)
9	Decoration Corner Cover
10	Decoration Corner Display Cover
11	Flexible Drain Hose
12	Fresh Air Intake Hole

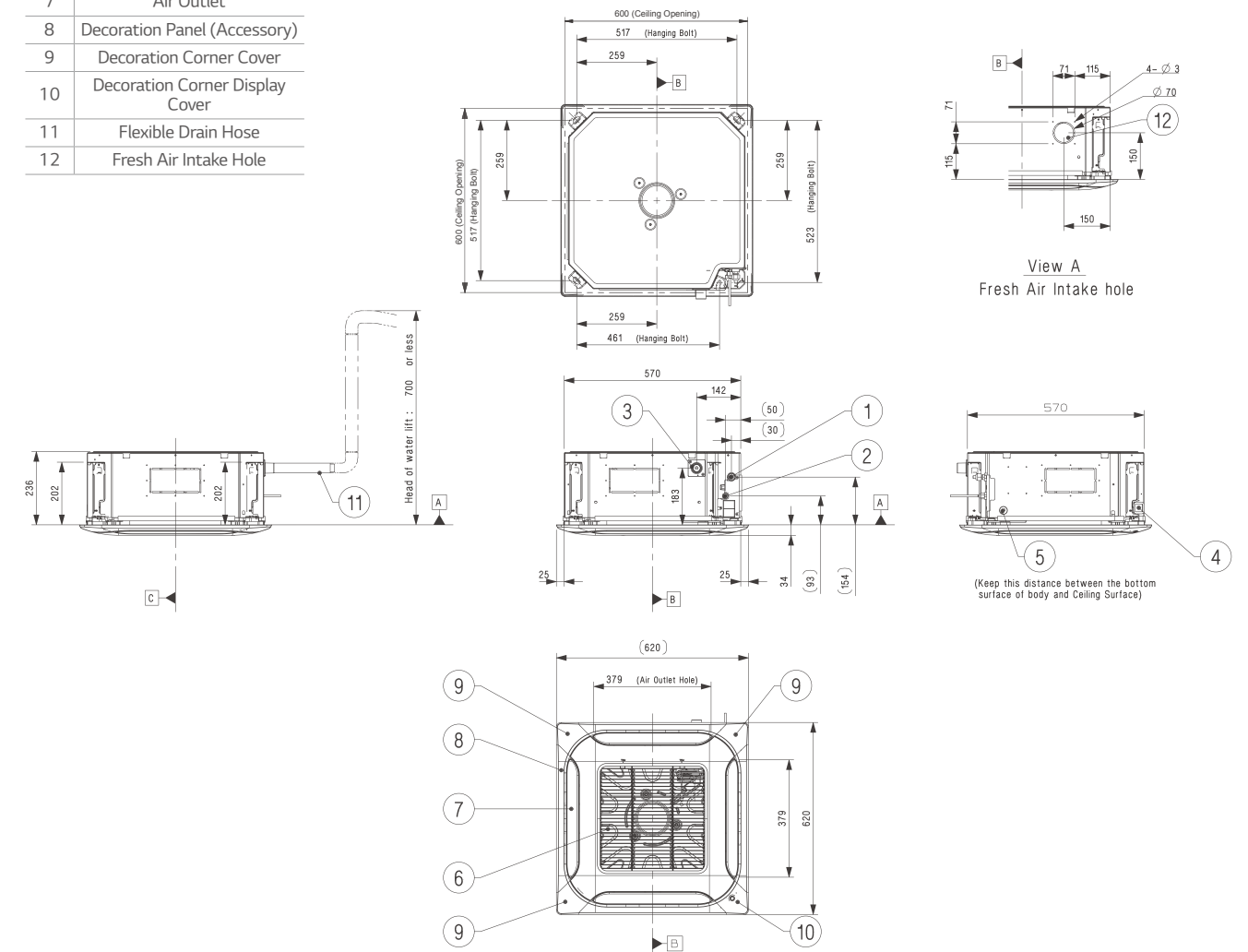

# CEILING CASSETTE

STANDARD / COMPACT INVERTER (R32)

## CT18F.NQ0

(Unit : mm)

Part Name
1 Gas Pipe Connection
2 Liquid Pipe Connection
3 Drain Pipe Connection
4 Power and Communication cable routing hole
5 Wired remote controller wire routing hole
6 Air Intake
7 Air Outlet
8 Decoration Panel (Accessory)
9 Decoration Corner Cover
10 Decoration Coner Display Cover
11 Flexible Drain Hose
12 Fresh air Intake Hole

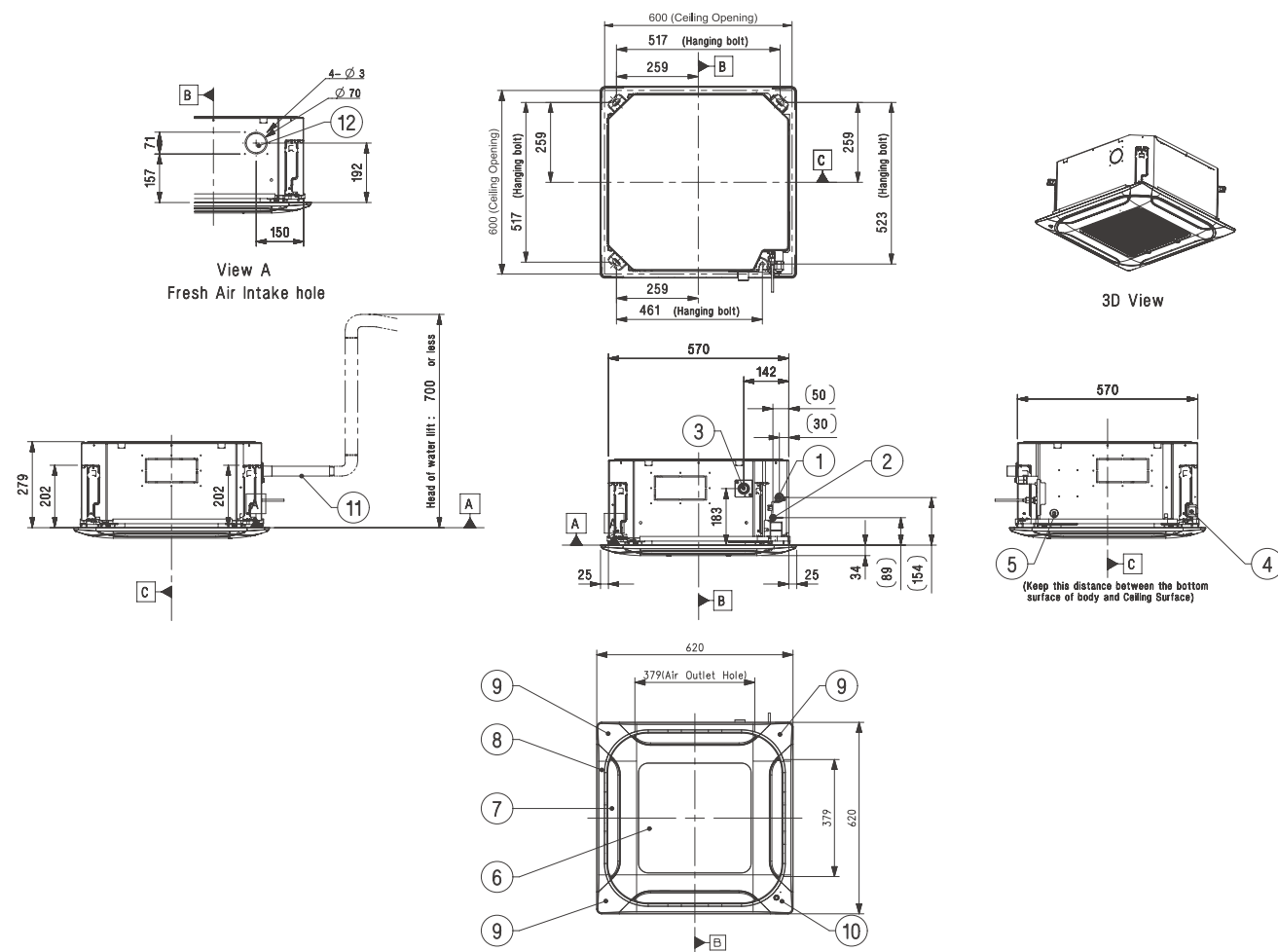

# CEILING CASSETTE

STANDARD / COMPACT INVERTER (R32)

## CT24F.NB0 / UT30F.NB0

(Unit : mm)

Part Name
1 Gas Pipe Connection
2 Liquid Pipe Connection
3 Drain Pipe Connection
4 Power and Communication Cable Routing Hole
5 Wired Remote Controller Wire Routing Hole
6 Air Inlet
7 Air Outlet
8 Decoration Panel (Accessory)
9 Decoration Corner Cover
10 Flexible Drain Hose
11 Fresh Air Intake Hole

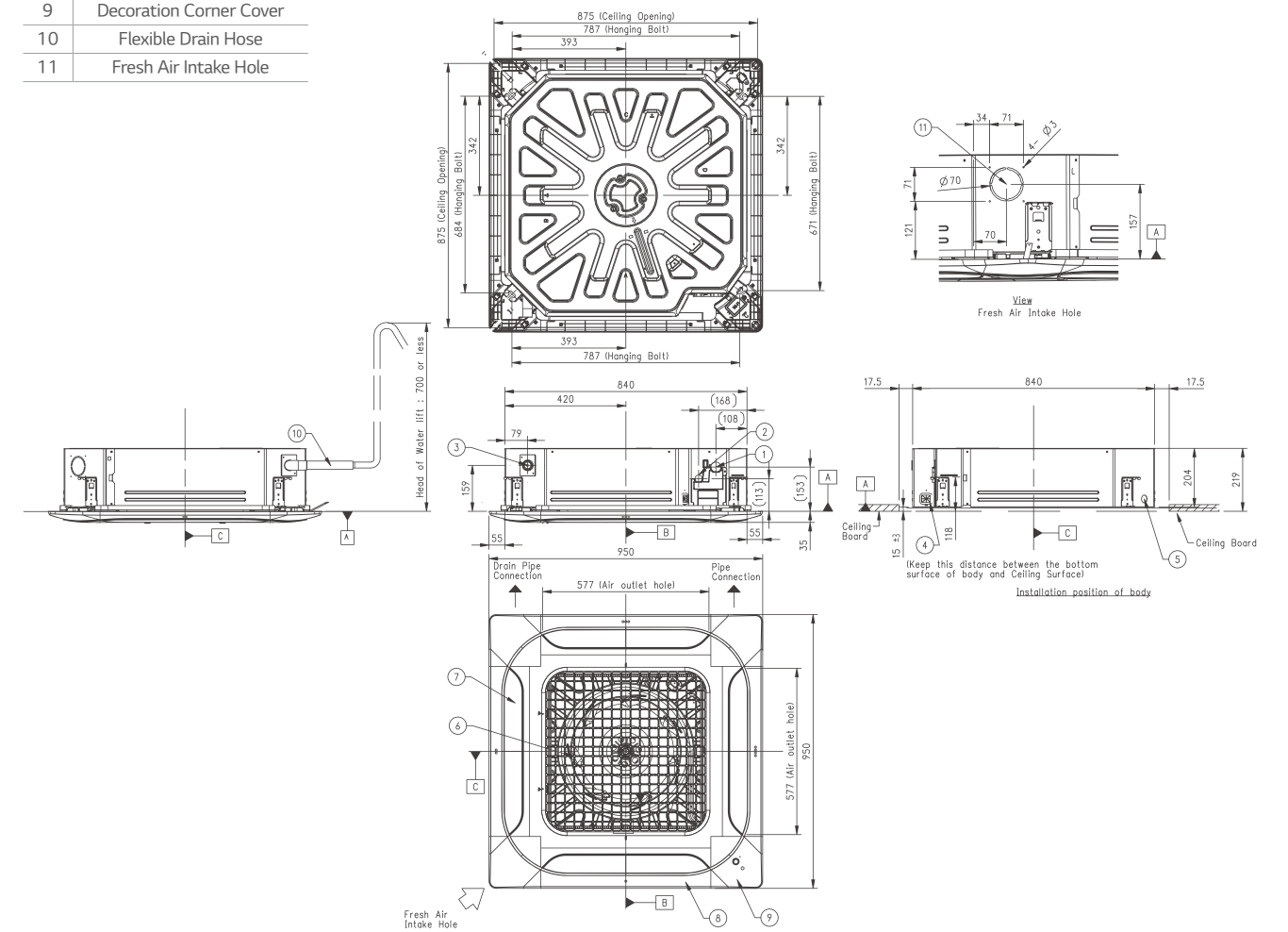

# CEILING CASSETTE

STANDARD / COMPACT INVERTER (R32)

## UT36F.NA0

(Unit : mm)

Part Name
1 Gas Pipe Connection
2 Liquid Pipe Connection
3 Drain Pipe Connection
4 Power and Communication Cable Routing Hole
5 Wired Remote Controller Wire Routing Hole
6 Air Inlet
7 Air Outlet
8 Decoration Panel (Accessory)
9 Decoration Corner Cover
10 Flexible Drain Hose
11 Fresh Air Intake Hole

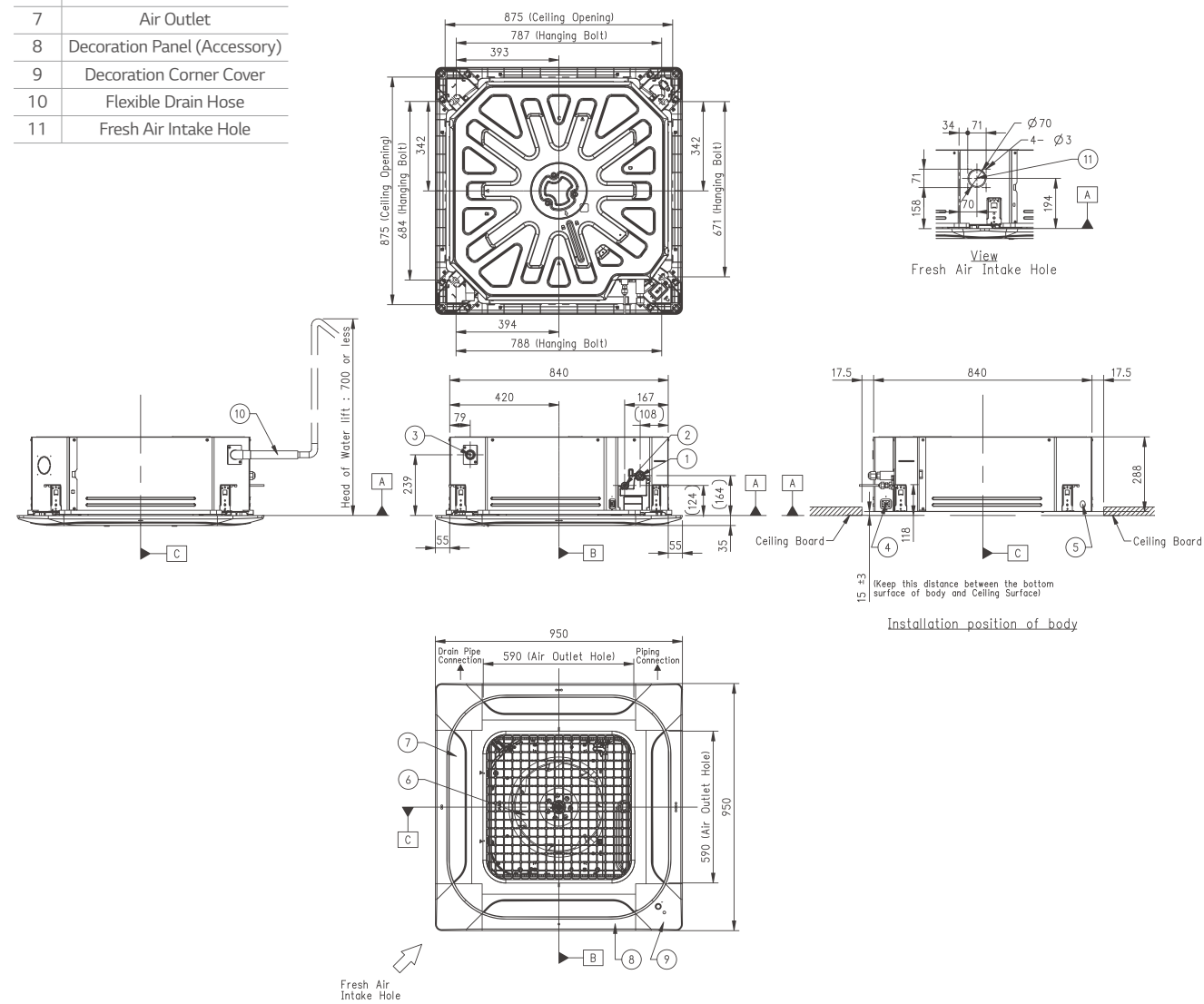

# CEILING CASSETTE

STANDARD INVERTER (R32)

## UT42F.NA0 / UT48F.NA0 / UT60F.NA0

(Unit : mm)

Part Name
1 Gas Pipe Connection
2 Liquid Pipe Connection
3 Drain Pipe Connection
4 Power and Communication Cable Routing Hole
5 Wired Remote Controller Wire Routing Hole
6 Air Inlet
7 Air Outlet
8 Decoration Panel (Accessory)
9 Decoration Corner Cover
10 Flexible Drain Hose
11 Fresh Air Intake Hole

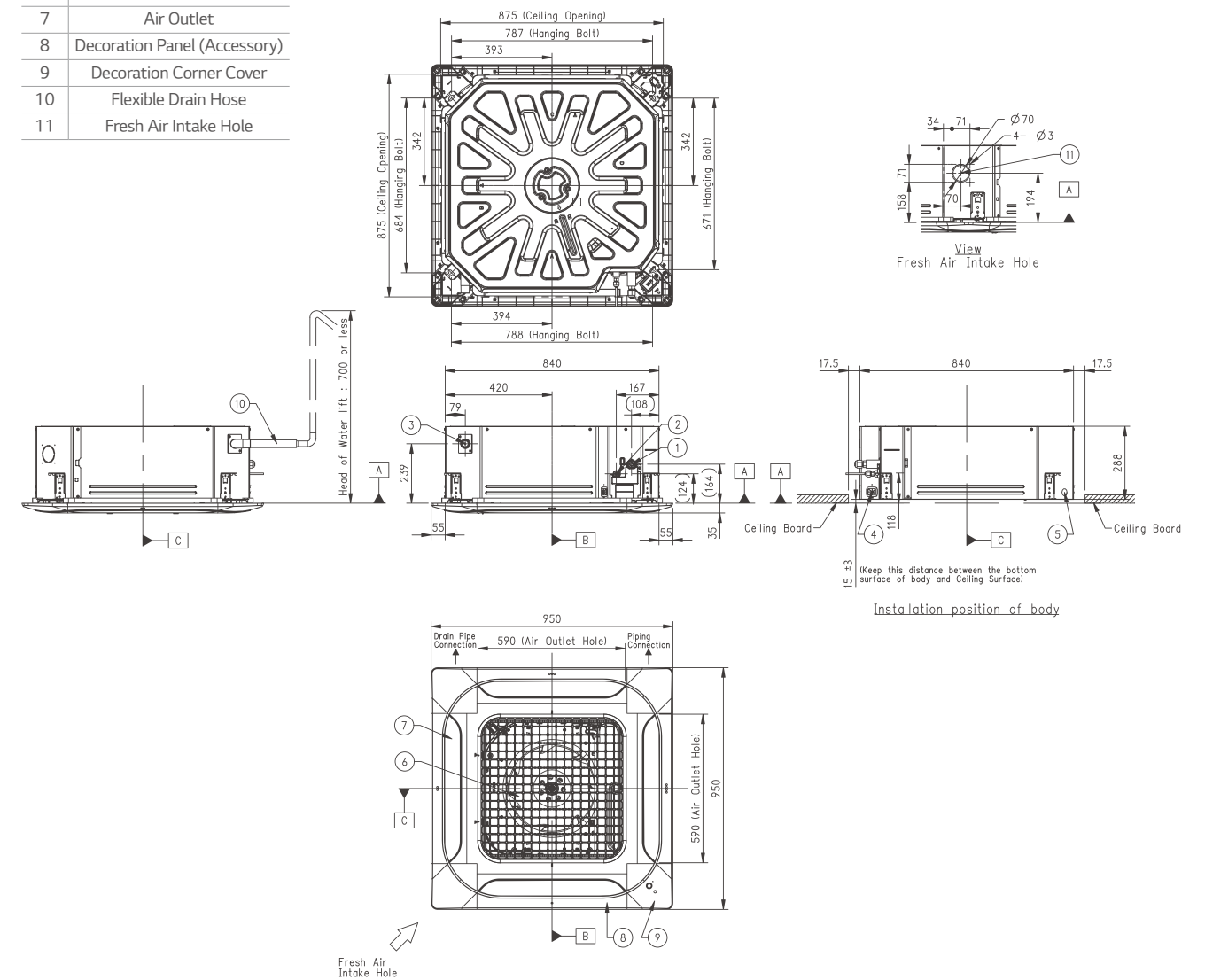



# CEILING CONCEALED DUCT

H-INVERTER (R32) / MID STATIC

## UM12FH.N10 / UM18FH.N10

(Unit : mm)

Part Name	Part Name
1	Gas Pipe Connection
2	Liquid Pipe Connection
3	Drain Pipe Connection
4	Power and Communication Cable Routing Hole
5	Remote Controller Cable Hole
6	Air Inlet
7	Air Outlet
8	Air Filters
9	Control Cover

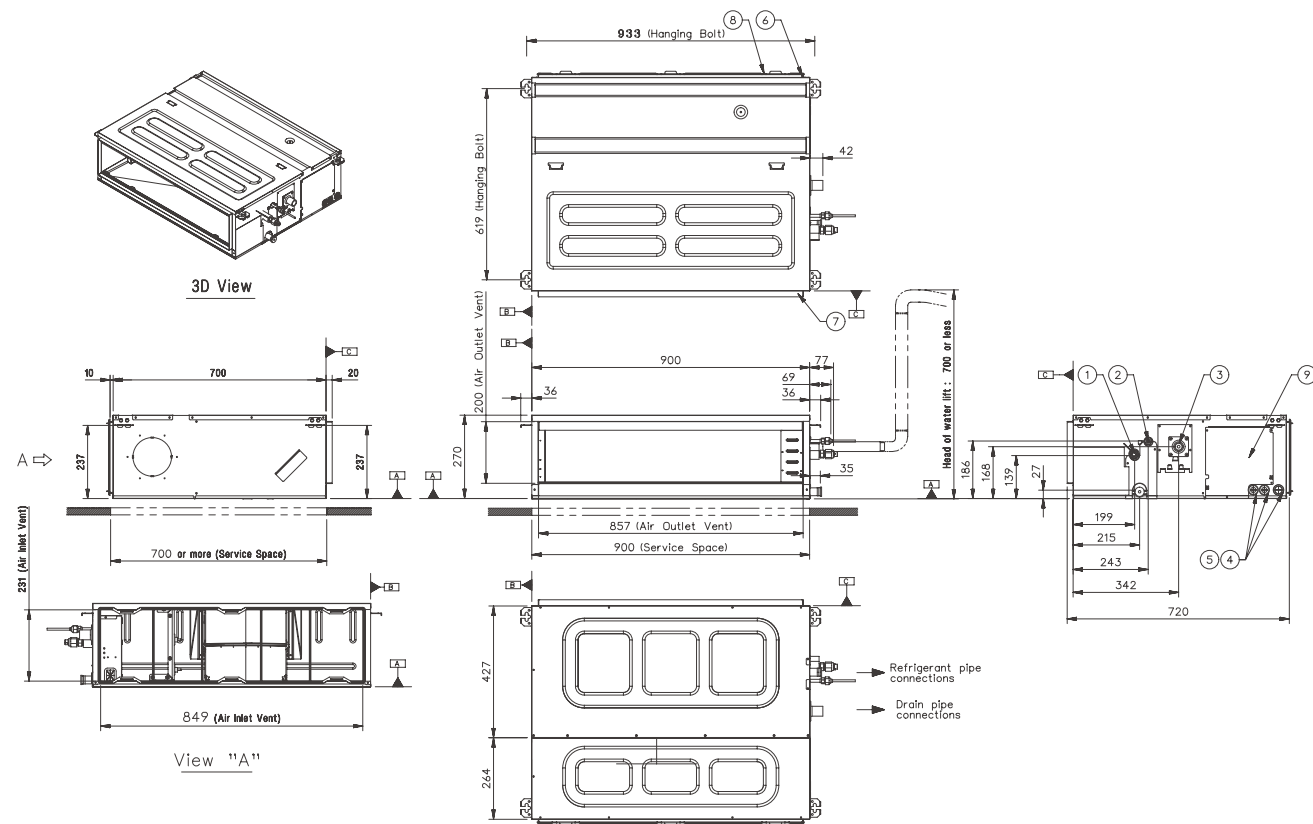

# CEILING CONCEALED DUCT

H-INVERTER (R32) / MID STATIC

## UM24FH.N20 / UM30FH.N20

(Unit : mm)

Part Name	Part Name
1	Gas Pipe Connection
2	Liquid Pipe Connection
3	Drain Pipe Connection
4	Power and Communication Cable Hole
5	Remote Controller Cable hole
6	Air Inlet
7	Air Outlet
8	Air Filters
9	Control Cover
10	Flexible Drain Hose

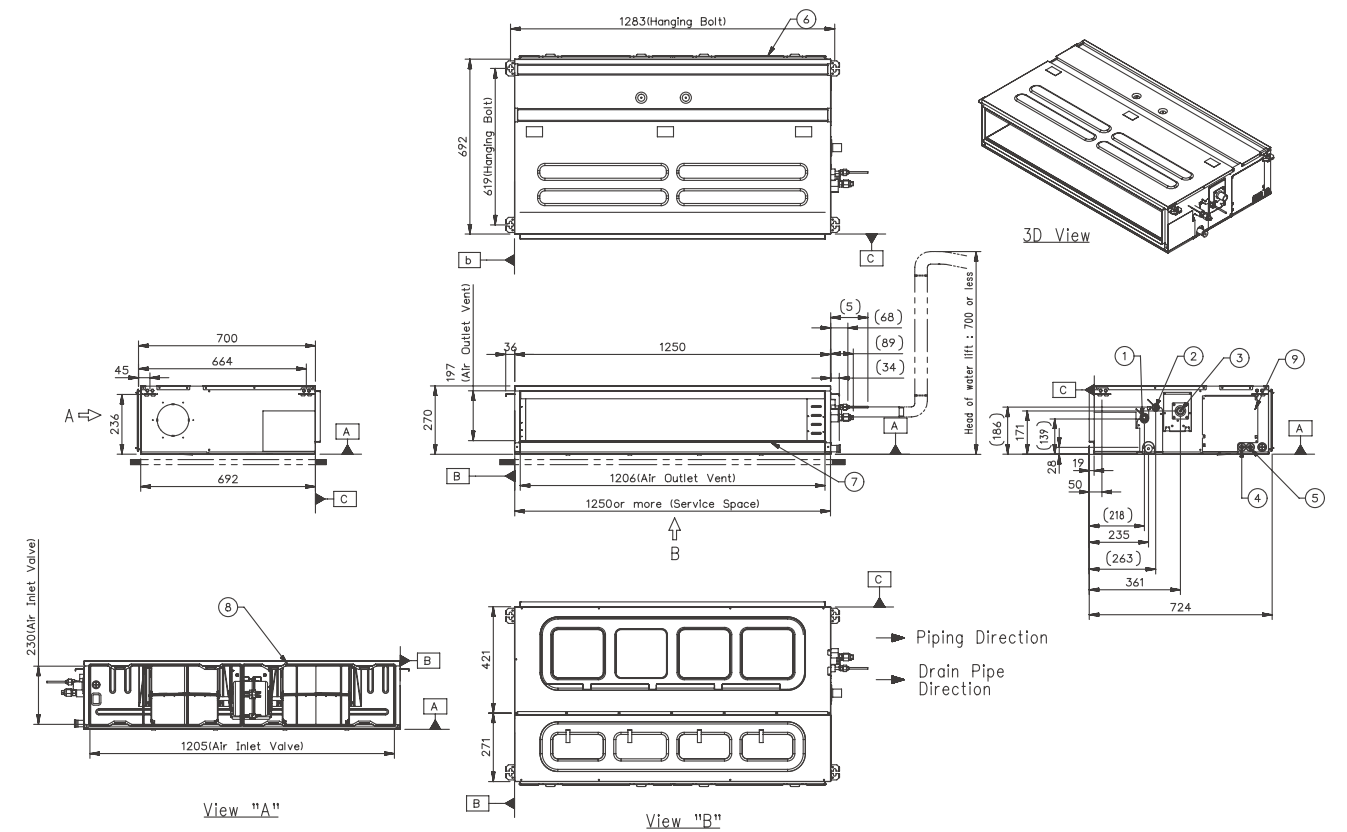

# CEILING CONCEALED DUCT

H-INVERTER (R32) / MID STATIC

## UM36FH.N30 / UM42FH.N30 / UM48FH.N30

(Unit : mm)

Part Name	Part Name
1	Gas Pipe Connection
2	Liquid Pipe Connection
3	Drain Pipe Connection
4	Power and Communication Cable Hole
5	Remote Controller Cable Hole
6	Air Inlet
7	Air Outlet
8	Air Filters
9	Control Cover

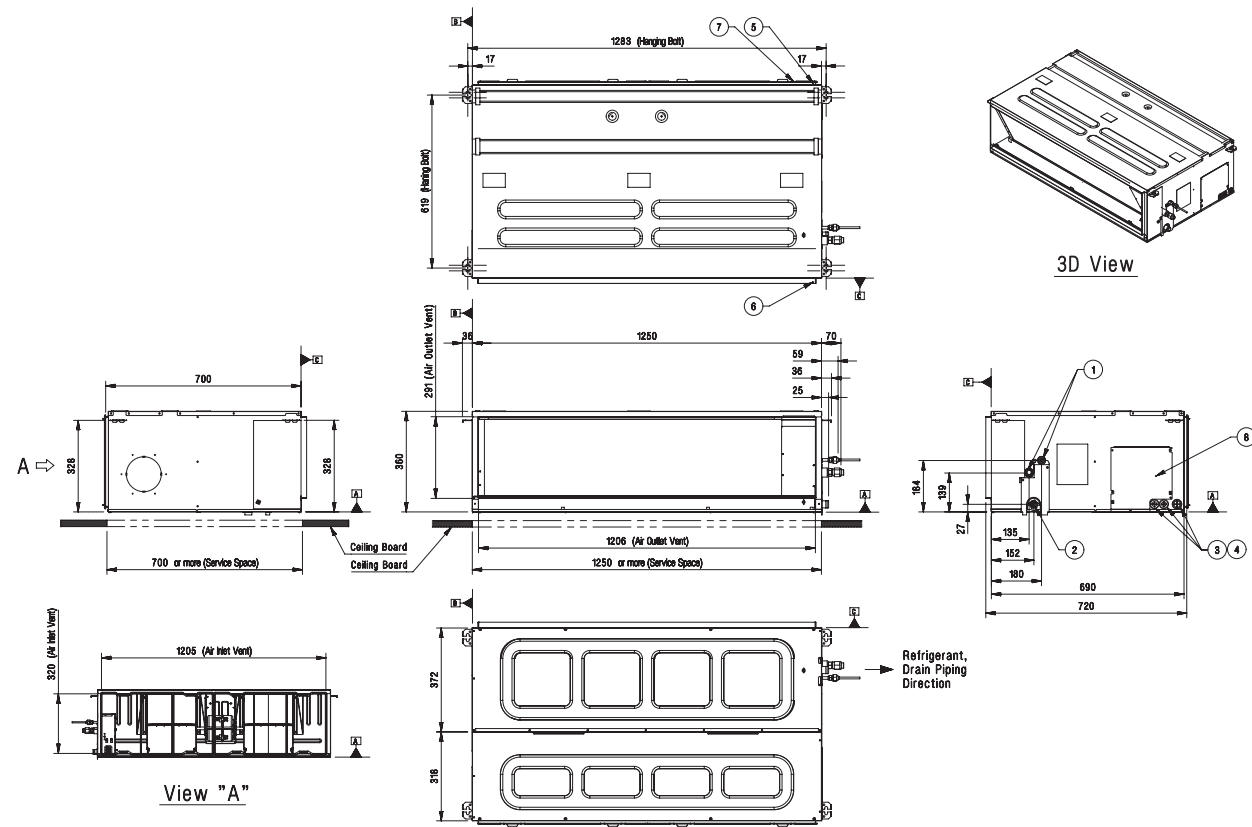

# CEILING CONCEALED DUCT

H-INVERTER (R32) / LOW STATIC

## UL12FH.N50

(Unit : mm)

Part Name	Part Name
1	Liquid Pipe Connection
2	Gas Pipe Connection
3	Drain Pipe Connection
4	Power supply Connection
5	Air Discharge
6	Air Suction

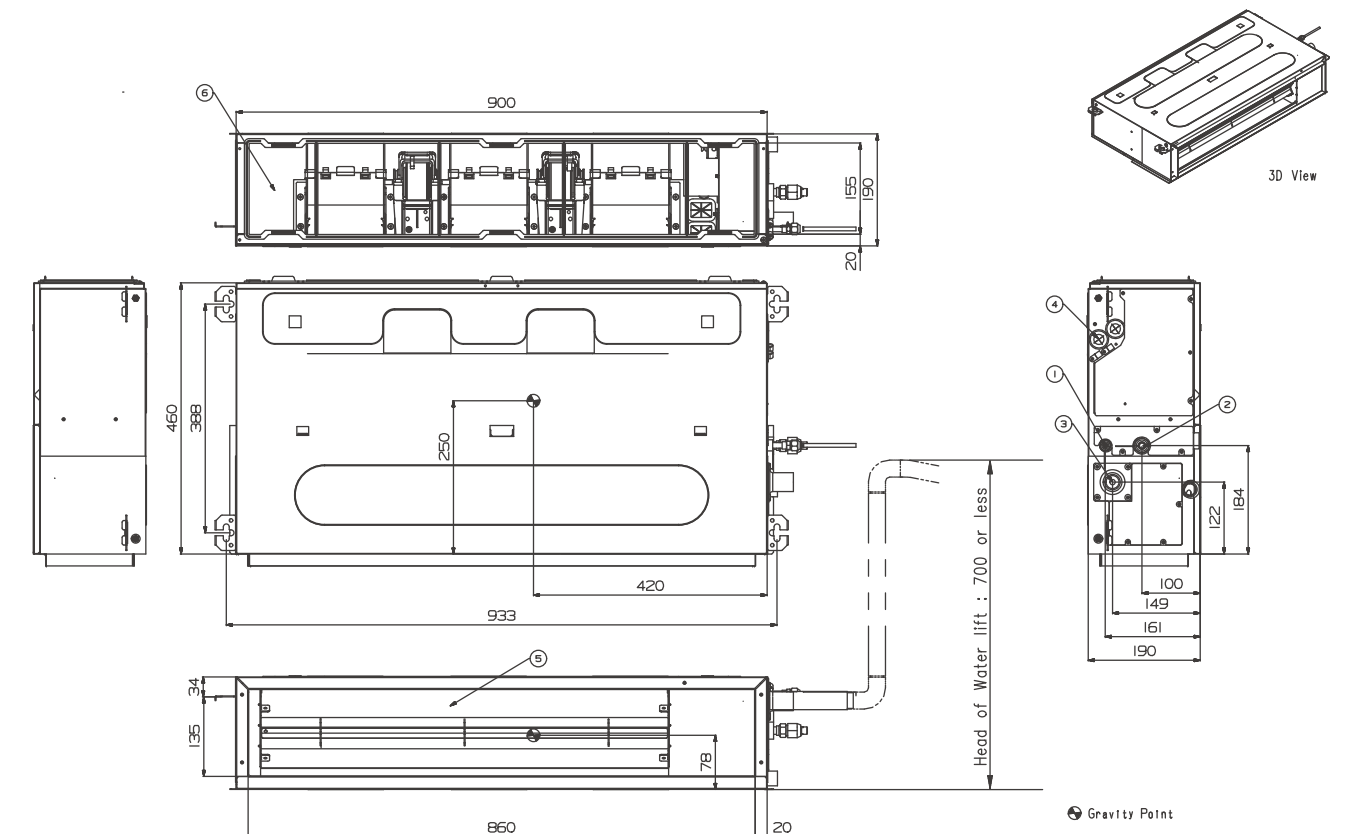

# CEILING CONCEALED DUCT

H-INVERTER (R32) / LOW STATIC

## UL18FH.N30

(Unit : mm)

Part Name
1 Liquid Pipe Connection
2 Gas Pipe Connection
3 Drain Pipe Connection
4 Power Supply Connection
5 Air Discharge
6 Air Suction

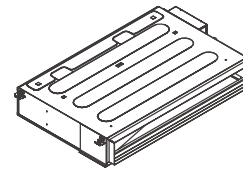
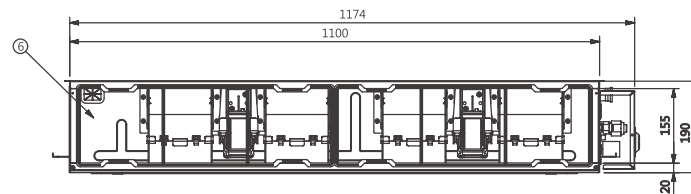

3D-VIEW

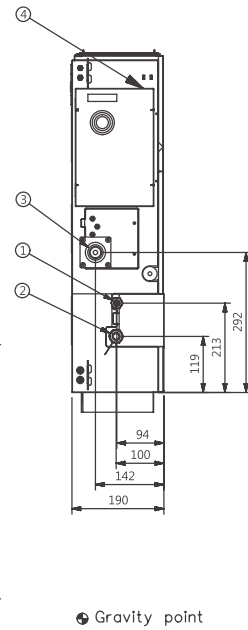
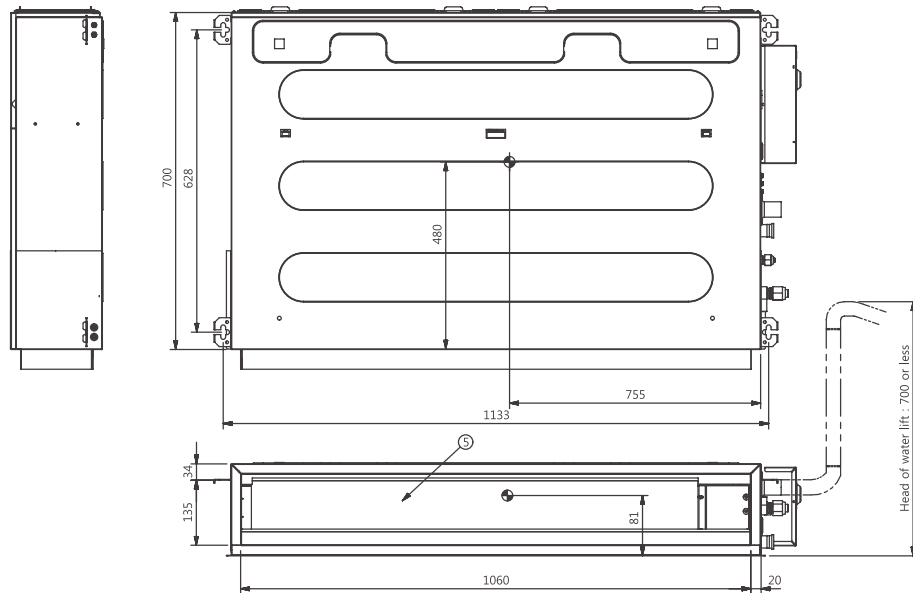

Gravity point

# CEILING CONCEALED DUCT

STANDARD / COMPACT INVERTER (R32) / MID STATIC

## CM18F.N10 / CM24F.N10 / UM30F.N10

(Unit : mm)

Part Name
1 Gas Pipe Connection
2 Liquid Pipe Connection
3 Drain Pipe Connection
4 Power and Communication Cable Hole
5 Remote Controller Cable Hole
6 Air Inlet
7 Air Outlet
8 Air Filters
9 Control Cover

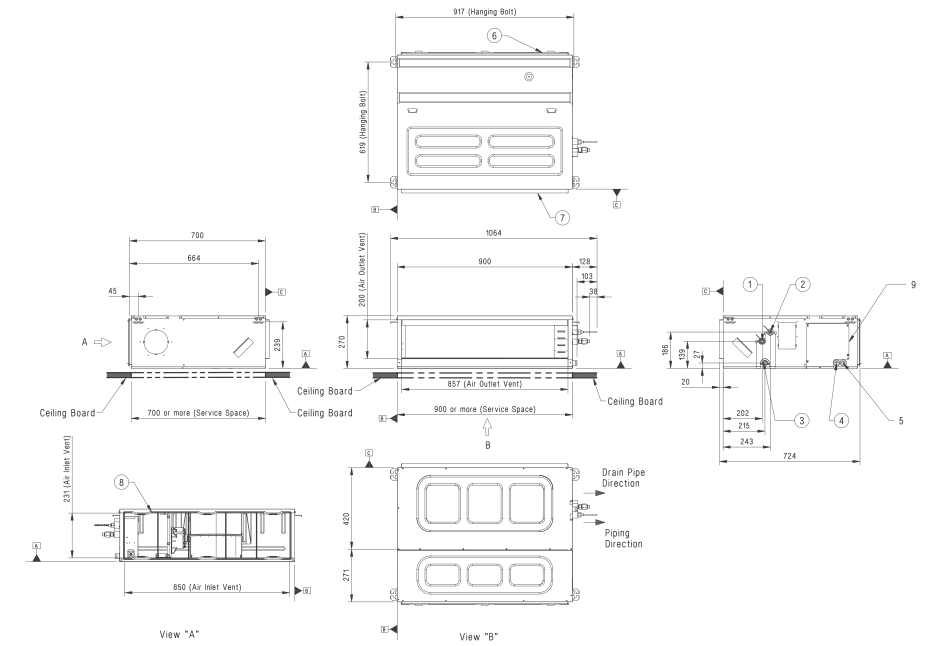

## UM36F.N20

(Unit : mm)

Part Name
1 Liquid Pipe Connection
2 Gas Pipe Connection
3 Drain Pipe Connection
4 Power Supply Connection
5 Air Discharge
6 Air Suction

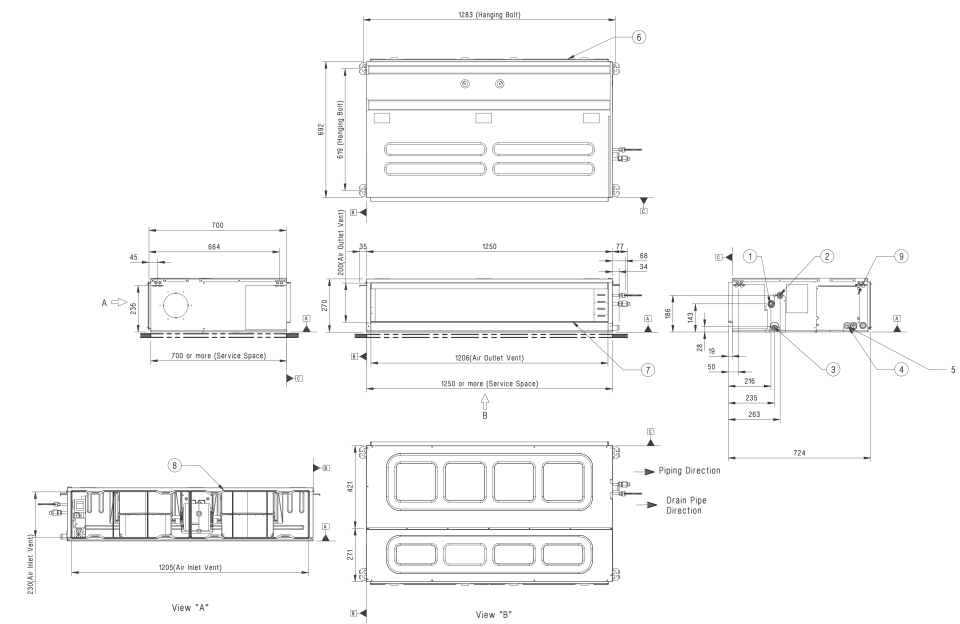

# CEILING CONCEALED DUCT

STANDARD INVERTER (R32) / MID STATIC

## UM42F.N20

(Unit : mm)

Part Name
1 Liquid Pipe Connection
2 Gas Pipe Connection
3 Drain Pipe Connection
4 Power Supply Connection
5 Air Discharge
6 Air Suction

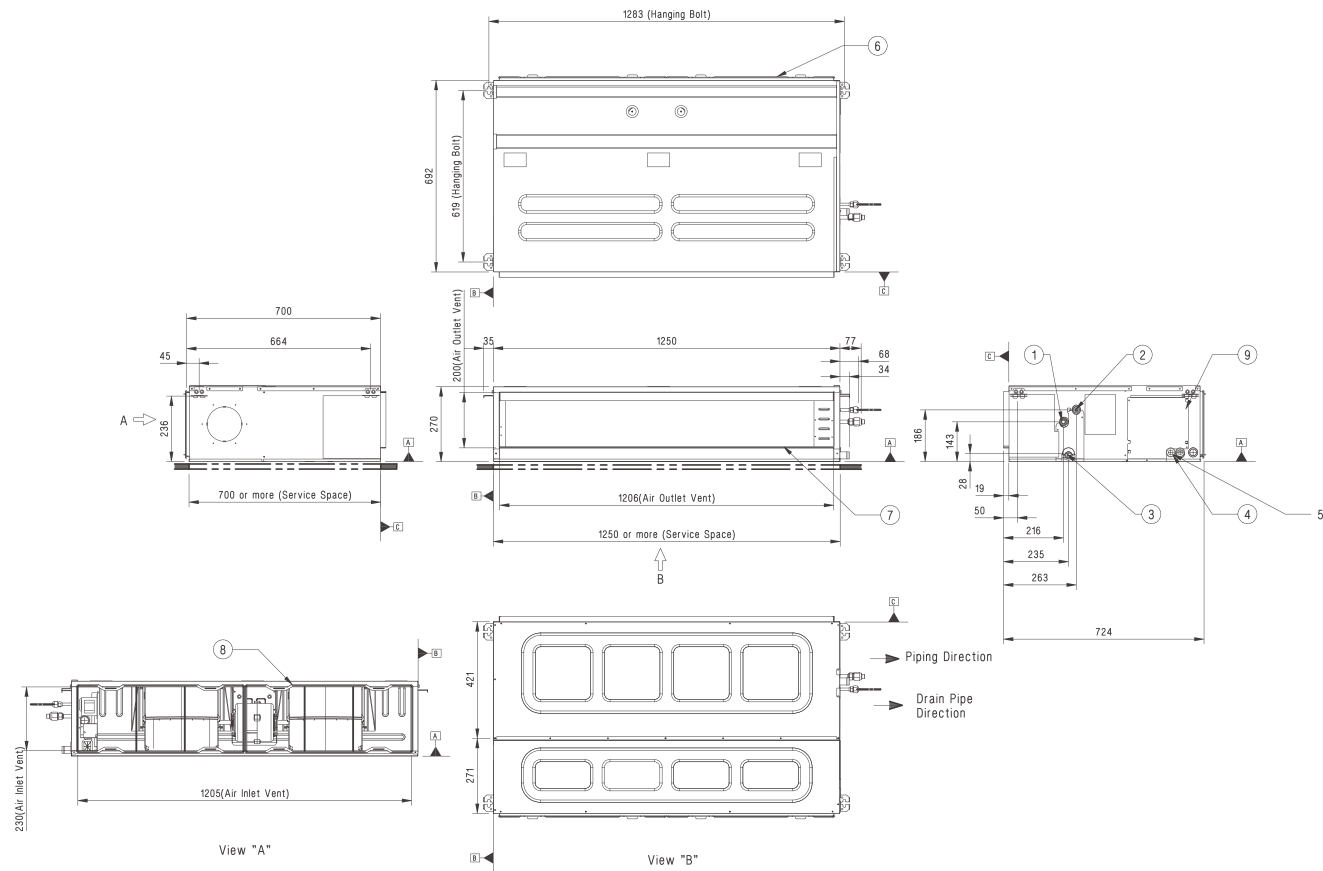

# CEILING CONCEALED DUCT

STANDARD INVERTER (R32) / MID STATIC

## UM48F.N30 / UM60F.N30

(Unit : mm)

Part Name
1 Gas Pipe Connection
2 Liquid Pipe Connection
3 Drain Pipe Connection
4 Power and Communication Cable Hole
5 Remote Controller Cable Hole
6 Air Inlet
7 Air Outlet
8 Air Filters
9 Control Cover

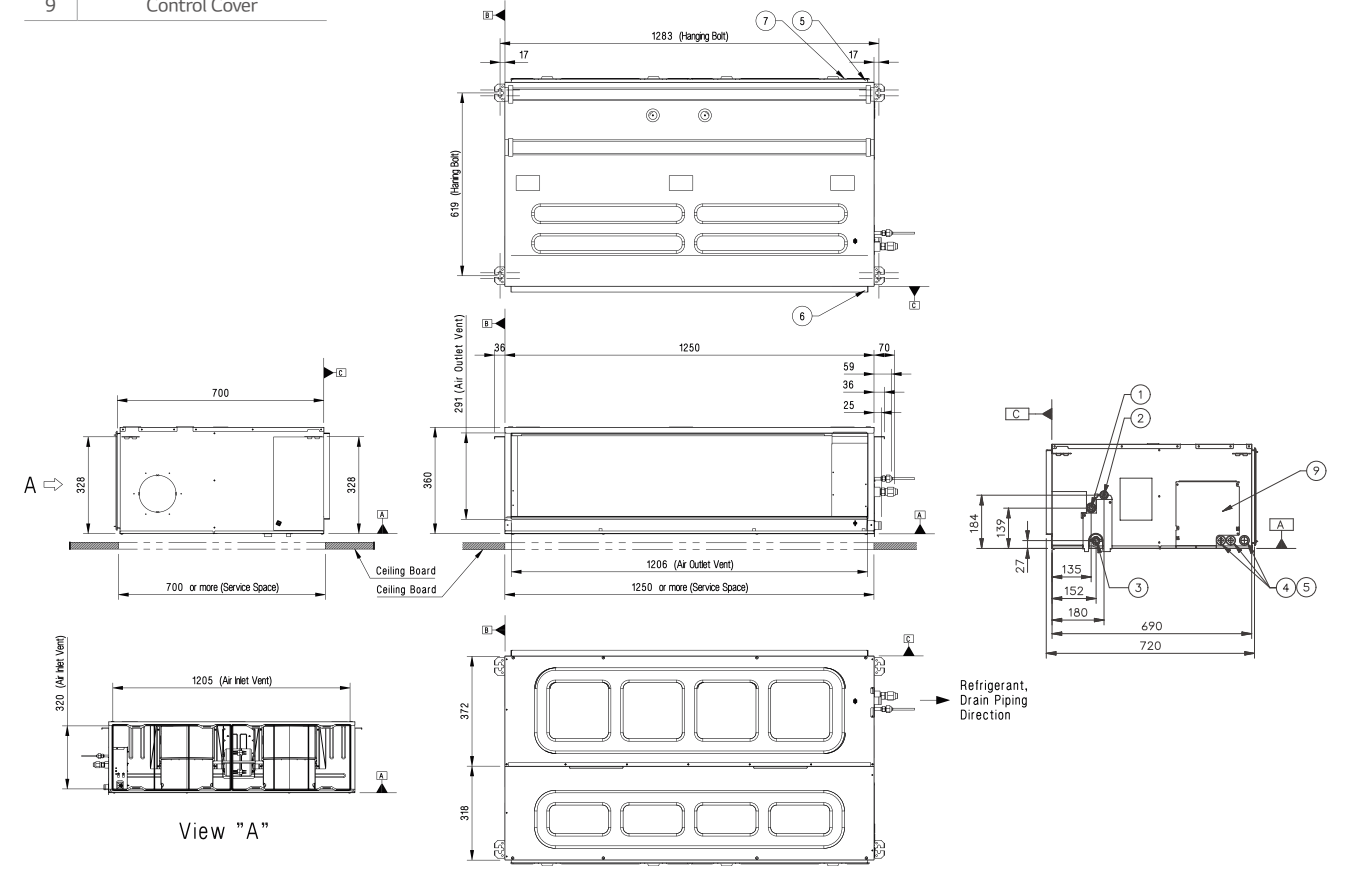

# CEILING CONCEALED DUCT

STANDARD INVERTER (R32) / LOW STATIC

## CL09F.N50 / CL12F.N50

(Unit : mm)

Part Name
1 Liquid pipe connection
2 Gas pipe connection
3 Drain pipe connection
4 Power supply connection
5 Air discharge
6 Air suction

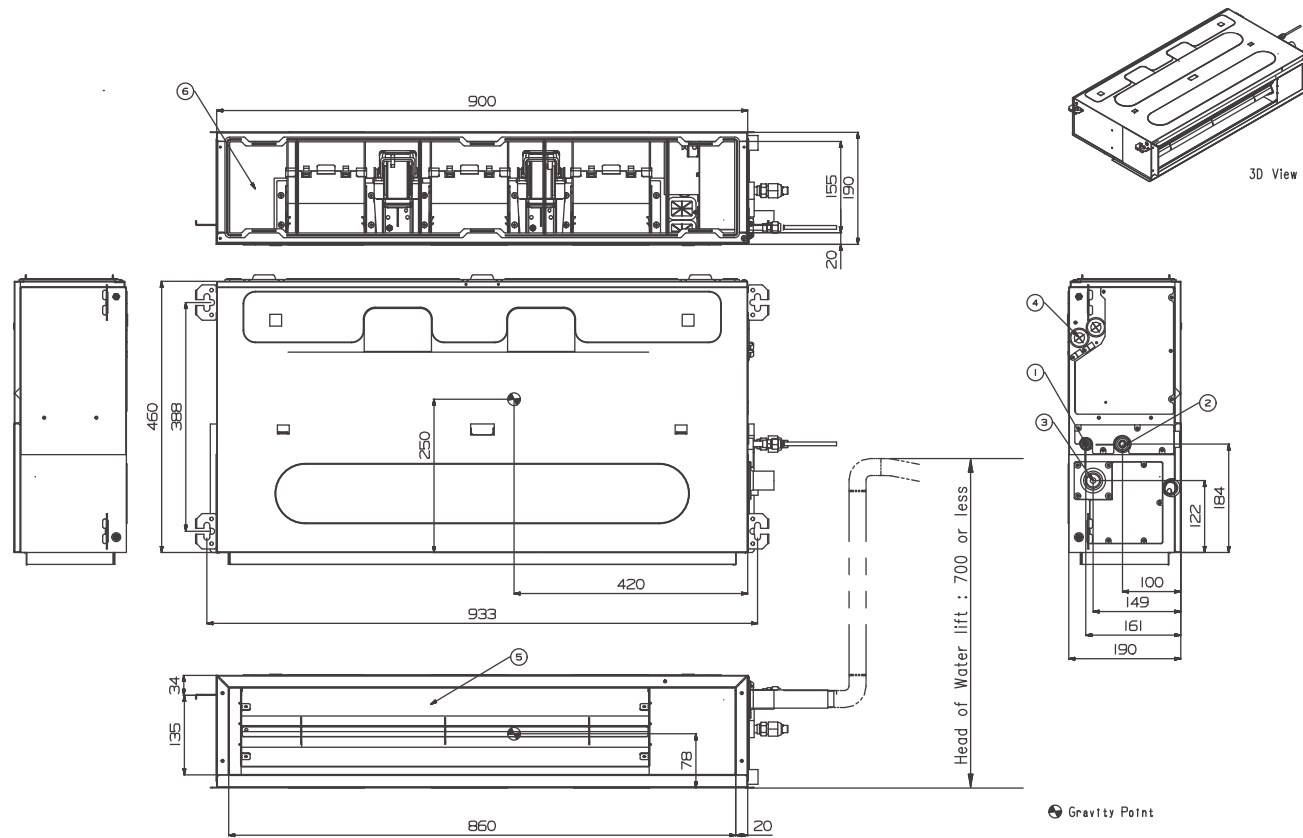

# CEILING CONCEALED DUCT

STANDARD / COMPACT INVERTER (R32) / LOW STATIC

## CL18F.N60

(Unit : mm)

Part Name
1 Liquid pipe connection
2 Gas pipe connection
3 Drain pipe connection
4 Power supply connection
5 Air discharge
6 Air suction

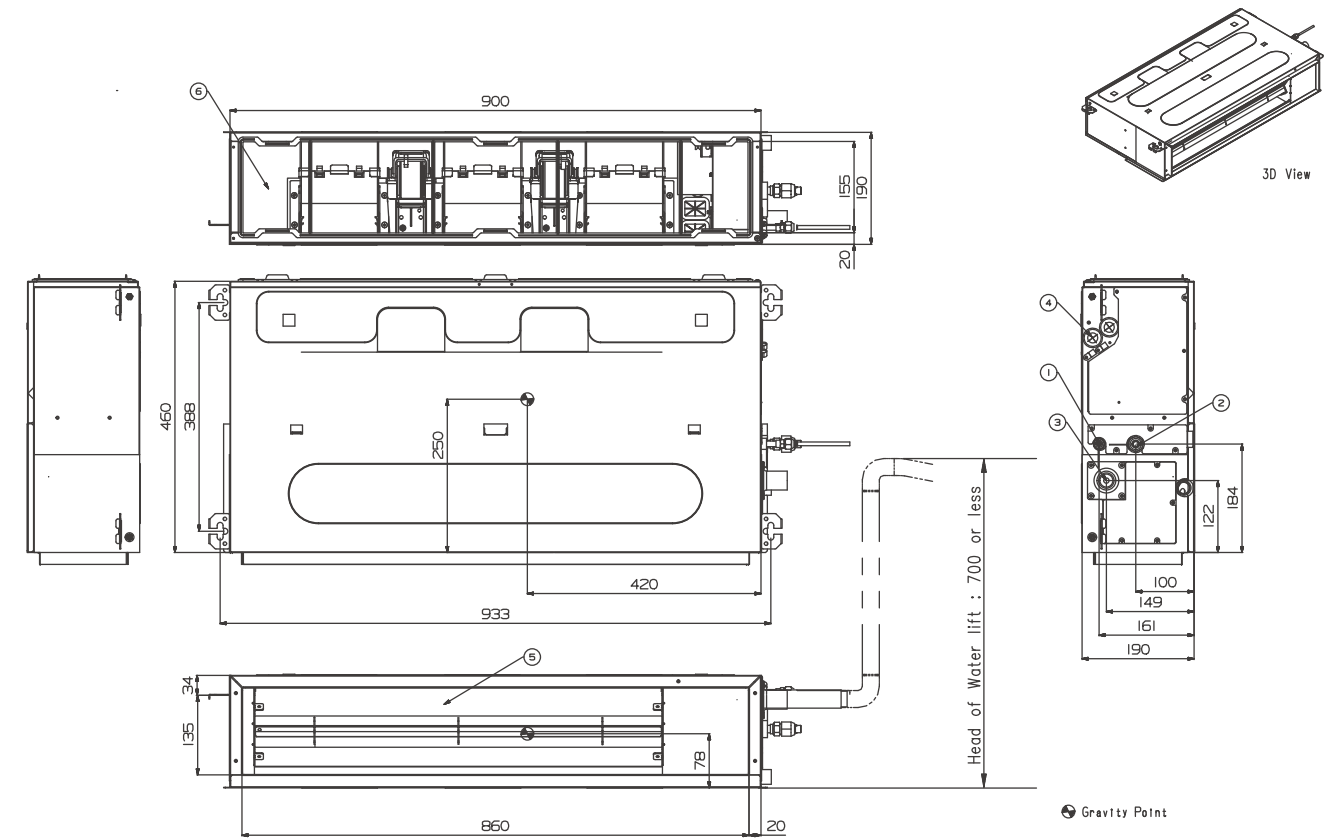

# CEILING CONCEALED DUCT

STANDARD / COMPACT INVERTER (R32) / LOW STATIC

## CL24F.N30

(Unit : mm)

Part Name
1 Liquid pipe connection
2 Gas pipe connection
3 Drain pipe connection
4 Power supply connection
5 Air discharge
6 Air suction

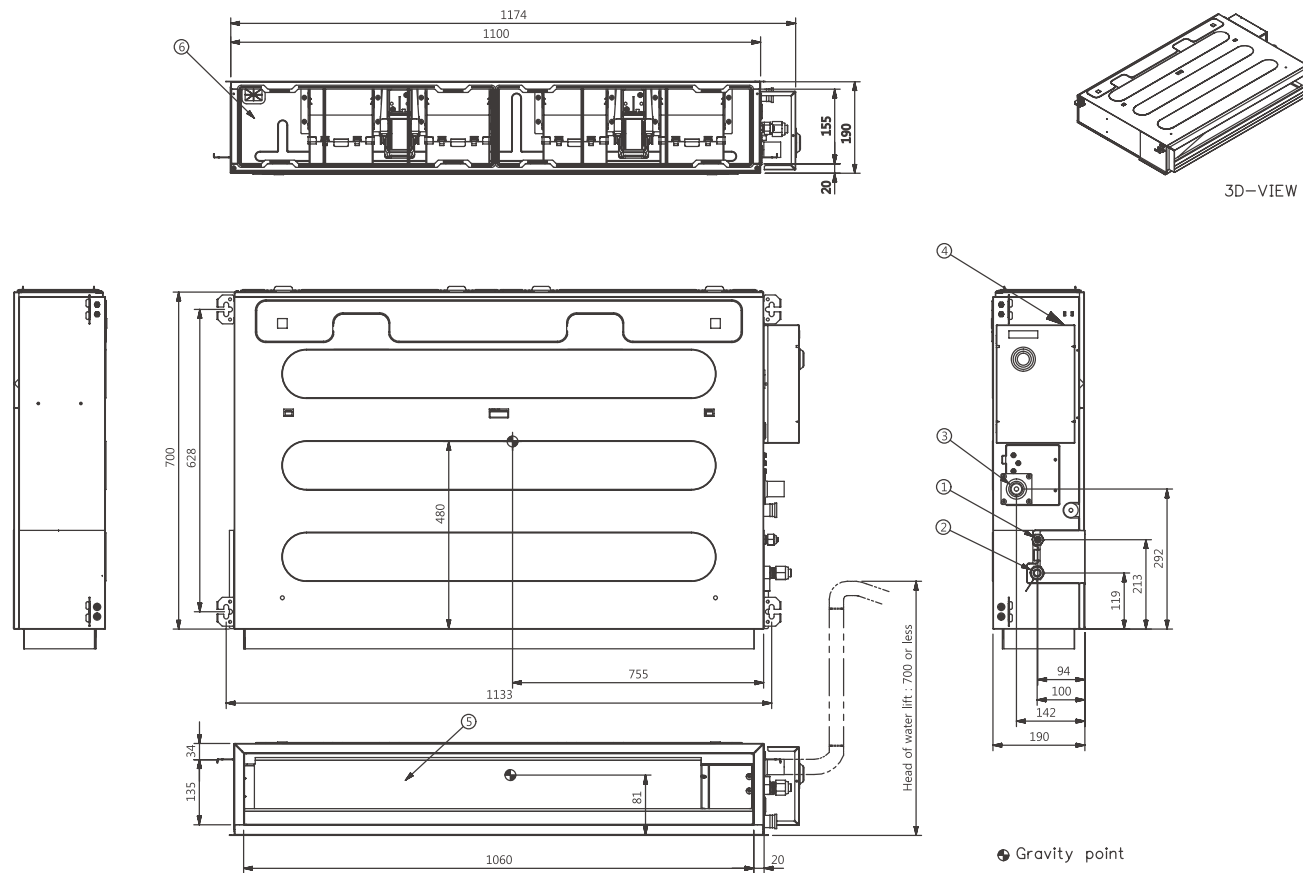

# CEILING CONCEALED DUCT

STANDARD INVERTER (R410A) / HIGH STATIC

## UB70.N94 / UB85.N94

(Unit : mm)

Part Name
1 Air suction flange
2 Air discharge flange
3 Control Box
4 Gas piping connection
5 Liquid pipe connection
6 Drain pipe connection
7 Drain pump (Option)

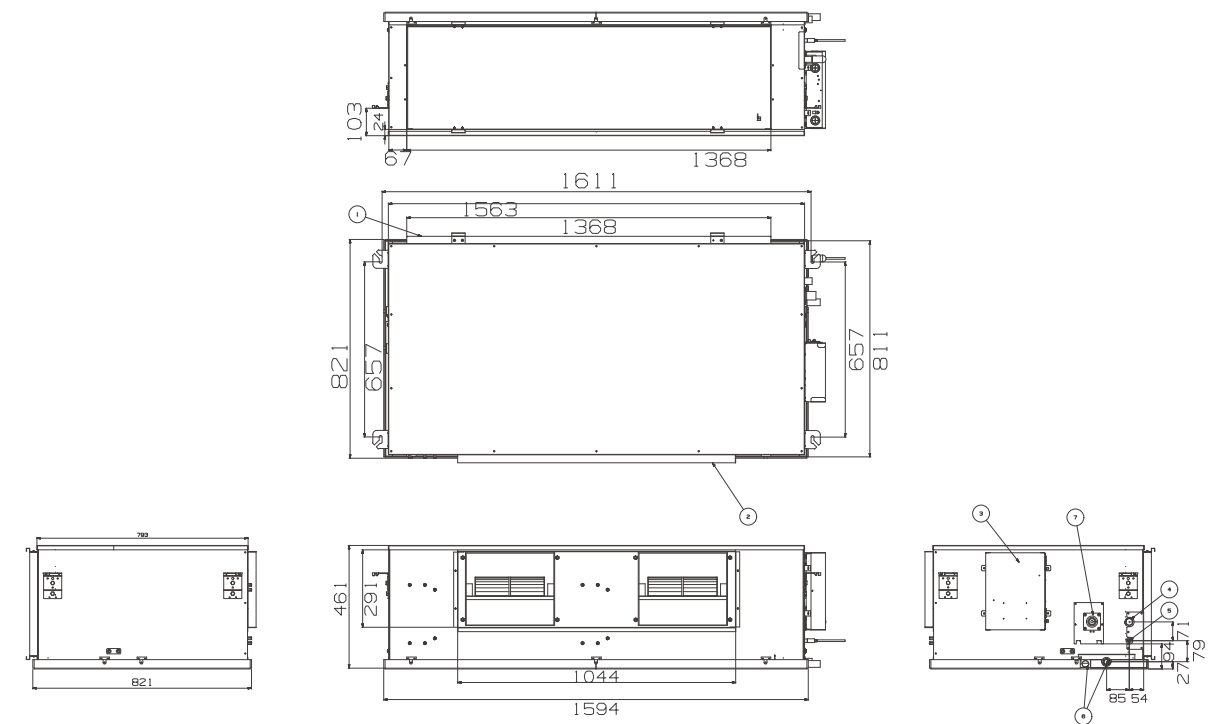

# CEILING SUSPENDED UNIT

H-INVERTER (R32)

## UV18FH.N10

(Unit : mm)

Part Name	Part Name
1	Air Intake
2	Air Outlet
3	Remote Controller Signal Receiver
4	Drain hose routing hole
5	Refrigerant pipe and routing hole
6	Gas pipe connection
7	Liquid pipe connection

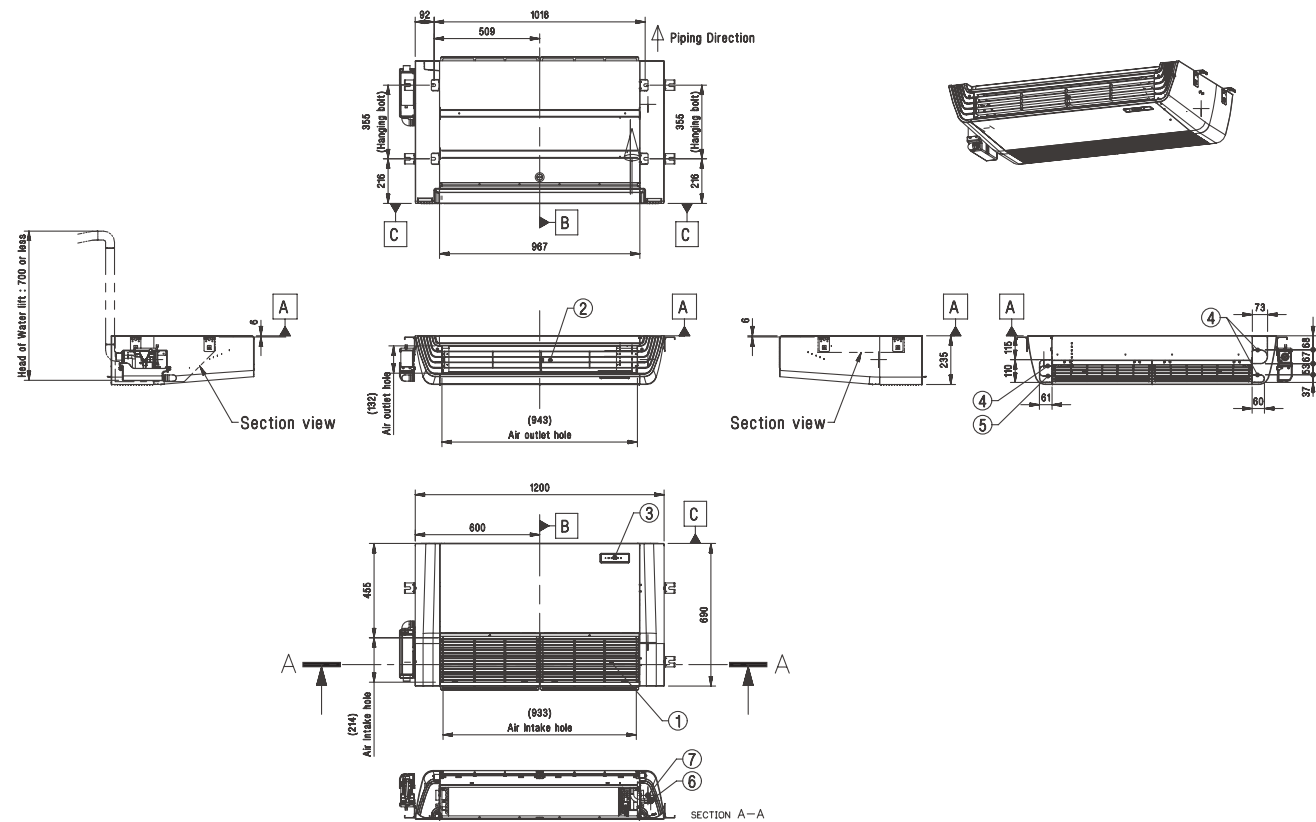

# CEILING SUSPENDED UNIT

H-INVERTER (R32)

## UV24FH.N20 / UV30FH.N20 / UV36FH.N20 / UV42FH.N20

(Unit : mm)

Part Name	Part Name
1	Air Intake
2	Air Outlet
3	Remote Controller Signal Receiver
4	Drain hose routing hole
5	Refrigerant pipe and routing hole
6	Gas pipe connection
7	Liquid pipe connection

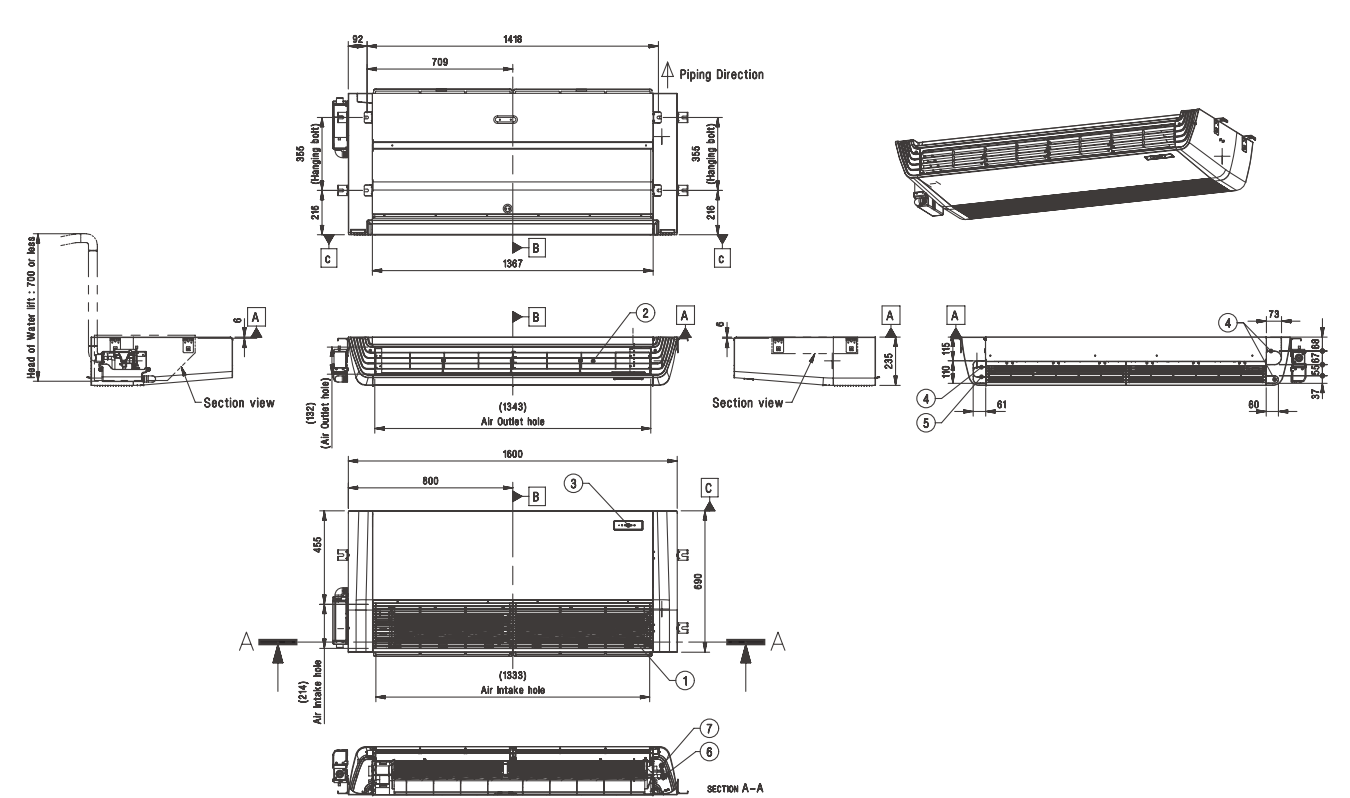

# CEILING SUSPENDED UNIT

STANDARD / COMPACT INVERTER (R32)

## UV18F.N10 / UV24F.N10 / UV30F.N10

(Unit : mm)

Part Name	Part Name
1	Air Intake
2	Air outlet
3	Remote Controller Signal Receiver
4	Drain hose routing hole
5	Refrigerant pipe and cable routing hole
6	Gas pipe connection
7	Liquid pipe connection

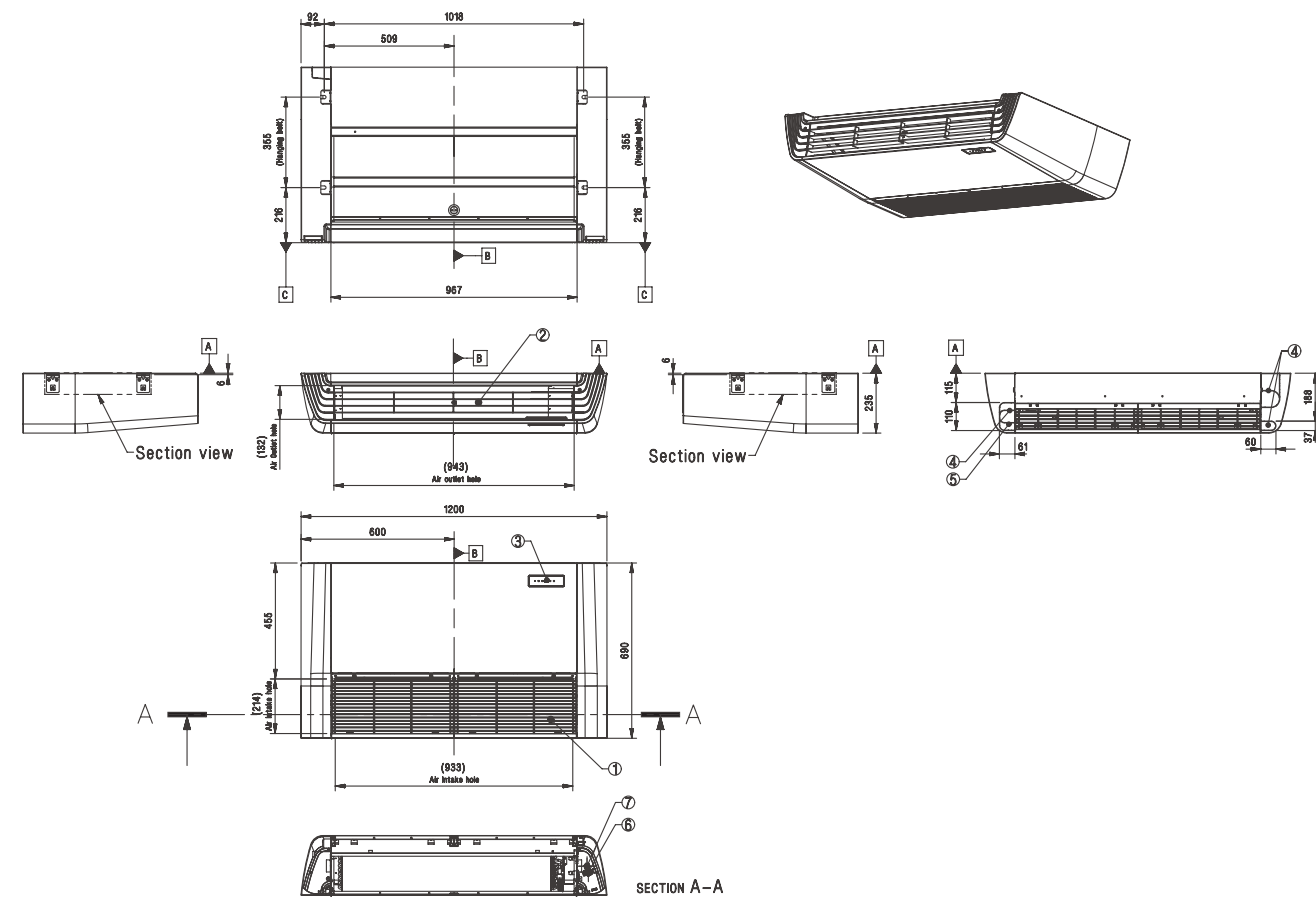

# CEILING SUSPENDED UNIT

STANDARD INVERTER (R32)

## UV36F.N20 / UV42F.N20 / UV48F.N20 / UV60F.N20

(Unit : mm)

Part Name	Part Name
1	Air Intake
2	Air outlet
3	Remote Controller Signal Receiver
4	Drain hose routing hole
5	Refrigerant pipe and cable routing hole
6	Gas pipe connection
7	Liquid pipe connection

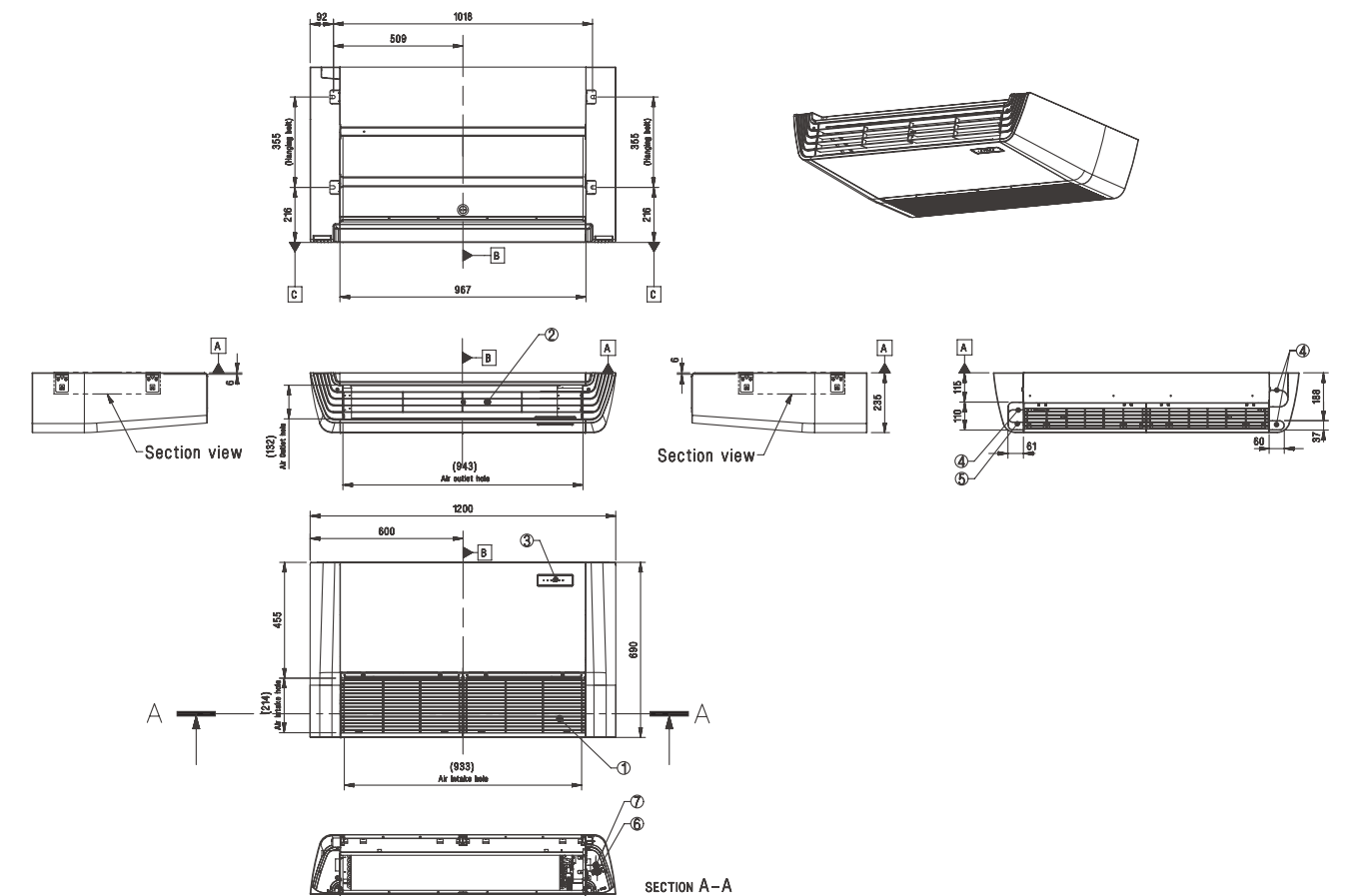



# CONSOLE

STANDARD INVERTER (R32)

UQ09.NA0 / UQ12.NA0 / UQ18.NA0

(Unit : mm)

Part Name
1 Air Suction Grille
2 Remote Controller Signal Reciver
3 Air Discharge Grille
4 Gas Pipe Connection
5 Liquid Pipe Connection
6 Drain Hose Connection
7 Refrigerant / Drain Pipe & Cable Routing Hole
8 Installation Plate
9 Terminal Block for Power Supply & Communication

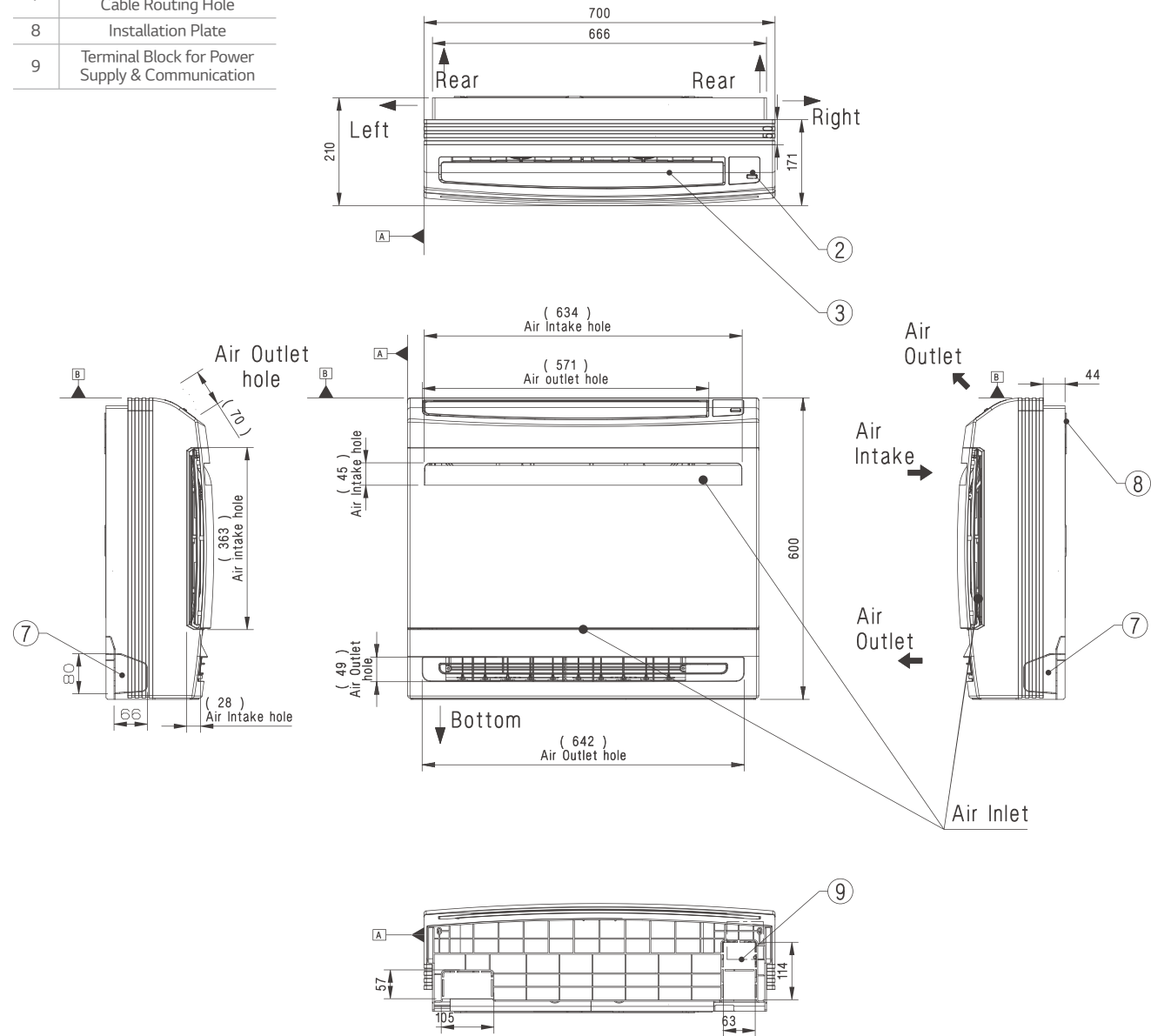

# WALL MOUNTED

STANDARD / COMPACT INVERTER (R32)

US30F.NR0 / US36F.NR0

(Unit : mm)

Part Name
1 Refrigerant / Drain Pipe and Cabel Routing Hole
2 Installation Plate
3 Drain Hose Connection
4 Terminal Block for Power Supply Communication
5 Display & Remote Controller Signal Receiver
6 Decoration Cover

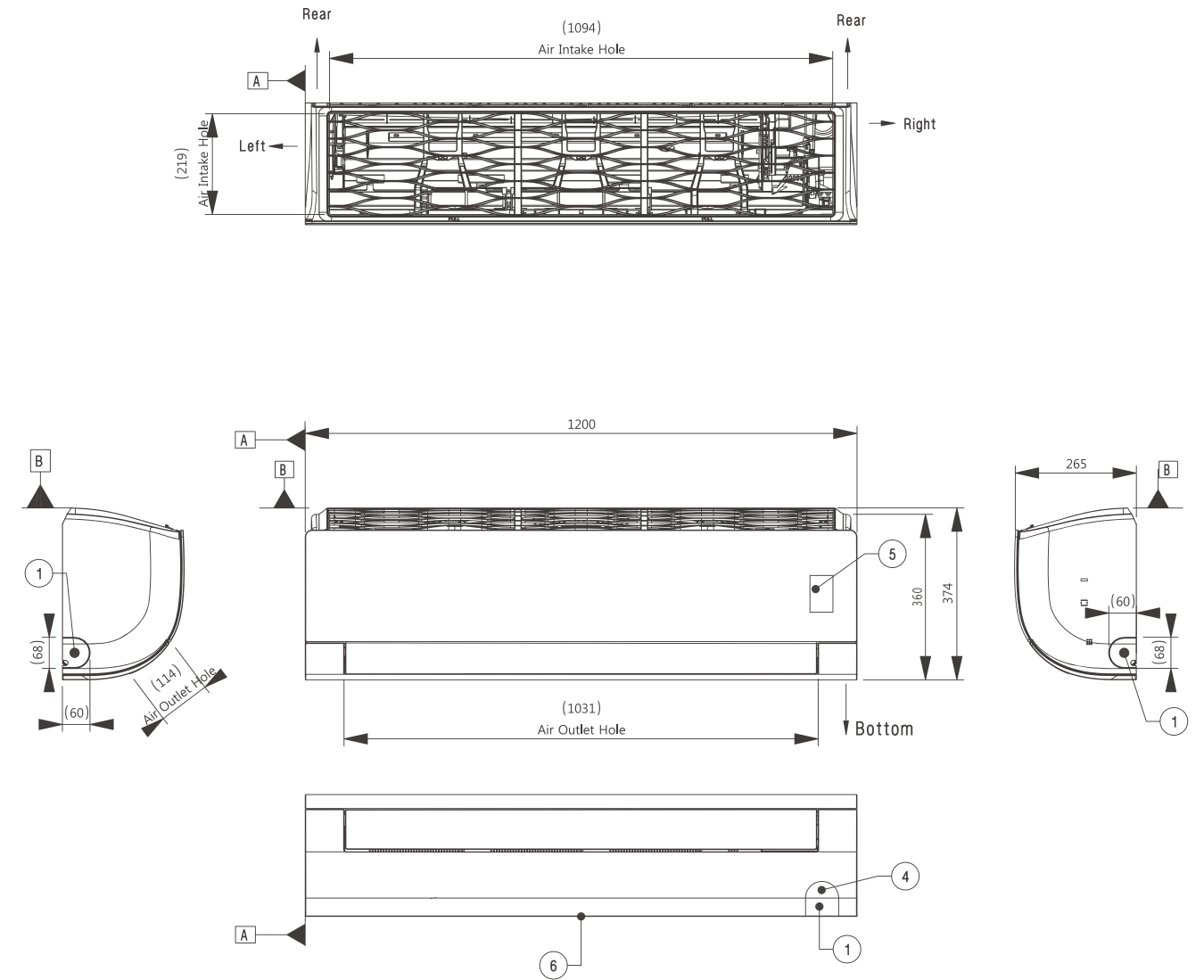

# FLOOR STANDING

STANDARD INVERTER (R410A)

## UP48.NT2

(Unit : mm)

	Part Name
1	Front air discharge grille
2	Display & Single receiver
3	Air suction grille

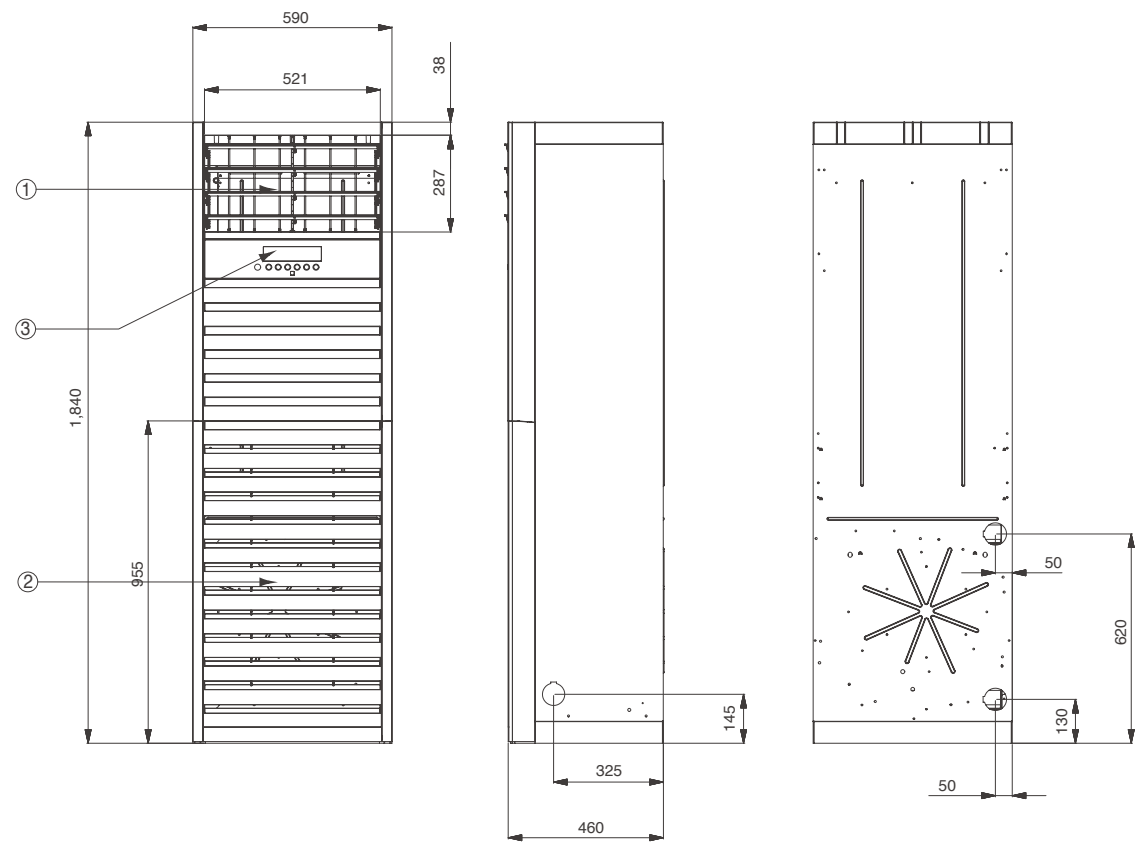

# UNIVERSAL OUTDOOR

HIGH / STANDARD / COMPACT INVERTER (R32)

## UUA1.ULO

(Unit : mm)

	Part Name
1	Air Outlet
2	Control cover & SVC valve cover
3	Power and communication cable connection
4	Gas pipe connection
5	Liquid pipe connection
6	Power and communication cable routing hole
7	Refrigerant pipe routing hole
8	Handle
9	Intake air temperature sensor cover

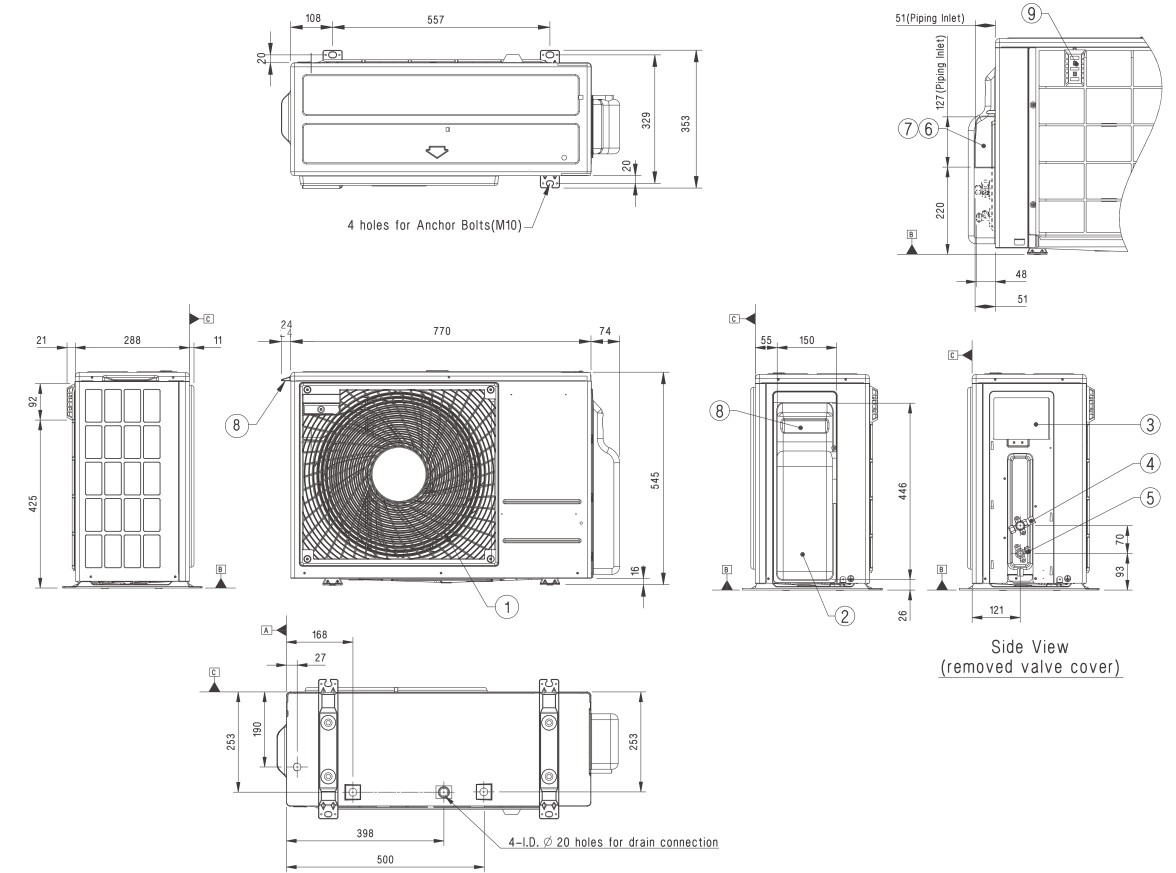
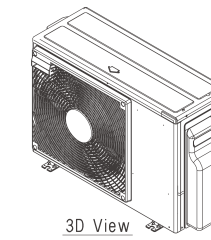

# UNIVERSAL OUTDOOR

HIGH / STANDARD / COMPACT INVERTER (R32)

## UUB1.U20

(Unit : mm)

Part Name
1 Air Outlet
2 Control cover & SVC valve cover
3 Power and communication cable connection
4 Gas pipe connection
5 Liquid pipe connection
6 Handle
7 Intake air temperature sensor cover

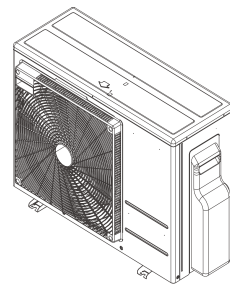

3D View

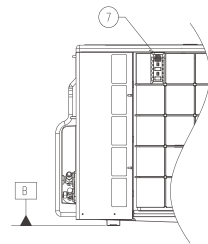
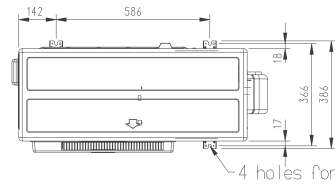

Side View  
(removed valve cover)

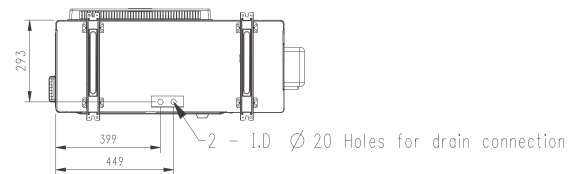
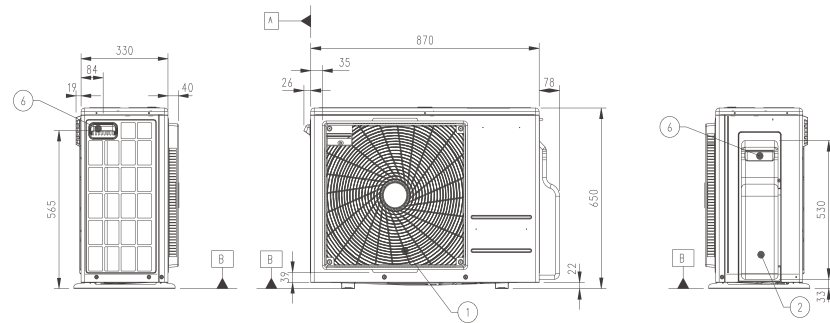

# UNIVERSAL OUTDOOR

HIGH / STANDARD / COMPACT INVERTER (R32)

## UUC1.U40

(Unit : mm)

Part Name
1 Air Outlet
2 Power and communication cable hole
3 Gas pipe connection
4 Liquid pipe connection
5 Handle
6 Pipe routing hole (Front)
7 Pipe routing hole (Side)
8 Pipe routing hole (Back)

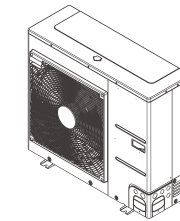

3D View

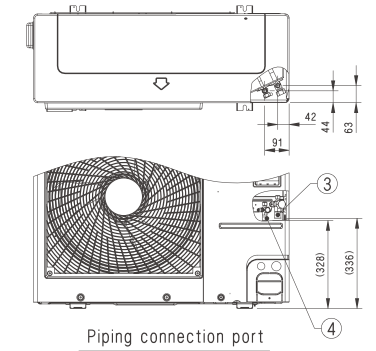
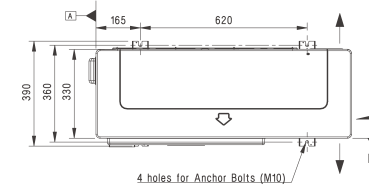

Piping connection port

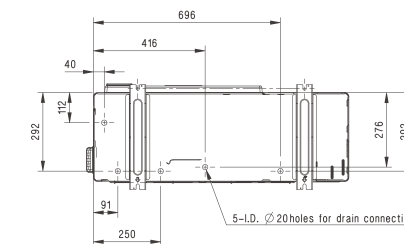
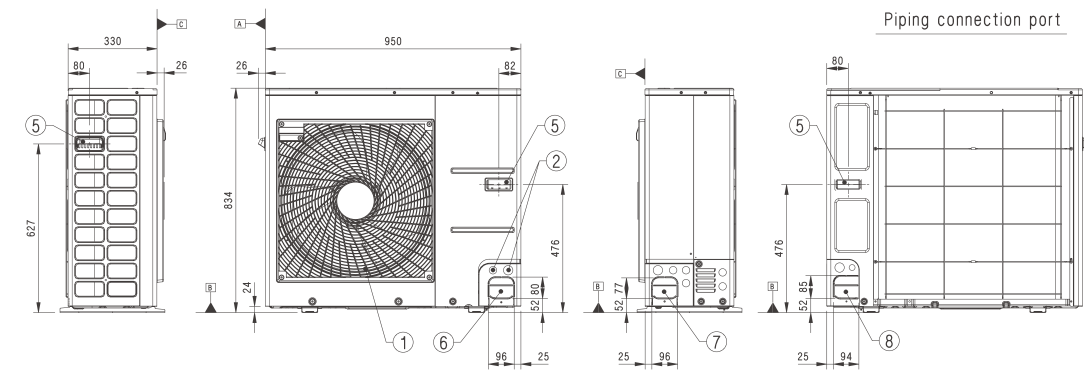

# UNIVERSAL OUTDOOR

STANDARD INVERTER (R32)

## UUD1.U30 / UUD3.U30

(Unit : mm)

Part Name
1 Air Outlet
2 Power and communication cable hole
3 Gas pipe connection
4 Liquid pipe connection
5 Handle
6 Pipe routing hole (Front)
7 Pipe routing hole (Side)
8 Pipe routing hole (Back)

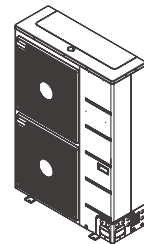

3D View

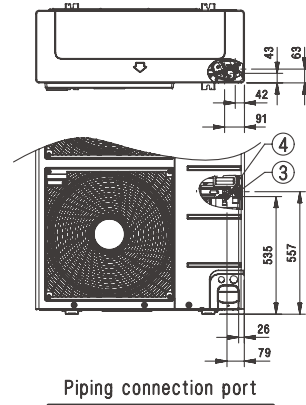
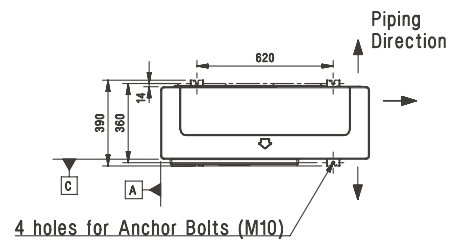

Piping connection port

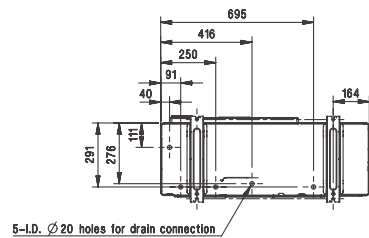
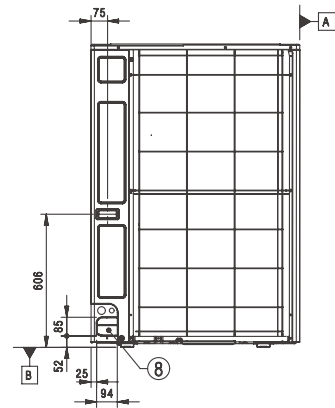
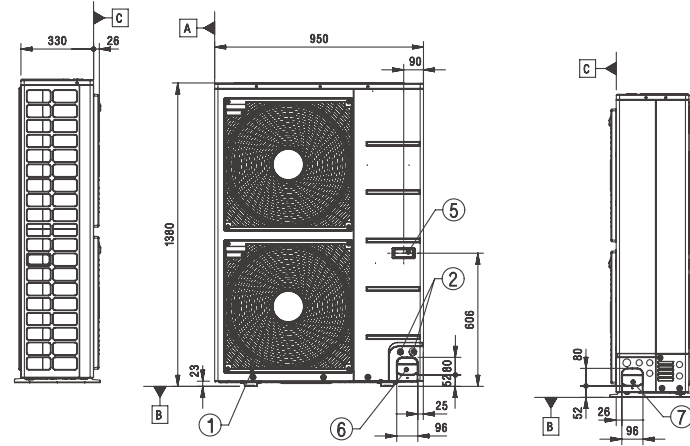

5-L.D. ∅20 holes for drain connection

# UNIVERSAL OUTDOOR

STANDARD INVERTER (R410A)

## UU48WR.U30 / UU49WR.U30

(Unit : mm)

Part Name
1 Air Outlet
2 Power and communication cable hole
3 Gas Pipe Connection
4 Liquid Pipe Connection
5 Handle
6 Pipe routing hole (front)
7 Pipe routing hole (side)
8 Pipe routing hole (back)

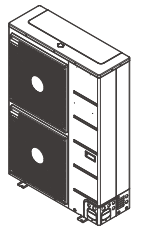
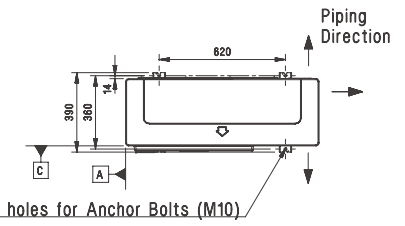

3D View

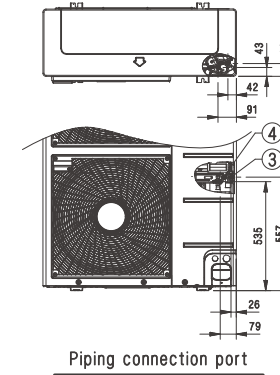

Piping connection port

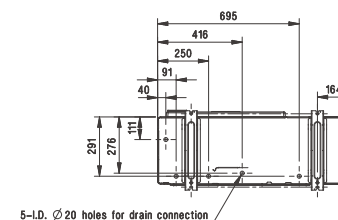
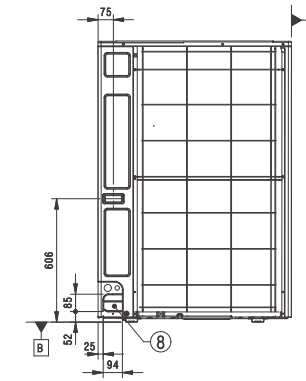
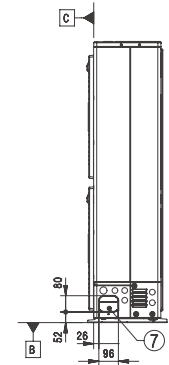
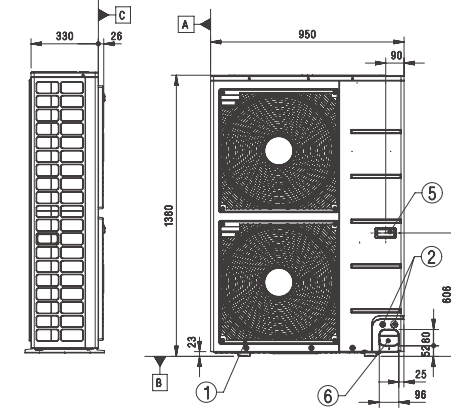

5-L.D. ∅20 holes for drain connection

# UNIVERSAL OUTDOOR

STANDARD INVERTER (R410A)

## UU70W.U34

(Unit : mm)

	Part Name
1	Air discharge grille
2	Gas pipe connection
3	Liquid pipe connection
4	Power & Transmission connection

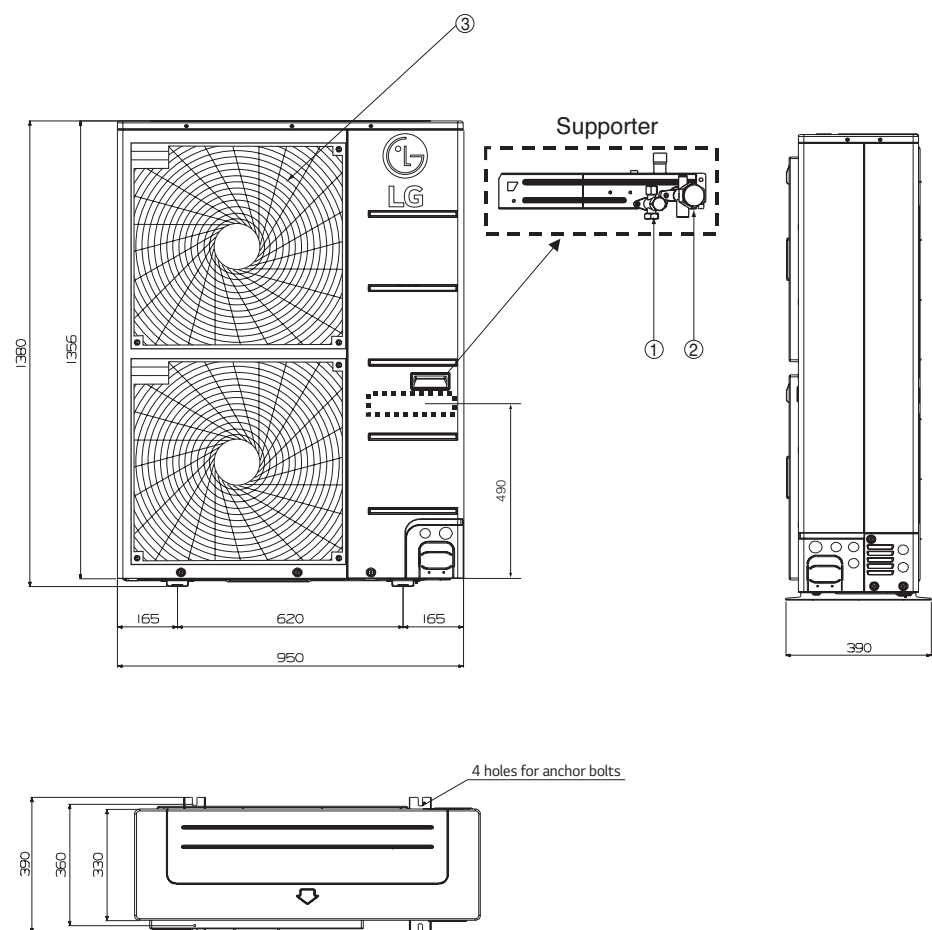

# UNIVERSAL OUTDOOR

STANDARD INVERTER (R410A)

## UU85W.U74

(Unit : mm)

	Part Name
1	Gas piping connection
2	Liquid piping connection
3	Air Inlet
4	Air Outlet
5	Drain Hole
6	Power and communication Cable Hole
7	Power and communication Cable Hole
8	Power and communication Cable Hole

