

Thank you for choosing a NIVELCO instrument.
We are sure that you will be satisfied throughout its use!



1. APPLICATION

The conductive measuring principle can be applied to liquids with specific conductivity over 10 µS/cm. The switching unit can sense the resistance between probes. Conductivity measurement is suitable only for detecting the presence of liquid at a given level of the tank. This level is represented by the length of the probe.

The level switch consists of a NIVOCONT KRK-622-□ type switching unit and the KLN-2□□ type probes selected according to the task. Probes are to be connected to the NIVOCONT KS□-□□□ type probe socket that can be screwed into the tank.

If the material of the tank or its internal insulation is not conductive then a reference probe should be used in addition to the one, two, three or four probe(s), if the material of the tank is conductive, the tank can be used as a reference probe.

The conductive switch is suitable for filling-emptying control with 2 relay outputs working simultaneously or for level detection of 2 independent levels (in 1 or 2 tanks) with 2 independent relay outputs. More level switches can also be used with one common reference probe "C" using any combination of multiple-probe and single-probe socket.

2. TECHNICAL DATA

2.1 GENERAL DATA

2.1.1 A JELFELDOLGOZÓ MŰSZAKI ADATAI

| Type | KRK-622-1, KRK-622-2 | KRK-622-4 |
|-----------------------------|---|------------|
| Probe voltage | max. 3.5 V AC | |
| Probe current | < 1 mA AC | |
| Sensitivity | Adjustable: 5 kΩ – 100 kΩ | |
| Max. cable capacity | 800 nF (sensitivity 5 kΩ) 100 nF (sensitivity 100 kΩ) | |
| Response time | max. 400 ms | |
| Setting accuracy (mech.) | ±5% | |
| ON / OFF switching delay | Adjustable: 0.5 – 10 s | |
| Relay output | 2x SPDT | |
| Switching voltage | 250 V AC1, 24 V DC | |
| Switching current | 16 A AC1 | |
| Switching power | 4000 VA AC1, 384 W DC | |
| Electrical strength | 4 kV (power – output) | |
| Mechanical life-span | 3 x 10 ⁷ switches | |
| Electrical life-span | 0.7 x 10 ⁵ switches | |
| Power supply U _n | 230 V or 110 V AC | 24 V AC/DC |
| | Galvanically separated (AC 50/60 Hz) | |
| Voltage range allowed | Nominal voltage -15% ... +10% | |
| Power consumption | 2.5 W / 5 VA (230 V AC, 110 V AC), 1.4 W / 2 VA (24 V AC/DC) | |
| Ambient temperature | -20 °C ... +55 °C (-4 °F to +131 °F) | |
| Electrical connection | max. 2.5 mm ² (AWG 14) | |
| Overvoltage category | II | |
| Pollution degree | 2 | |
| Electrical protection | class II | class III |
| Ingress protection | IP20 | |
| Mechanical connection | DIN EN 60715 rail | |
| Mass | 248 g | 147 g |

2.1.2 TECHNICAL DATA OF PROBE SOCKETS

| Type | KSK-201 | KSP-201 | KSS-201 | KSN-201 | KSH-202 | KSH-203 | KSH-204 | KLN-2□□ | KSH-301 | KSH-302 | KSH-303 | KSH-304 | |
|----------------------|-----------------------|------------------------------|-----------|-------------------------------|----------------------------------|---------|---------|---------|----------------------------------|--------------|---------|---------|--|
| Nr. of probes | 1 | | | | 2 + 1s* | 3 + 1s* | 4 + 1s* | 1 | 1 + 1s* | 2 + 1s* | 3 + 1s* | 4 + 1s* | |
| Insulation of socket | ABS | PP | PFA | | | | — | PP | — | | | | |
| Cable gland | Pg7 ⁽¹⁾ | M4 nut, rubber cap protected | | | M20x1.5 cable diameter 6 – 12 mm | | | — | M20x1.5 cable diameter 6 – 12 mm | | | | |
| Process connection | cable mounted | ¾" BSP | | | 1½" BSP | | | M6 | 1½" BSP | | | | |
| Socket material | — | PP | A44 steel | KO35 stainless steel (1.4571) | | | | — | PP | | | | |
| Housing material | ABS | — | | | Paint coated aluminium cast | | | — | BPT | | | | |
| Medium temperature | max. +80 °C (+176 °F) | | | | max. +200 °C (+392 °F) | | | | — | max. +80 °C | | | |
| Max. pressure | — | max. 0.3 MPa | | | max. 1.6 MPa | | | | — | max. 0.3 MPa | | | |
| Ingress protection | IP68 | | IP20 | | | IP65 | | | — | IP67 | | | |
| Mass | 0.05 kg | | 0.1 kg | | | 0.4 kg | | | 0.22 kg/m | | 0.2 kg | | |

s* = reference probe
(1) cable: Ø4 – 7 mm

2.2 ORDER CODES (NOT ALL CODE VARIATION AVAILABLE)

NIVOCONT KRK-622-□

| Power supply | Code |
|--------------|------|
| 230 V AC | 1 |
| 110 V AC | 2 |
| 24 V AC/DC | 4 |

| Type | Code |
|---|------|
| Cable probe | K |
| Single probe, PP socket | P |
| Single probe, steel socket | S |
| Single probe, stainless steel socket | N |
| Multiple probes, stainless steel socket | H |

NIVOCONT KS□-□□

| Type | Code |
|-------------------|------|
| Aluminium housing | 2 |
| Plastic housing | 3 |

| Probes | Code |
|-------------------------|------|
| 1 no | 1 |
| 2 nos + reference probe | 2 |
| 3 nos + reference probe | 3 |
| 4 nos + reference probe | 4 |

NIVOCONT KLN-2□□

| Probe length* | Code |
|---------------|---------|
| 0.5m ... 3m | 05...30 |

* to be ordered in 0.5 m units

NIVOCONT KLP-204 Probe separator (for KSH-200)

NIVOCONT KLP-201 Probe separator (for KSH-300 and KKH-200)

2.3 ACCESSORIES

2.3.1 ACCESSORIES OF THE DEVICE

- User's manual
- EU declaration of conformity
- Warranty Card

2.3.2 ACCESSORIES OF SEPARATELY PURCHASED PROBES

- Sealing (2 mm thick, KLINGER OILIT): 1 pc. ¾" (for KSP-201, KSS-201, KSN-201) and 1 pc. 1½" for a KSH-20□.
- M6 nut (standard SW): 3 pcs. for KSH-202, 4 pcs. for KSH-203, KSH-204.
- M6 nut non-st. SW: 1 pc. for KSH-204.

2.4 DIMENSIONS

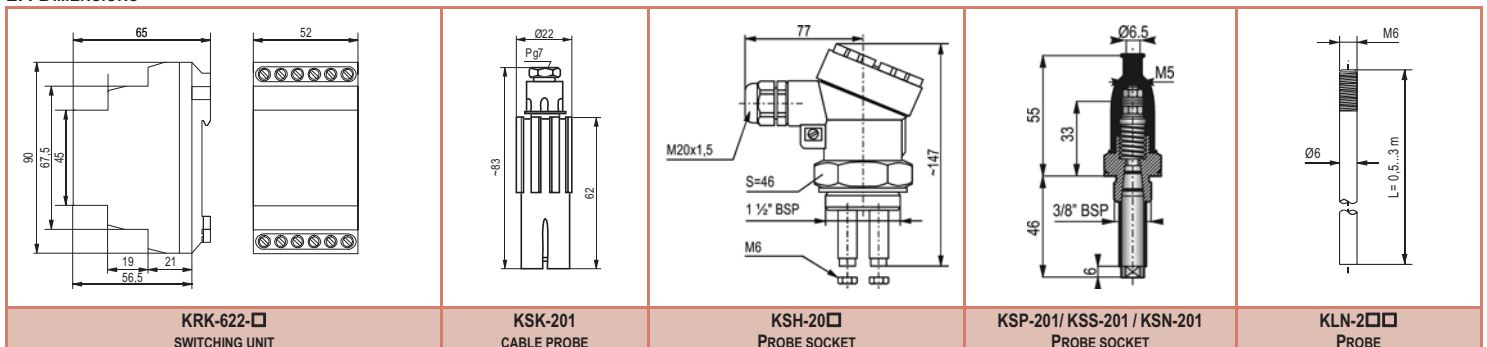

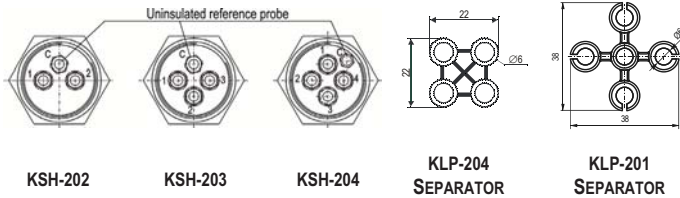

3. INSTALLATION

A **KRK-622-□** switching unit can be mounted on DIN EN 60715 rail.

It is recommended the **KLN-2□□** type probes to be cut to the length required for level detection on site. The probes should be screwed into the **KS□-□0□** type sockets.

ALWAYS REMEMBER TO TIGHTEN THE PROBE WITH AN M6 NUT!

When using **KSH-204** type probe sockets the reference probes should be tightened with special SW hexagonal M6 nuts!

It is suggested **KLP-201** or **KLP-204** type PVDF separators (suitable up to +130 °C) to be used at every 0.5 m for multiple probe devices to keep the probes apart.

A **KSK-201** single probe, attached to an insulated cable, can be lowered into pits and wells without running the risk of a short circuit. When a detection is needed in a well or in a plastic pipe 2 of them have to be used. For additional levels additional probes should be used.

4. ELECTRICAL CONNECTION

If the wall of the tank is conductive no reference probe is needed. In this case terminal "C" has to be connected to the tank.

On multiple probe units E1 and E2 are marked with 1 – 4, the reference probe is marked with "C". Admissible length of cable between switching unit and probes depends on cable capacitance and conductivity.

The terminal block assignment of KRK-622-1 and KRK-622-2 is not the same, the KRK-622-4 is different. There is no "S" terminal at the KRK-622-1 and KRK-622-2.

Referring to the illustration below for the terminal block assignments of the devices.

KRK-622-1, KRK-622-2

KRK-622-4

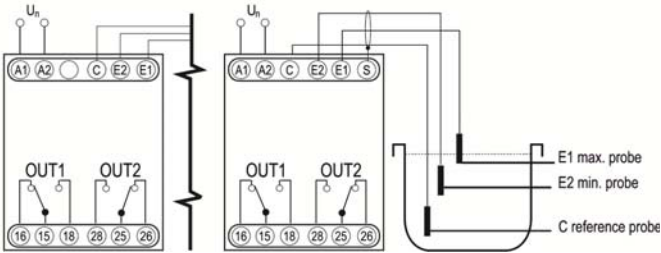

A1, A2 – power supply

C – reference probe

E1 – max. probe (OUT1)

E2 – min. probe (OUT2)

S – shielding

15, 16, 18 – 1. relay output – pump control 1

25, 26, 28 – 2. relay output – pump control 2

(function 1, 2, 3, 4) or alarm (function 5, 6, 7, 8)

To eliminate signal interferences it is recommended to use shielded cables to the probes.

5. PUTTING INTO OPERATION

5.1 SETTING

The green LED (Un) shows that the unit is on, the energised state of the relays are indicated by the OUT1 respectively OUT2 LEDs. If the OUT1, OUT2 (red) LEDs are flashing, they indicate the timer operation. When they light up, it shows that the corresponding relay is switched on. Yellow LED (FAIL) indicates probe failure (for example at Functions 5 and 6 probe E1 is flooded and probe E2 is not, which is unreal state so the yellow LED is on.)

Operating modes, delay ON and delay OFF can be set with the DIP switch on the front panel. $t_1[s]$ and $t_2[s]$ potentiometers are for adjusting the delay time. The delay value can change from 0.5 seconds to 10 seconds. You can set the sensitivity of the two probes independently using the R_{E1} or R_{E2} potentiometers. The sensitivity setting should comply with the conductivity of the fluid. Do not set sensitivity higher than required because the vapour precipitation may lead to operation disturbance. In heavily humid environment insulated probes can be used. With the ON Delay / OFF Delay switch on the DIP switch, delay type of the relays can be selected (switch-on delay or switch-off delay).

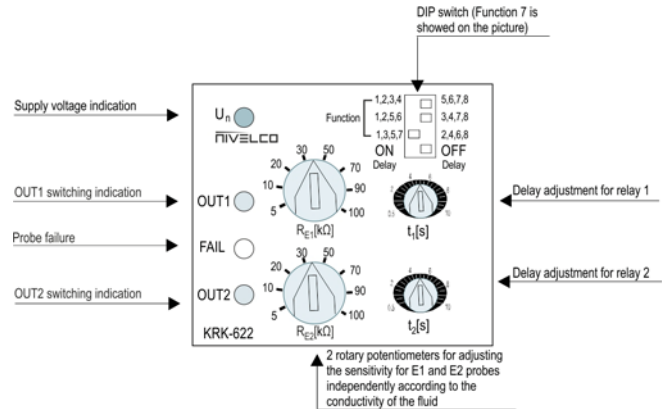

Front panel of NIVOCONT KRK-622

Example of setting DIP switch:

Select the desired function in accordance with the figures. The upper 3 switches are for selecting the number of the function you want to use. If you want to use Function 5 you should set the switches as follows: set the 1st switch to the right, the 2nd to the left and the 3rd to the left. Then select whether you need ON delay or OFF delay with the 4th switch. You can choose the type of delay, but you cannot deactivate the delay. However, the minimum delay time you can set with the potentiometers is 0.5 seconds. The DIP switch looks like this after setting function 5 with an OFF delay:

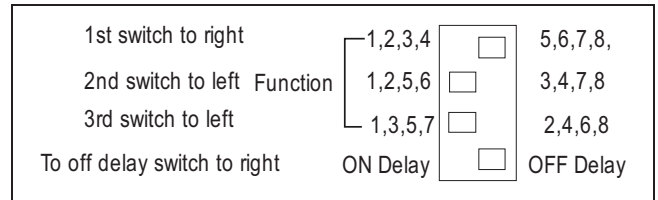

5.2 FUNCTIONS

Attention! The following wiring diagrams show the wiring of the KRK-622-4, 24V supply voltage device.

Functions 1 to 4 are for controlling 2 pumps according to the following picture:

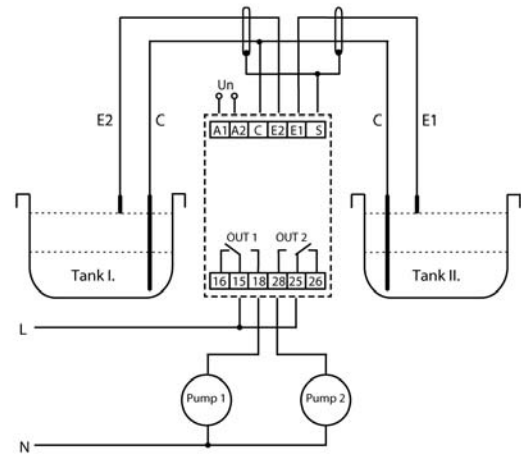

Functions 5 and 6 are for controlling one pump (filling or emptying one tank) and for generating alarm signal according to the following picture. If level is not between E1 and E2 alarm is generated:

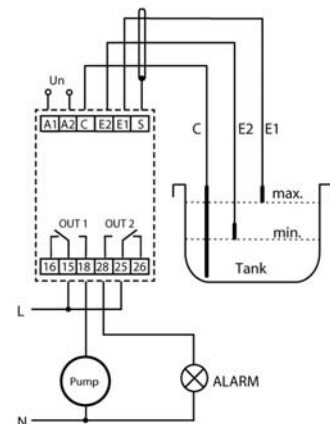

Functions 7 and 8 also controls one pump and generates one alarm signal:

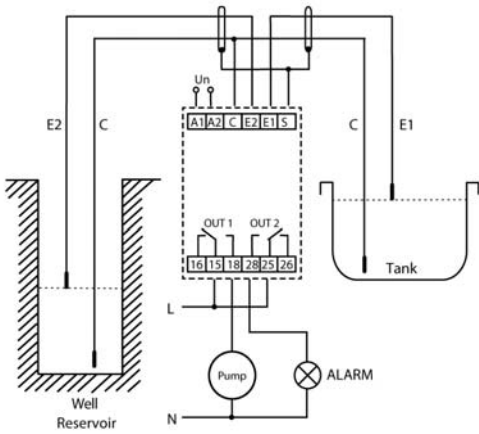

FUNCTION 1:
Controlling level in 2 separate tanks (each with 1 probe) - filling. The pumps are running and fill the tanks until the levels reach the corresponding probes (E1 or E2).
Relay 1 (E1): Pump control 1
Relay 2 (E2): Pump control 2

FUNCTION 2:
Controlling level in 2 separate tanks (each with 1 probe) - emptying. The pumps are running and emptying the tanks until probes are flooded.
Relay 1 (E1): Pump control 1
Relay 2 (E2): Pump control 2

FUNCTION 3:
Controlling level in 2 separate tanks (each with 1 probe). Pump 1 is emptying the tank and stops when probe E1 is not flooded anymore. Pump 2 is filling the tank and stops if level reaches probe E2.
Relay 1 (E1): Pump control 1
Relay 2 (E2): Pump control 2

FUNCTION 4:
Controlling level in 2 separate tanks (each with 1 probe). Pump 2 is emptying the tank and stops when probe E2 is not flooded anymore. Pump 1 is filling the tank and stops if level reaches probe E1.
Relay 1 (E1): Pump control 1
Relay 2 (E2): Pump control 2

FUNCTION 5:
Both probes and reference probe are in one tank. Relay 1 controls the pump, which keeps the tank filled and maintains the level between probes E1 and E2. Relay 2 is used to alarm signalling. Relay 2 is on if the level is not between the two probes.
Relay 1 (E1): Pump control 1
Relay 2 (E2): Alarm

FUNCTION 6:
Both probes and reference probe are in one tank. Relay 1 controls the pump, which keeps the tank empty and maintains the level between probes E1 and E2. Relay 2 is used to alarm signalling. Relay 2 is on if the level is not between the two probes.
Relay 1 (E1): Pump control 1
Relay 2 (E2): Alarm

FUNCTION 7:
Pumping from well to the tank – probe E2 is in the well, probe E1 is in the tank. The pump only runs if probe E2 is flooded (enough water in the well) and the tank is not full meaning the level does not reach probe E1. The alarm reports a lack of water in the well (probe E2 is not flooded).
Relay 1 (E1): Pump control 1
Relay 2 (E2): Alarm

FUNCTION 8:
Pumping from reservoir to the tank - probe E2 is in the reservoir, probe E1 is in the tank. The pump only runs if probe E2 is flooded (full reservoir) and the tank is not full (probe E1). The alarm reports the status of full tank and reservoir (both probes are flooded).
Relay 1 (E1): Pump control 1
Relay 2 (E2): Alarm

5.3 TIME DIAGRAMS

FUNCTION 1, 3, 4 – PUMP UP (FILLING), ON DELAY:



FUNCTION 1, 3, 4 – PUMP UP (FILLING), OFF DELAY:

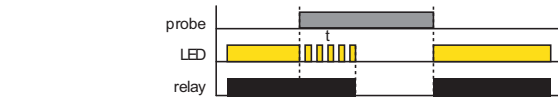

FUNCTION 2, 3, 4 – PUMP DOWN (EMPTYING), ON DELAY:

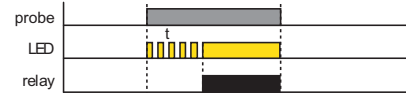

FUNCTION 2, 3, 4 – PUMP DOWN (EMPTYING), OFF DELAY:



FUNCTION 5 – PUMP UP (FILLING), ON DELAY:

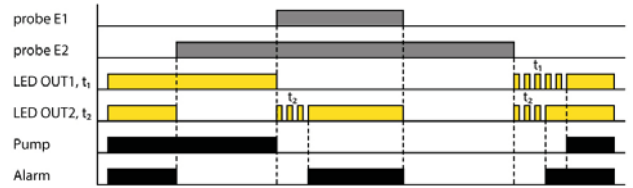

FUNCTION 5 – PUMP UP (FILLING), OFF DELAY:

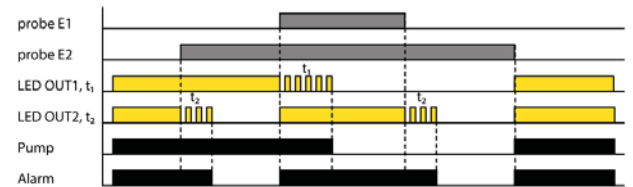

FUNCTION 6 – PUMP DOWN (EMPTYING THE TANK), ON DELAY:

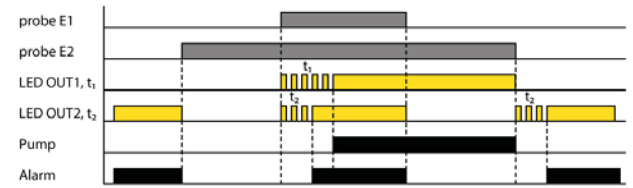

FUNCTION 6 – PUMP DOWN (EMPTYING THE TANK), OFF DELAY:

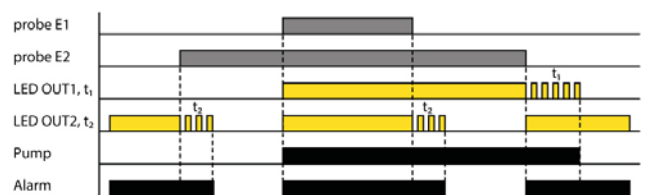

FUNCTION 7 – PUMP FROM WELL TO TANK, ON DELAY:

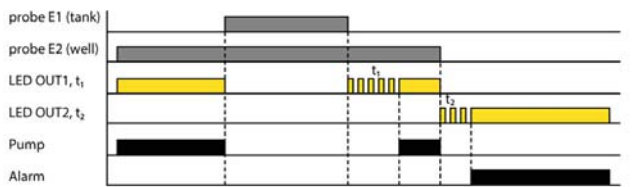

FUNCTION 7 – PUMP FROM WELL TO TANK, OFF DELAY:

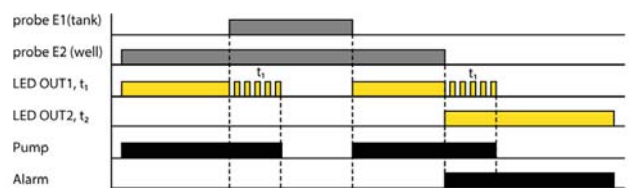

FUNCTION 8 – PUMP FROM RESERVOIRS TO TANK, ON DELAY:

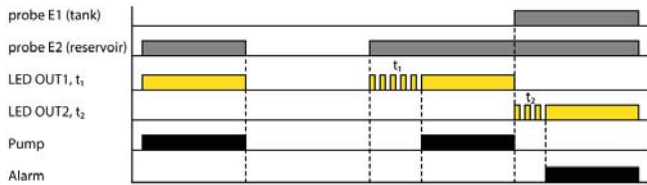

FUNCTION 8 – PUMP FROM RESERVOIRS TO TANK, OFF DELAY:

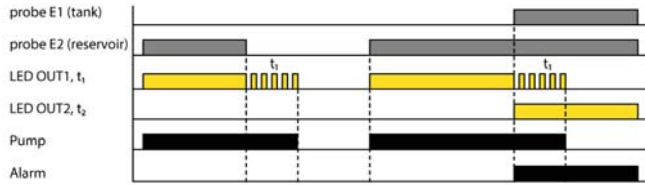

6. MAINTENANCE AND REPAIR

The device does not require regular maintenance. Repair within and beyond the warranty period is carried out at the manufacturer's premises only.

7. STORAGE CONDITIONS

Storage temperature: -30 °C ... +70 °C. (-22 °F ... +158 °F)

Relative humidity: max. 85%.

krk6221a0600h_05

December 2019

NIVELCO reserves the right to change technical data without notice.

Dodávateľ:

MICROWELL spol. s r. o.

SNP 2018/42, 927 00 Šafa

Tel.: (+421) 31/ 770 7585, 770 7587

E-mail: microwell@microwell.sk

<http://www.microwell.sk>